

## 250V N-Channel MOSFET KQB6N25

### ■ Features

- 5.5A, 500 V.  $R_{DS(ON)} = 1 \Omega$  @  $V_{GS} = 10 \text{ V}$
- Low gate charge (typical 6.6nC)
- Low  $C_{rss}$ (typical 7.5pF)
- Fast switching
- 100% avalanche tested
- Improved dv/dt capability

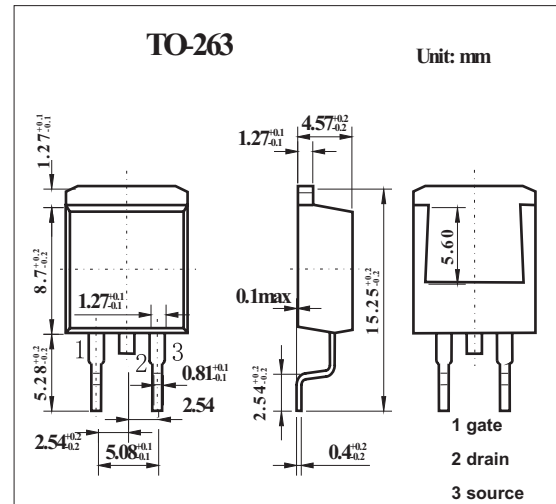
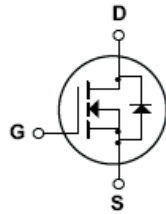

### ■ Absolute Maximum Ratings $T_a = 25^\circ\text{C}$

Parameter	Symbol	Rating	Unit
Drain to Source Voltage	$V_{DSS}$	250	V
Drain Current Continuous ( $T_c=25^\circ\text{C}$ )	$I_D$	5.5	A
Drain Current Continuous ( $T_c=100^\circ\text{C}$ )		3.5	A
Drain Current Pulsed *1	$I_{DM}$	22	A
Gate-Source Voltage	$V_{GSS}$	$\pm 30$	V
Single Pulsed Avalanche Energy*2	EAS	75	mJ
Avalanche Current *1	$I_{AR}$	5.5	A
Repetitive Avalanche Energy *1	EAR	6.3	mJ
Peak Diode Recovery dv/dt *3	dv/dt	5.5	V/ns
Power dissipation @ $T_A=25^\circ\text{C}$	$P_D$	3.13	W
Power dissipation @ $T_c=25^\circ\text{C}$	$P_D$	63	W
Derate above $25^\circ\text{C}$		0.5	W/ $^\circ\text{C}$
Operating and Storage Temperature	$T_J, T_{STG}$	-55 to 150	$^\circ\text{C}$
Maximum lead temperature for soldering purposes, 1/8" from case for 5 seconds	$T_L$	300	$^\circ\text{C}$
Thermal Resistance Junction to Case	$R_{\theta JC}$	1.98	$^\circ\text{C}/\text{W}$
Thermal Resistance Junction to Ambient *4	$R_{\theta JA}$	40	$^\circ\text{C}/\text{W}$
Thermal Resistance Junction to Ambient	$R_{\theta JA}$	62.5	$^\circ\text{C}/\text{W}$

\*1 Repetitive Rating:Pulse width limited by maximum junction temperature

\*2  $I = 4.0 \text{ mA}$ ,  $I_{AS} = 5.5 \text{ A}$ ,  $V_{DD} = 50 \text{ V}$ ,  $R_G = 25 \Omega$ , Startion  $T_J = 25^\circ\text{C}$

\*3  $I_{SD} \leq 5.5 \text{ A}$ ,  $d_i/d_t \leq 300 \text{ A}/\mu\text{S}$ ,  $V_{DD} \leq B_{VDS}$ , Startiong  $T_J = 25^\circ\text{C}$

\*4 When mounted on the minimum pad size recommended (PCB Mount)

## KQB6N25

## ■ Electrical Characteristics Ta = 25°C

Parameter	Symbol	Testconditions	Min	Typ	Max	Unit
Drain-Source Breakdown Voltage	B <sub>VDS</sub>	V <sub>GS</sub> = 0 V, I <sub>D</sub> = 250 μ A	250			V
Breakdown Voltage Temperature Coefficient	$\frac{\Delta B_{VDS}}{\Delta T_J}$	I <sub>D</sub> = 250 μ A, Referenced to 25°C		0.19		mV/°C
Zero Gate Voltage Drain Current	I <sub>DSS</sub>	V <sub>DS</sub> = 250 V, V <sub>GS</sub> = 0 V			1	μ A
		V <sub>DS</sub> = 200 V, T <sub>C</sub> = 125°C			10	μ A
Gate-Body Leakage Current, Forward	I <sub>GSSF</sub>	V <sub>GS</sub> = 30 V, V <sub>DS</sub> = 0 V			100	nA
Gate-Body Leakage Current, Reverse	I <sub>GSSR</sub>	V <sub>GS</sub> = -30 V, V <sub>DS</sub> = 0 V			-100	nA
Gate Threshold Voltage	V <sub>GS(th)</sub>	V <sub>DS</sub> = V <sub>GS</sub> , I <sub>D</sub> = 250 μ A	3.0		5.0	V
Static Drain-Source On-Resistance	R <sub>DS(on)</sub>	V <sub>GS</sub> = 10 V, I <sub>D</sub> = 2.75A		0.82	1.0	Ω
Forward Transconductance	g <sub>FS</sub>	V <sub>DS</sub> = 50 V, I <sub>D</sub> = 2.75A *		2.6		S
Input Capacitance	C <sub>iss</sub>	V <sub>DS</sub> = 25 V, V <sub>GS</sub> = 0 V, f = 1.0 MHz		230	300	pF
Output Capacitance	C <sub>oss</sub>			50	65	pF
Reverse Transfer Capacitance	C <sub>rss</sub>			7.5	10	pF
Turn-On Delay Time	t <sub>d(on)</sub>	V <sub>DD</sub> = 125 V, I <sub>D</sub> = 5.5A, R <sub>G</sub> = 25 Ω *		8	25	ns
Turn-On Rise Time	t <sub>r</sub>			65	140	ns
Turn-Off Delay Time	t <sub>d(off)</sub>			7.5	25	ns
Turn-Off Fall Time	t <sub>f</sub>			30	70	ns
Total Gate Charge	Q <sub>g</sub>	V <sub>DS</sub> = 200 V, I <sub>D</sub> = 5.5A, V <sub>GS</sub> = 10 V *		6.6	8.5	nC
Gate-Source Charge	Q <sub>gs</sub>			1.74		nC
Gate-Drain Charge	Q <sub>gd</sub>			3.4		nC
Maximum Continuous Drain-Source Diode Forward Current	I <sub>S</sub>				5.5	A
Maximum Pulsed Drain-Source Diode Forward Current	I <sub>SM</sub>				22	A
Drain-Source Diode Forward Voltage	V <sub>SD</sub>	V <sub>GS</sub> = 0 V, I <sub>S</sub> = 5.5 A			1.5	V
Diode Reverse Recovery Time	t <sub>rr</sub>	V <sub>GS</sub> = 0 V, dI <sub>F</sub> /dt = 100 A/μ s, I <sub>S</sub> = 5.5A *		125		ns
Diode Reverse Recovery Current	Q <sub>rr</sub>				0.5	

\* Pulse Test: Pulse Width ≤ 300 μ s, Duty Cycle ≤ 2.0%