

300V N-Channel MOSFET KQB3N30

■ Features

- 3.2A, 300 V. $R_{DS(ON)} = 2.2\ \Omega$ @ $V_{GS} = 10\ V$
- Low gate charge (typical 5.5nC)
- Low C_{rss} (typical 6.0pF)
- Fast switching
- 100% avalanche tested
- Improved dv/dt capability

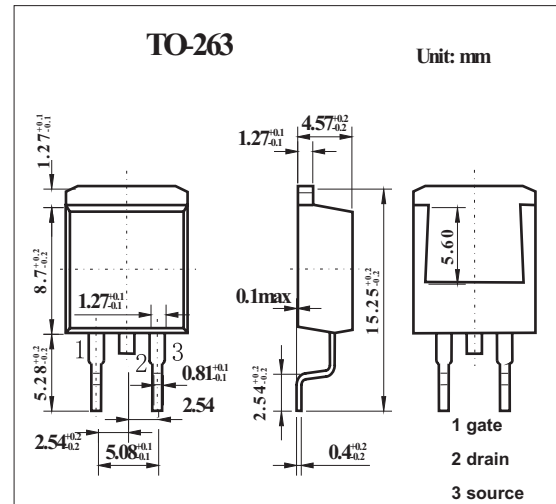
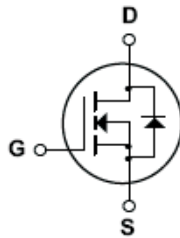

■ Absolute Maximum Ratings $T_a = 25^\circ\text{C}$

Parameter	Symbol	Rating	Unit
Drain to Source Voltage	V_{DSS}	300	V
Drain Current Continuous ($T_c=25^\circ\text{C}$)	I_D	3.2	A
Drain Current Continuous ($T_c=100^\circ\text{C}$)		2.02	A
Drain Current Pulsed *1	I_{DM}	12.8	A
Gate-Source Voltage	V_{GSS}	± 30	V
Single Pulsed Avalanche Energy*2	E_{AS}	140	mJ
Avalanche Current *1	I_{AR}	3.2	A
Repetitive Avalanche Energy *1	E_{AR}	5.5	mJ
Peak Diode Recovery dv/dt *3	dv/dt	4.5	V/ns
Power dissipation @ $T_A=25^\circ\text{C}$	P_D	3.13	W
Power dissipation @ $T_c=25^\circ\text{C}$ Derate above 25°C		0.44	W/ $^\circ\text{C}$
Operating and Storage Temperature	T_J, T_{STG}	-55 to 150	$^\circ\text{C}$
Maximum lead temperature for soldering purposes, 1/8" from case for 5 seconds	T_L	300	$^\circ\text{C}$
Thermal Resistance Junction to Case	$R_{\theta JC}$	2.27	$^\circ\text{C}/\text{W}$
Thermal Resistance Junction to Ambient *4	$R_{\theta JA}$	40	$^\circ\text{C}/\text{W}$
Thermal Resistance Junction to Ambient	$R_{\theta JA}$	62.5	$^\circ\text{C}/\text{W}$

*1 Repetitive Rating:Pulse width limited by maximum junction temperature

*2 $I = 22.5\text{mA}$, $I_{AS} = 3.2\text{A}$, $V_{DD} = 50\text{V}$, $R_G = 25\ \Omega$, Startion $T_J = 25^\circ\text{C}$

*3 $I_{SD} \leq 3.2\text{A}$, $di/dt \leq 200\text{A}/\mu\text{S}$, $V_{DD} \leq B_{VDSS}$, Startiong $T_J = 25^\circ\text{C}$

*4 When mounted on the minimum pad size recommended (PCB Mount)

KQB3N30

■ Electrical Characteristics Ta = 25°C

Parameter	Symbol	Testconditions	Min	Typ	Max	Unit
Drain-Source Breakdown Voltage	BV _{DSS}	V _{GS} = 0 V, I _D = 250 μA	300			V
Breakdown Voltage Temperature Coefficient	$\frac{\Delta BV_{DSS}}{\Delta T_J}$	I _D = 250 μA, Referenced to 25°C		0.35		mV/°C
Zero Gate Voltage Drain Current	I _{DSS}	V _{DS} = 300 V, V _{GS} = 0 V			1	μA
		V _{DS} = 240 V, T _C = 125°C			10	μA
Gate-Body Leakage Current, Forward	I _{GSSF}	V _{GS} = 30 V, V _{DS} = 0 V			100	nA
Gate-Body Leakage Current, Reverse	I _{GSSR}	V _{GS} = -30 V, V _{DS} = 0 V			-100	nA
Gate Threshold Voltage	V _{GS(th)}	V _{DS} = V _{GS} , I _D = 250 μA	3.0		5.0	V
Static Drain-Source On-Resistance	R _{DS(on)}	V _{GS} = 10 V, I _D = 1.6A		1.65	2.2	Ω
Forward Transconductance	g _{FS}	V _{DS} = 50 V, I _D = 1.6A *		1.75		S
Input Capacitance	C _{iss}	V _{DS} = 25 V, V _{GS} = 0 V, f = 1.0 MHz		175	230	pF
Output Capacitance	C _{oss}			40	50	pF
Reverse Transfer Capacitance	C _{rss}			6	8	pF
Turn-On Delay Time	t _{d(on)}	V _{DD} = 150 V, I _D = 3.2A, R _G = 25 Ω *		10	30	ns
Turn-On Rise Time	t _r			40	90	ns
Turn-Off Delay Time	t _{d(off)}			10	30	ns
Turn-Off Fall Time	t _f			25	60	ns
Total Gate Charge	Q _g	V _{DS} = 240 V, I _D = 3.2A, V _{GS} = 10 V *		5.5	7.0	nC
Gate-Source Charge	Q _{gs}			1.5		nC
Gate-Drain Charge	Q _{gd}			2.5		nC
Maximum Continuous Drain-Source Diode Forward Current	I _S				3.2	A
Maximum Pulsed Drain-Source Diode Forward Current	I _{SM}				12.8	A
Drain-Source Diode Forward Voltage	V _{SD}	V _{GS} = 0 V, I _S = 3.2 A			1.5	V
Diode Reverse Recovery Time	t _{rr}	V _{GS} = 0 V, diF/dt = 100 A/μs, I _S = 3.2A		120		ns
Diode Reverse Recovery Current	Q _{rr}				0.4	

* Pulse Test: Pulse Width ≤ 300 μs, Duty Cycle ≤ 2.0%