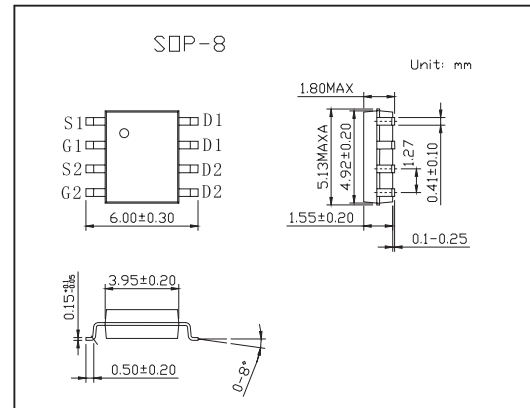
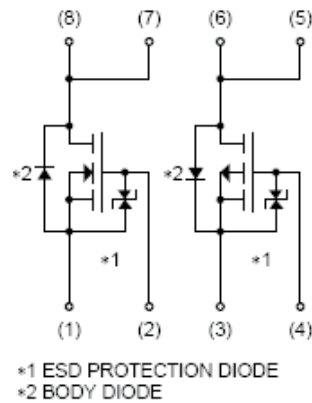

## Switching

## KP8M9

## ■ Features

- Low on-resistance.
- Built-in G-S Protection Diode.
- Small and Surface Mount Package.
- Power switching, DC / DC converter.

■ Absolute Maximum Ratings  $T_a = 25^\circ\text{C}$ 

Parameter	Symbol	N-Channel	P-Channel	Unit
Drain-source voltage	$V_{DS}$	30	-30	V
Gate-source voltage	$V_{GS}$	20	-20	V
Drain current Continuous	$I_D$	$\pm 9.0$	$\pm 5.0$	A
Drain current Pulsed *	$I_{DP}$	$\pm 36$	$\pm 20$	A
Source current (Body diode) Continuous	$I_S$	1.6	-1.6	A
Source current (Body diode) Pulsed *	$I_{SP}$	36	-20	A
Total power dissipation	$P_D$	2		W
Channel temperature	$T_{ch}$	150		$^\circ\text{C}$
Storage temperature	$T_{stg}$	-55 to +150		$^\circ\text{C}$
Channel to ambient	$R_{th(ch-a)}$	62.5		$^\circ\text{C/W}$

\*  $P_w \leq 10 \mu\text{s}$ , Duty cycle  $\leq 1\%$

## KP8M9

## ■ Electrical Characteristics Ta = 25°C

Parameter	Symbol	Testconditions	Min	Typ	Max	Unit
Gate-source leakage	I <sub>GSS</sub>	V <sub>GS</sub> =20V, V <sub>DS</sub> =0V			10	μ A
		V <sub>GS</sub> =-20V, V <sub>DS</sub> =0V			±10	
Drain-source breakdown voltage	V <sub>(BR) DSS</sub>	I <sub>D</sub> =1mA, V <sub>GS</sub> =0V	30			V
		I <sub>D</sub> =-1mA, V <sub>GS</sub> =0V	-30			
Zero gate voltage drain current	I <sub>DSS</sub>	V <sub>DS</sub> =30V, V <sub>GS</sub> =0V			1	μ A
		V <sub>DS</sub> =-30V, V <sub>GS</sub> =0V			-1	
Gate threshold voltage	V <sub>GS(th)</sub>	V <sub>DS</sub> =10V, I <sub>D</sub> =1mA	1.0		2.5	V
		V <sub>DS</sub> =-10V, I <sub>D</sub> =-1mA	-1.0		-2.5	
Static drain-source on-state resistance	R <sub>DS(on)</sub>	I <sub>D</sub> =9.0A, V <sub>GS</sub> =10A		12	18	m Ω
		I <sub>D</sub> =9.0A, V <sub>GS</sub> =4.5V		16	24	
		I <sub>D</sub> =9.0A, V <sub>GS</sub> =4V		17	25	
Static drain-source on-state resistance	R <sub>DS(on)</sub>	I <sub>D</sub> =-5.0A, V <sub>GS</sub> =-10A		30	42	m Ω
		I <sub>D</sub> =-2.5A, V <sub>GS</sub> =-4.5V		40	56	
		I <sub>D</sub> =-2.5A, V <sub>GS</sub> =-4.0V		45	63	
Forward transfer admittance	Y <sub>fs</sub>	I <sub>D</sub> =9.0A, V <sub>DS</sub> =10V	7.0			S
		I <sub>D</sub> =-2.5A, V <sub>DS</sub> =-10V	4.5			
Input capacitance	C <sub>iss</sub>	N-Channel V <sub>DS</sub> =10V, V <sub>GS</sub> =0V, f=1MHz	N-Ch		1190	pF
			P-Ch		1400	
Output capacitance	C <sub>oss</sub>	P-Channel	N-Ch		340	pF
			P-Ch		300	
Reverse transfer capacitance	C <sub>rss</sub>	V <sub>DS</sub> =-10V, V <sub>GS</sub> =0V, f=1MHz	N-Ch		190	pF
			P-Ch		230	
Turn-on delay time	t <sub>d(on)</sub>	I <sub>D</sub> =4.5A, V <sub>DD</sub> =15V	N-Ch		10	ns
		I <sub>D</sub> =-2.5A, V <sub>DD</sub> =-15V	P-Ch		15	
Rise time	t <sub>r</sub>	N-Channel V <sub>GS</sub> =10V, R <sub>L</sub> =3.33 Ω, R <sub>G</sub> =10 Ω	N-Ch		15	ns
			P-Ch		30	
Turn-off delay time	t <sub>d(off)</sub>	P-Channel V <sub>GS</sub> =-10V, R <sub>L</sub> =6.0 Ω, R <sub>G</sub> =10 Ω	N-Ch		55	ns
			P-Ch		80	
Fall time	t <sub>f</sub>	V <sub>GS</sub> =-10V, R <sub>L</sub> =6.0 Ω, R <sub>G</sub> =10 Ω	N-Ch		22	ns
			P-Ch		40	
Total gate charge	Q <sub>g</sub>	N-Channel V <sub>DD</sub> =15V, V <sub>GS</sub> =5V, I <sub>D</sub> =9.0A	N-Ch		15	nC
			P-Ch		16	
Gate-source charge	Q <sub>gs</sub>	P-Channel V <sub>DD</sub> =-15V, V <sub>GS</sub> =-5V, I <sub>D</sub> =-5.0A	N-Ch		3.0	nC
			P-Ch		3.5	
Gate-drain charge	Q <sub>gd</sub>	V <sub>DD</sub> =-15V, V <sub>GS</sub> =-5V, I <sub>D</sub> =-5.0A	N-Ch		6.1	nC
			P-Ch		6.5	
Forward voltage	V <sub>SD</sub>	I <sub>S</sub> =6.4A, V <sub>GS</sub> =0V	N-Ch		1.2	V
		I <sub>S</sub> =-1.6A, V <sub>GS</sub> =0V	P-Ch		-1.2	