

Dual N-Channel 2.5-V (G-S) MOSFET KI5904DC

■ Features

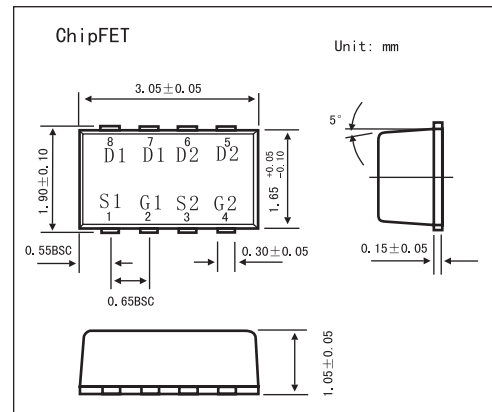
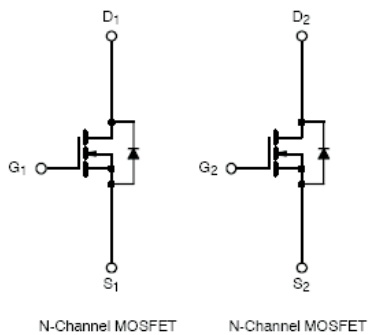

■ Absolute Maximum Ratings $T_a = 25^\circ\text{C}$

Parameter	Symbol	5secs	Steady State	Unit
Drain-Source Voltage	V_{DS}	20		V
Gate-Source Voltage	V_{GS}	± 12		
Continuous Drain Current ($T_J = 150^\circ\text{C}$) $T_A = 25^\circ\text{C}$ $T_A = 85^\circ\text{C}$	I_D	± 4.2	± 3.1	A
		± 3.0	± 2.2	
Pulsed Drain Current	I_{DM}	± 10		
Continuous Source Current (Diode Conduction)*	I_S	1.8	0.9	
Maximum Power Dissipation * $T_A = 25^\circ\text{C}$ $T_A = 85^\circ\text{C}$	P_D	2.1	1.1	W
		1.1	0.6	
Operating Junction and Storage Temperature Range	T_J, T_{stg}	-55 to 150		$^\circ\text{C}$
Soldering Recommendations		260		$^\circ\text{C}$

*Surface Mounted on 1" X 1" FR4 Board.

■ Thermal Resistance Ratings

Parameter	Symbol	Typical	Maximum	Unit	
Maximum Junction-to-Ambient *	R_{thJA}	$t \leq 5 \text{ sec}$	50	60	$^\circ\text{C}/\text{W}$
		Steady-State	90	110	
Maximum Junction-to-Foot (Drain)	R_{thJF}	30	40		

* Surface Mounted on 1" X 1" FR4 Board.

KI5904DC

■ Electrical Characteristics Ta = 25°C

Parameter	Symbol	Testconditions	Min	Typ	Max	Unit
Gate Threshold Voltage	$V_{GS(th)}$	$V_{DS} = V_{GS}, I_D = 250 \mu A$	0.6			V
Gate-Body Leakage	I_{GSS}	$V_{DS} = 0 V, V_{GS} = \pm 12 V$			± 100	nA
Zero Gate Voltage Drain Current	I_{DSS}	$V_{DS} = 16 V, V_{GS} = 0 V$			1	μA
		$V_{DS} = 16 V, V_{GS} = 0 V, T_J = 85^\circ C$			5	
On-State Drain Current*	$I_{D(on)}$	$V_{DS} \geq 5 V, V_{GS} = 4.5 V$	10			A
Drain Source On State Resistance*	$r_{DS(on)}$	$V_{GS} = 4.5 V, I_D = 3.1 A$		0.065	0.075	Ω
		$V_{GS} = 2.5 V, I_D = 2.3 A$		0.115	0.143	
Forward Transconductance	g_{fs}	$V_{DS} = 10 V, I_D = 3.1 A$		8		S
Schottky Diode Forward Voltage*	V_{SD}	$I_S = 0.9 A, V_{GS} = 0 V$		0.8	1.2	V
Total Gate Charge	Q_g	$V_{DS} = 10 V, V_{GS} = 4.5 V, I_D = 3.1 A$		4	7.5	nC
Gate-Source Charge	Q_{gs}			0.6		
Gate-Drain Charge	Q_{gd}			1.3		
Turn-On Delay Time	$t_{d(on)}$	$V_{DD}=10V, R_L=10 \Omega, I_D=1A, V_{GEN}=10V, R_G=6 \Omega$		12	18	ns
Rise Time	t_r			35	55	
Turn-Off Delay Time	$t_{d(off)}$			19	30	
Fall Time	t_f			9	15	
Source-Drain Reverse Recovery Time	t_{rr}	$I_F = 0.9 A, di/dt = 100 A/\mu s$		40	80	ns

* Pulse test :Pulse width $\leq 300 \mu s$, duty cycle $\leq 2\%$