

N-Channel 2.5-V (G-S) MOSFET

KI5404BDC

■ Features

- TrenchFET Power MOSFET

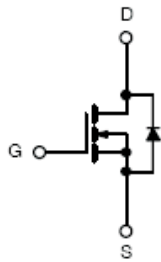

N-Channel MOSFET

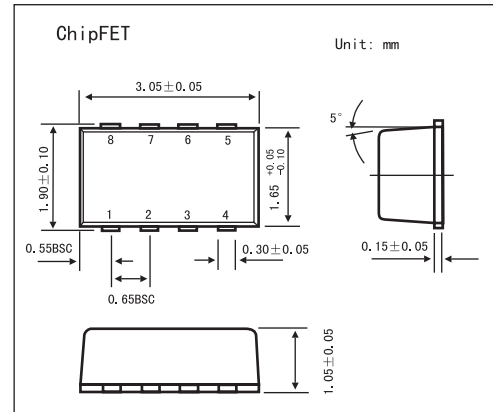

■ Absolute Maximum Ratings $T_a = 25^\circ\text{C}$

Parameter		Symbol	5 secs	Steady State	Unit
Drain-Source Voltage		V_{DS}	20		V
Gate-Source Voltage		V_{GS}	± 12		
Continuous Drain Current ($T_J = 150^\circ\text{C}$) *	$T_A = 25^\circ\text{C}$	I_D	7.5	5.4	A
	$T_A = 70^\circ\text{C}$		5.4	3.9	
Pulsed Drain Current		I_{DM}	20		
Continuous Source Current *		I_S	2.1	1.1	
Maximum Power Dissipation *	$T_A = 25^\circ\text{C}$	P_D	2.5	1.3	W
	$T_A = 70^\circ\text{C}$		1.3	0.7	
Operating Junction and Storage Temperature Range		T_J, T_{stg}	-55 to 150		$^\circ\text{C}$
Soldering Recommendations (Peak Temperature)			260		$^\circ\text{C}$
Parameter		Symbol	Typ	Max	Unit
Maximum Junction-to-Ambienta	$t \leq 5 \text{ sec}$	R_{thJA}	45	50	$^\circ\text{C/W}$
	Steady-State		80	95	
Maximum Junction-to-Foot (Drain)	Steady-State	R_{thJF}	18	22	

* Surface Mounted on 1" X 1' FR4 Board.

KI5404BDC

■ Electrical Characteristics Ta = 25°C

Parameter	Symbol	Testconditons	Min	Typ	Max	Unit
Gate Threshold Voltage	V _{GS(th)}	V _{DS} = V _{GS} , I _D = 250 μA	0.6		1.5	V
Gate-Body Leakage	I _{GSS}	V _{DS} = 0 V, V _{GS} = ±12 V			±100	nA
Zero Gate Voltage Drain Current	I _{DSS}	V _{DS} = 20 V, V _{GS} = 0 V			1	μA
		V _{DS} = 20 V, V _{GS} = 0 V, T _J = 85°C			5	μA
On-State Drain Current*	I _{D(on)}	V _{DS} ≥ 5 V, V _{GS} = 4.5 V	20			A
Drain-Source On-State Resistance*	r _{DS(on)}	V _{GS} = 4.5 V, I _D = 5.4 A		0.022	0.028	Ω
		V _{GS} = 2.5 V, I _D = 2.6 A		0.031	0.039	Ω
Forward Transconductance*	g _{fs}	V _{DS} = 10 V, I _D = 5.4 A		26		S
Schottky Diode Forward Voltage*	V _{SD}	I _S = 1.1 A, V _{GS} = 0 V		0.7		V
Total Gate Charge	Q _g	V _{DS} = 10 V, V _{GS} = 4.5 V, I _D = 5.4 A		7	11	nC
Gate-Source Charge	Q _{gs}			1.7		nC
Gate-Drain Charge	Q _{gd}			2		nC
Gate Resistance	R _g			1.7		Ω
Turn-On Delay Time	t _{d(on)}	V _{DD} = 10 V, R _L = 10 Ω I _D = 1 A, V _{GEN} = 4.5V, R _G = 6 Ω		12	20	ns
Rise Time	t _r			12	20	ns
Turn-Off Delay Time	t _{d(off)}			25	40	ns
Fall Time	t _f			10	20	ns
Source-Drain Reverse Recovery Time	t _{rr}		I _F = 1.1 A, di/dt = 100 A/μs		20	40

* Pulse test; pulse width ≤ 300 μs, duty cycle ≤ 2%.