

## WIDE INPUT 2A STEP DOWN CONVERTER

## FSP3170

## Features

- 2A Output Current
- Up to 90% Efficiency
- 4.75V to 20V Input Range
- 40 $\mu$ A Shutdown Supply Current
- 400kHz Switching Frequency
- Adjustable Output Voltage
- Cycle-by-Cycle Current Limit Protection
- Thermal Shutdown Protection
- Frequency Foldback at Short Circuit
- Stability with Wide Range of Capacitors, Including Low ESR Ceramic Capacitors
- SOP8L Package

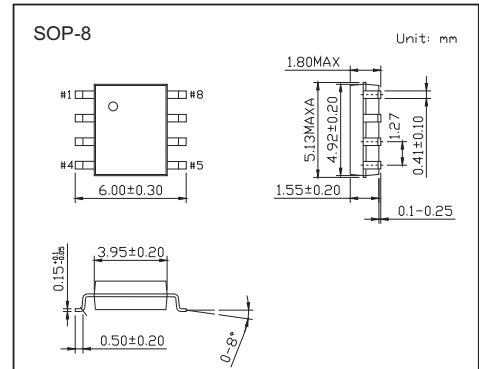

## Functional Block Diagram

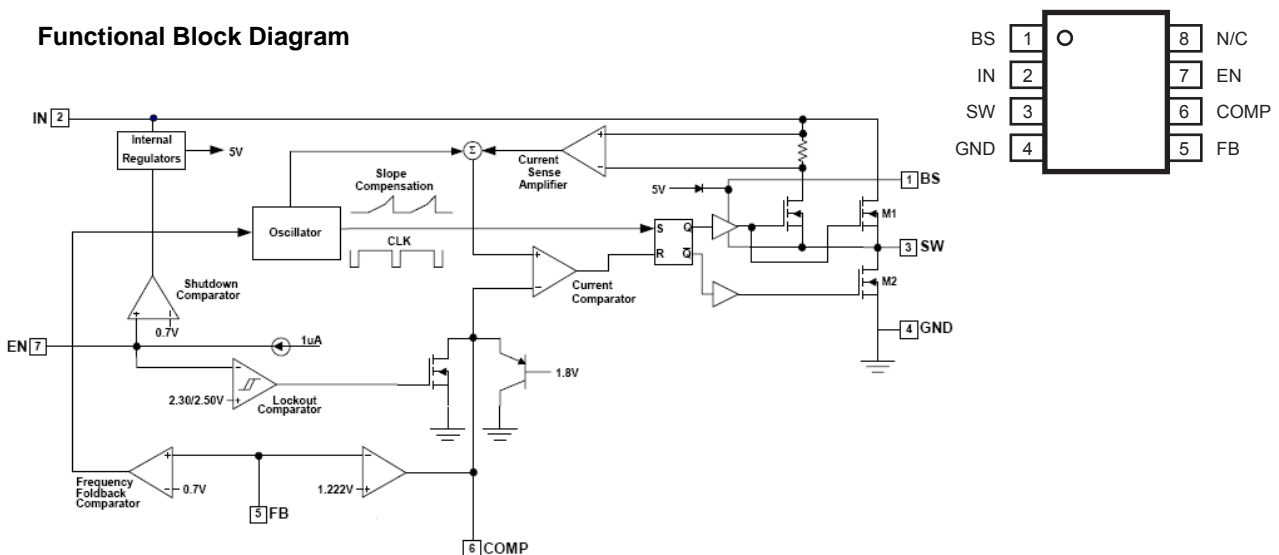
Absolute Maximum Ratings  $T_a = 25^\circ\text{C}$ 

Parameter	Value	Unit
IN Supply Voltage	-0.3 to 20	V
SW Voltage	-1 to $V_{IN} + 1$	V
BS Voltage	$V_{SW} - 0.3$ to $V_{SW} + 8$	V
EN, FB, COMP Voltage	-0.3 to 20	V
Continuous SW Current	Internally limited	A
Junction to Ambient Thermal Resistance ( $\theta_{JA}$ )	105	$^\circ\text{C}/\text{W}$
Junction to Ambient Case Resistance ( $\theta_{JC}$ )	50	$^\circ\text{C}/\text{W}$
Maximum Power Dissipation	0.76	W
Operating Junction Temperature	-40 to 150	$^\circ\text{C}$
Storage Temperature	-55 to 150	$^\circ\text{C}$
Lead Temperature (Soldering, 10 sec)	300	$^\circ\text{C}$

(Note: Exceeding these limits may damage the device. Exposure to absolute maximum rating conditions for long periods may affect device reliability.)

## FSP3170

Electrical Characteristics ( $T_a = 25^\circ\text{C}$ ,  $V_{EN}=5\text{V}$ ,  $V_{IN}=12\text{V}$ , unless otherwise specified)

Parameter	Symbol	Test Conditions	Min.	Typ.	Max.	Unit
Input Voltage	$V_{IN}$	$V_{OUT} = 5\text{V}$ , $I_{LOAD} = 0\text{A to } 1\text{A}$	7		18	V
Feedback Voltage	$V_{FB}$	$4.75\text{V} \leq V_{IN} \leq 20\text{V}$ , $V_{COMP} = 1.5\text{V}$	1.185	1.222	1.258	V
Saturation voltage of output driver	$V_{CEsat}$	$V_{IN}=12\text{V}$ $I_{LOAD}=1\text{A}$		500		mV
SW Leakage		$V_{EN} = 0$		0	10	$\mu\text{A}$
Current Limit	$I_{LIMIT}$			2.6		A
COMP to Current Limit Transconductance	$G_{COMP}$			2.5		A/V
Error Amplifier Transconductance	$G_{EA}$	$\Delta I_{COMP} = \pm 10\mu\text{A}$		850		$\mu\text{A/V}$
Error Amplifier DC Gain	$A_{VEA}$			350		V/V
Switching Frequency	$f_{SW}$		350	400	470	kHz
Short Circuit Switching Frequency		$V_{FB} = 0$		50		kHz
Maximum Duty Cycle	$D_{MAX}$	$V_{FB} = 1.1\text{V}$		90	95	%
Minimum Duty Cycle		$V_{FB} = 1.4\text{V}$			0	%
$V_{COMP}$ Pin Maximum Switching Threshold		Duty cycle = 0%		0.35		V
Minimum Boost Voltage Above Switch		$I_{SW} = 2\text{A}$		1.8	2.7	V
Enable Threshold Voltage		Hysteresis = 0.1V	0.7	1	1.3	V
Enable Pull Up Current		Pin pulled up to 4.5V typically when left unconnected		2		$\mu\text{A}$
Supply Current in Shutdown		$V_{EN} = 0$		8	40	$\mu\text{A}$
IC Supply Current in Operation		$V_{EN} = 3\text{V}$ , $V_{FB} = 1.4\text{V}$		2.2		mA
Thermal Shutdown Temperature		Hysteresis = $10^\circ\text{C}$		160		$^\circ\text{C}$

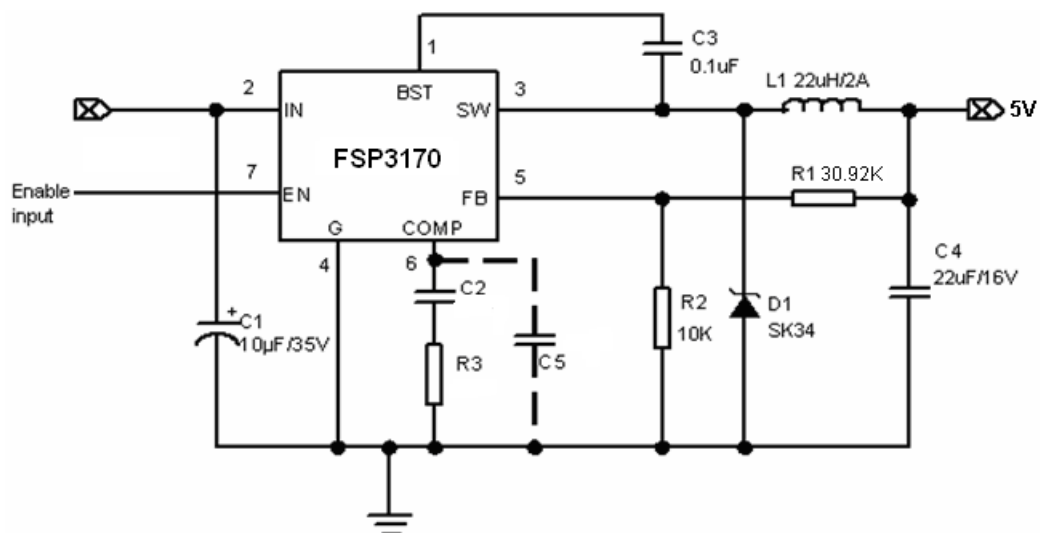

Figure1. FSP3170 5V/2A Output Application

# FSP3170

## Typical Characteristics

