

N-channel enhancement mode MOSFET

2SK3731

■ Features

- Low on-resistance, low Qg
- High avalanche resistance
- For high-speed switching

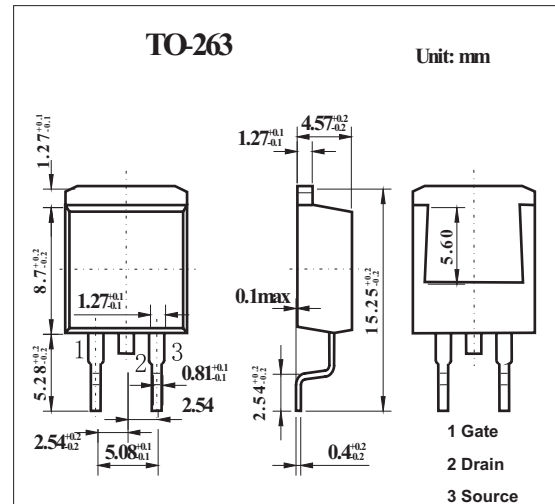

■ Absolute Maximum Ratings Ta = 25°C

Parameter	Symbol	Rating	Unit
Drain-source surrender voltage	V _{DSS}	230	V
Gate-source surrender voltage	V _{GSS}	±30	V
Drain current	I _D	20	A
Peak drain current	I _{DP}	80	A
Avalanche energy capability *	E _{AS}	668	mJ
Power dissipation	P _D	50	W
Power dissipation Ta = 25°C		1.4	
Channel temperature	T _{ch}	150	°C
Storage temperature	T _{stg}	-55 to +150	°C

*: L = 2.79 mH, I_L = 20 A, V_{DD} = 50 V, 1 pulse, Ta = 25°C

2SK3731

■ Electrical Characteristics Ta = 25°C

Parameter	Symbol	Testconditions	Min	Typ	Max	Unit
Drain-source surrender voltage	V _{DSS}	I _D = 1 mA, V _{GS} = 0	230			V
Gate threshold voltage	V _{th}	V _{DS} = 10 V, I _D = 1 mA	2.0		4.0	V
Drain-source cutoff current	I _{DSS}	V _{DS} = 184 V, V _{GS} = 0			10	μA
Gate-source cutoff current	I _{GSS}	V _{GS} = ±30 V, V _{DS} = 0			±1	μA
Drain-source ON resistance	R _{DS(on)}	V _{GS} = 10 V, I _D = 10 A		65	82	mΩ
Forward transfer admittance	Y _{fs}	V _{DS} = 10 V, I _D = 10 A	7	14		S
Short-circuit forward transfer capacitance	C _{iss}	V _{DS} = 25 V, V _{GS} = 0, f = 1 MHz		360		pF
Short-circuit output capacitance	C _{oss}			394		pF
Reverse transfer capacitance	C _{rss}			49		pF
Turn-on delay time	t _{d(on)}	V _{DD} ≈ 100 V, I _D = 10 A R _L = 10Ω, V _{GS} = 10 V		31		ns
Rise time	T _r			27		ns
Turn-off delay time	t _{d(off)}			214		ns
Fall time	t _f			47		ns
Diode forward voltage	V _{DSF}	I _{DR} = 20 A, V _{GS} = 0			21.5	V
Reverse recovery time	t _{rr}	L = 230 μH, V _{DD} = 100 V I _{DR} = 10 A, di/dt = 100 A/μs		142		ns
Reverse recovery charge	Q _{rr}			668		nC
Gate charge load	Q _g	V _{DD} = 100 V, I _D = 10 A, V _{GS} = 10 V		43		nC
Gate-source charge	Q _{gs}			6.6		nC
Gate-drain charge	Q _{gd}			16		nC
Thermal resistance (ch-c)	R _{th(ch-c)}					2.5
Thermal resistance (ch-a)	R _{th(ch-a)}				89.2	°C/W