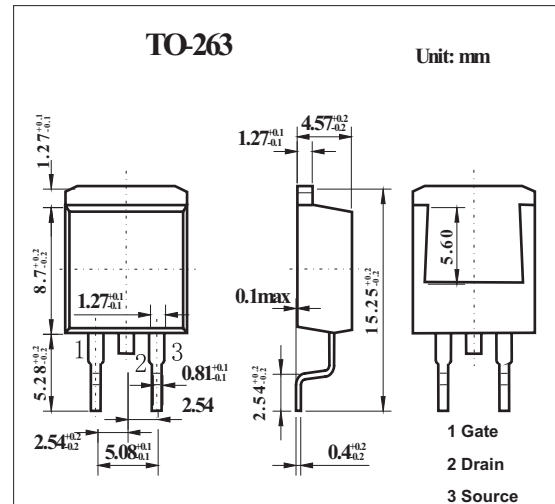
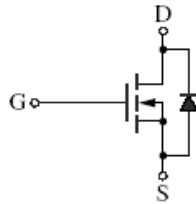

N-channel Enhancement Mode MOSFET

2SK3723

■ Features

- Low on-resistance, low Q_g
- High avalanche resistance
- For high-speed switching

■ Absolute Maximum Ratings $T_a = 25^\circ\text{C}$

Parameter	Symbol	Rating	Unit
Drain-source surrender voltage	V_{DSS}	150	V
Gate-source surrender voltage	V_{GSS}	± 30	V
Drain current	I_D	30	A
Peak drain current	I_{DP}	120	A
Power dissipation	P_D	50	W
Power dissipation $T_a = 25^\circ\text{C}$		3	
Channel temperature	T_{ch}	150	$^\circ\text{C}$
Storage temperature	T_{stg}	-55 to +150	$^\circ\text{C}$

2SK3723

■ Electrical Characteristics Ta = 25°C

Parameter	Symbol	Testconditions	Min	Typ	Max	Unit
Drain-source surrender voltage	V _{DSS}	I _D = 1 mA, V _{GS} = 0	150			V
Gate threshold voltage	V _{th}	V _{DS} = 25 V, I _D = 1 mA	2		4	V
Drain-source cutoff current	I _{DSS}	V _{DS} = 120 V, V _{GS} = 0			100	μA
Gate-source cutoff current	I _{GSS}	V _{GS} = ±30 V, V _{DS} = 0			±1	μA
Drain-source ON resistance	R _{DS(on)}	V _{GS} = 10 V, I _D = 15 A		33	42	mΩ
Forward transfer admittance	Y _{fs}	V _{DS} = 25 V, I _D = 15 A	8	18		S
Short-circuit forward transfer capacitance	C _{iss}	V _{DS} = 25 V, V _{GS} = 0, f = 1 MHz		2 900		pF
Short-circuit output capacitance	C _{oss}			618		pF
Reverse transfer capacitance	C _{rss}			91		pF
Turn-on delay time	t _{d(on)}	V _{DD} ≈ 100 V, I _D = 15 A, R _L = 6.7 Ω, V _{GS} = 10 V		32		ns
Rise time	T _r			46		ns
Turn-off delay time	t _{d(off)}			227		ns
Fall time	t _f			66		ns
Diode forward voltage	V _{DSF}	I _{DR} = 30 A, V _{GS} = 0			-1.5	V
Reverse recovery time	t _{rr}	L = 230 μH, V _{DD} = 100 V		130		ns
Reverse recovery charge	Q _{rr}	I _{DR} = 15 A, di/dt = 100 A/μs		533		nC
Gate charge load	Q _g	V _{DD} = 100 V, I _D = 15 A, V _{GS} = 10 V		55.4		nC
Gate-source charge	Q _{gs}			9.1		nC
Gate-drain charge	Q _{gd}			22.4		nC
Thermal resistance (ch-c)	R _{th(ch-c)}				2.5	°C/W
Thermal resistance (ch-a)	R _{th(ch-a)}				89.2	°C/W

■ Marking

Marking	K3723
---------	-------