

MOS Field Effect Transistor

2SK3716

■ Features

- Super low on-state resistance:
 $R_{DS(on)1} = 6.5 \text{ m}\Omega \text{ MAX. (} V_{GS} = 10 \text{ V, } I_D = 30 \text{ A)}$
 $R_{DS(on)2} = 9.1 \text{ m}\Omega \text{ MAX. (} V_{GS} = 4.5 \text{ V, } I_D = 30 \text{ A)}$
- Low C_{iss} : $C_{iss} = 2700 \text{ pF TYP.}$
- Built-in gate protection diode

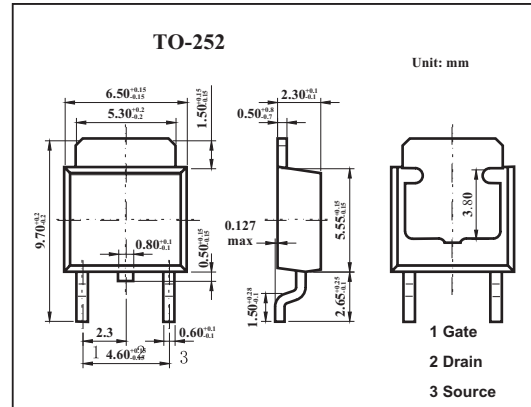

■ Absolute Maximum Ratings $T_a = 25^\circ\text{C}$

Parameter	Symbol	Rating	Unit	
Drain to source voltage	V_{DS}	40	V	
Gate to source voltage	V_{GS}	± 20	V	
Drain current	I_D	± 60	A	
	I_{DP}^*	± 240	A	
Power dissipation	P_D	$T_A=25^\circ\text{C}$	1.0	W
		$T_C=25^\circ\text{C}$	84	
Channel temperature	T_{ch}	150	$^\circ\text{C}$	
Storage temperature	T_{stg}	-55 to +150	$^\circ\text{C}$	

* $PW \leq 10 \mu\text{s}$, Duty Cycle $\leq 1\%$

■ Electrical Characteristics $T_a = 25^\circ\text{C}$

Parameter	Symbol	Test conditions	Min	Typ	Max	Unit
Drain cut-off current	I_{DSS}	$V_{DS}=40\text{V}, V_{GS}=0$			10	μA
Gate leakage current	I_{GSS}	$V_{GS} = \pm 20\text{V}, V_{DS}=0$			± 10	μA
Gate cut off voltage	$V_{GS(off)}$	$V_{DS}=10\text{V}, I_D=1\text{mA}$	1.5	2.0	2.5	V
Forward transfer admittance	$ Y_{fs} $	$V_{DS}=10\text{V}, I_D=30\text{A}$	22	43		S
Drain to source on-state resistance	$R_{DS(on)1}$	$V_{GS}=10\text{V}, I_D=30\text{A}$		5.2	6.5	$\text{m}\Omega$
	$R_{DS(on)2}$	$V_{GS}=4.5\text{V}, I_D=30\text{A}$		6.6	9.1	$\text{m}\Omega$
Input capacitance	C_{iss}	$V_{DS}=10\text{V}, V_{GS}=0, f=1\text{MHz}$		2700		pF
Output capacitance	C_{oss}			770		pF
Reverse transfer capacitance	C_{rss}			290		pF
Turn-on delay time	t_{on}	$I_D=30\text{A}, V_{GS(on)}=10\text{V}, R_G=0\Omega, V_{DD}=20\text{V}$		11		ns
Rise time	t_r			13		ns
Turn-off delay time	t_{off}			69		ns
Fall time	t_f			14		ns
Total Gate Charge	Q_G		$V_{DD} = 32\text{V}$		50	
Gate to Source Charge	Q_{GS}	$V_{GS} = 10 \text{ V}$		9		nC
Gate to Drain Charge	Q_{GD}	$I_D = 60\text{A}$		13		nC