

## Silicon N-channel Power MOSFET

## 2SK3628

## ■ Features

- High-speed switching
- Low ON resistance Ron
- No secondary breakdown
- Avalanche energy capability guaranteed

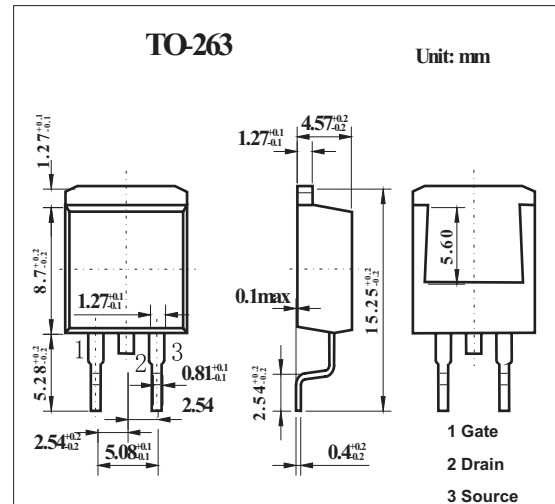

## ■ Absolute Maximum Ratings Ta = 25°C

Parameter	Symbol	Rating	Unit
Drain-source surrender voltage	V <sub>DS</sub>	230	V
Gate-source surrender voltage	V <sub>GS</sub>	±30	V
Drain current	I <sub>D</sub>	20	A
Peak drain current	I <sub>DP</sub>	80	A
Avalanche energy capability	E <sub>AS</sub>	570	mJ
Power dissipation Ta = 25°C	P <sub>D</sub>	3	W
Power dissipation		100	
Channel temperature	T <sub>ch</sub>	150	°C
Storage temperature	T <sub>stg</sub>	-55 to +150	°C

## 2SK3628

## ■ Electrical Characteristics Ta = 25°C

Parameter	Symbol	Testconditons	Min	Typ	Max	Unit
Gate-drain surrender voltage	V <sub>DSS</sub>	I <sub>D</sub> = 1 mA, V <sub>GS</sub> = 0	230			V
Diode forward voltage	V <sub>DSF</sub>	I <sub>DR</sub> = 20 A, V <sub>GS</sub> = 0			-1.5	V
Gate threshold voltage	V <sub>th</sub>	V <sub>DS</sub> = 25 V, I <sub>D</sub> = 1 mA	1.7		3.7	V
Drain-source cutoff current	I <sub>DSS</sub>	V <sub>DS</sub> = 184 V, V <sub>GS</sub> = 0			100	μA
Gate-source cutoff currentt	I <sub>GSS</sub>	V <sub>GS</sub> = ±30 V, V <sub>DS</sub> = 0			±1	μA
Drain-source on resistance	R <sub>DS(on)</sub>	V <sub>GS</sub> = 10 V, I <sub>D</sub> = 10 A		65	85	mΩ
Forward transfer admittance	Y <sub>fs</sub>	V <sub>DS</sub> = 25 V, I <sub>D</sub> = 10 A	7	14		S
Short-circuit forward transfer capacitance	C <sub>iss</sub>	V <sub>DS</sub> = 25 V, V <sub>GS</sub> = 0, f = 1 MHz		2300		pF
Short-circuit output capacitance	C <sub>oss</sub>			330		pF
Reverse transfer capacitance	C <sub>rss</sub>			30		pF
Turn-on delay time	t <sub>d(on)</sub>	V <sub>DD</sub> ≈ 100 V, I <sub>D</sub> = 15 A R <sub>L</sub> = 6.7 Ω, V <sub>GS</sub> = 10 V		35		ns
Rise time	t <sub>r</sub>			26		ns
Turn-off delay time	t <sub>d(off)</sub>			220		ns
Fall time	t <sub>f</sub>			36		ns