

MOS Field Effect Transistor 2SK3570

Features

- 4.5V drive available.
- Low on-state resistance,
 $R_{DS(on)1} = 12 \text{ m}\Omega \text{ MAX. (} V_{GS} = 10 \text{ V, } I_D = 24 \text{ A)}$
- Low gate charge
 $Q_G = 23 \text{ nC TYP. (} V_{DD} = 16 \text{ V, } V_{GS} = 10 \text{ V, } I_D = 48 \text{ A)}$
- Built-in gate protection diode
- Surface mount device available

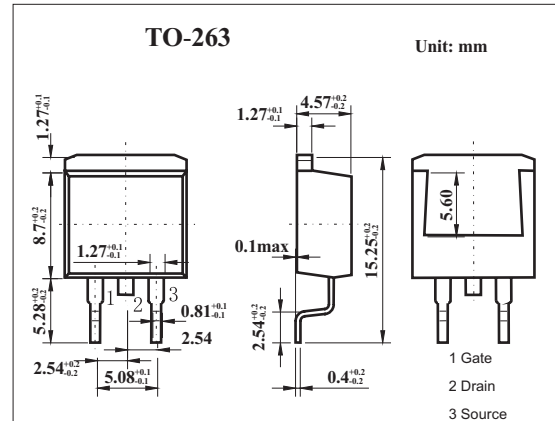

Absolute Maximum Ratings $T_a = 25^\circ\text{C}$

Parameter	Symbol	Rating	Unit
Drain to source voltage	V_{DSS}	20	V
Gate to source voltage	V_{GSS}	± 20	V
Drain current	I_D	± 48	A
	I_{dp}^*	± 160	A
Power dissipation	PD	$T_c=25^\circ\text{C}$	29
		$T_A=25^\circ\text{C}$	1.5
Channel temperature	T_{ch}	150	$^\circ\text{C}$
Storage temperature	T_{stg}	-55 to +150	$^\circ\text{C}$

* $PW \leq 10 \mu\text{s}$, Duty Cycle $\leq 1\%$

Electrical Characteristics $T_a = 25^\circ\text{C}$

Parameter	Symbol	Testconditions	Min	Typ	Max	Unit
Drain cut-off current	I_{DSS}	$V_{DS}=20\text{V}, V_{GS}=0$			10	μA
Gate leakage current	I_{GSS}	$V_{GS}=\pm 20\text{V}, V_{DS}=0$			± 10	μA
Gate cut off voltage	$V_{GS(off)}$	$V_{DS}=10\text{V}, I_D=1\text{mA}$	1.5		2.5	V
Forward transfer admittance	$ Y_{fs} $	$V_{DS}=10\text{V}, I_D=24\text{A}$	8.0			S
Drain to source on-state resistance	$R_{DS(on)1}$	$V_{GS}=10\text{V}, I_D=24\text{A}$		8.2	12	$\text{m}\Omega$
	$R_{DS(on)2}$	$V_{GS}=4.5\text{V}, I_D=15\text{A}$		12.3	22	$\text{m}\Omega$
Input capacitance	C_{iss}	$V_{DS}=10\text{V}, V_{GS}=0, f=1\text{MHz}$		930		pF
Output capacitance	C_{oss}			360		pF
Reverse transfer capacitance	C_{rss}			250		pF
Turn-on delay time	t_{on}	$I_D=24\text{A}, V_{GS(on)}=10\text{V}, R_G=10\Omega, V_{DD}=10\text{V}$		13		ns
Rise time	t_r			20		ns
Turn-off delay time	t_{off}			39		ns
Fall time	t_f			14		ns
Total Gate Charge	Q_G		$V_{DD} = 16 \text{ V}$		23	
Gate to Source Charge	Q_{GS}	$V_{GS} = 10 \text{ V}$		4		nC
Gate to Drain Charge	Q_{GD}	$I_D = 48 \text{ A}$		7		nC