

MOS Field Effect Transistor 2SK3112

■ Features

- Gate voltage rating ± 30 V
- Low on-state resistance
 $R_{DS(on)} = 110\text{m}\Omega$ MAX. ($V_{GS} = 10$ V, $I_D = 13$ A)
- Low input capacitance
 $C_{iss} = 1600$ pF TYP. ($V_{DS} = 10$ V, $V_{GS} = 0$ V)
- Avalanche capability rated
- Built-in gate protection diode
- Surface mount device available

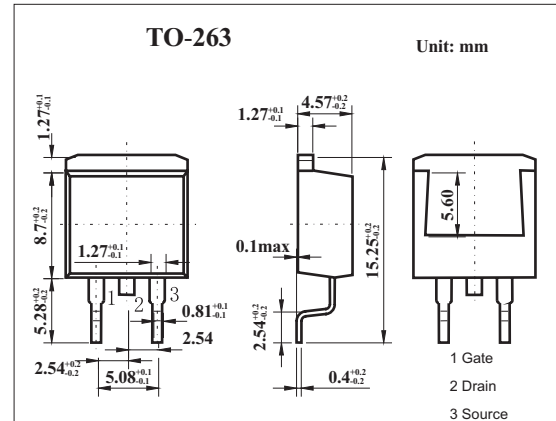
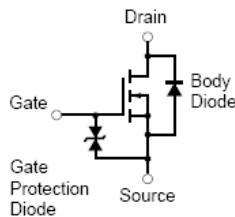

■ Absolute Maximum Ratings $T_a = 25^\circ\text{C}$

Parameter	Symbol	Rating	Unit	
Drain to source voltage	V_{DS}	200	V	
Gate to source voltage	V_{GS}	± 30	V	
Drain current	I_D	± 25	A	
	I_{DP}^*	± 75	A	
Power dissipation	P_D	$T_c=25^\circ\text{C}$	100	W
		$T_A=25^\circ\text{C}$	1.5	
Channel temperature	T_{ch}	150	$^\circ\text{C}$	
Storage temperature	T_{stg}	-55 to +150	$^\circ\text{C}$	

* $PW \leq 10 \mu\text{s}$, Duty Cycle $\leq 1\%$

■ Electrical Characteristics $T_a = 25^\circ\text{C}$

Parameter	Symbol	Test conditions	Min	Typ	Max	Unit
Drain cut-off current	I_{DSS}	$V_{DS}=200\text{V}, V_{GS}=0$			100	μA
Gate leakage current	I_{GSS}	$V_{GS}=\pm 30\text{V}, V_{DS}=0$			± 10	μA
Gate to source cut off voltage	$V_{GS(off)}$	$V_{DS}=10\text{V}, I_D=1\text{mA}$	2.5		4.5	V
Forward transfer admittance	$ Y_{fs} $	$V_{DS}=10\text{V}, I_D=13\text{A}$	6.0			S
Drain to source on-state resistance	$R_{DS(on)}$	$V_{GS}=10\text{V}, I_D=13\text{A}$		76	110	$\text{m}\Omega$
Input capacitance	C_{iss}	$V_{DS}=10\text{V}, V_{GS}=0, f=1\text{MHz}$		1600		pF
Output capacitance	C_{oss}			430		pF
Reverse transfer capacitance	C_{rss}			280		pF
Turn-on delay time	t_{on}	$I_D=13\text{A}, V_{GS(on)}=10\text{V}, V_{DD}=100\text{V}, R_G=10\Omega$		35		ns
Rise time	t_r			140		ns
Turn-off delay time	t_{off}			110		ns
Fall time	t_f			70		ns