

MOS Field Effect Transistor

2SJ606

■ Features

- Low on-resistance
 $R_{DS(on)1} = 15 \text{ m}\Omega \text{ MAX. (} V_{GS} = -10 \text{ V, } I_D = -42 \text{ A)}$
 $R_{DS(on)2} = 23 \text{ m}\Omega \text{ MAX. (} V_{GS} = -4.0 \text{ V, } I_D = -42 \text{ A)}$
- Low C_{iss} : $C_{iss} = 4800 \text{ pF TYP.}$
- Built-in gate protection diode

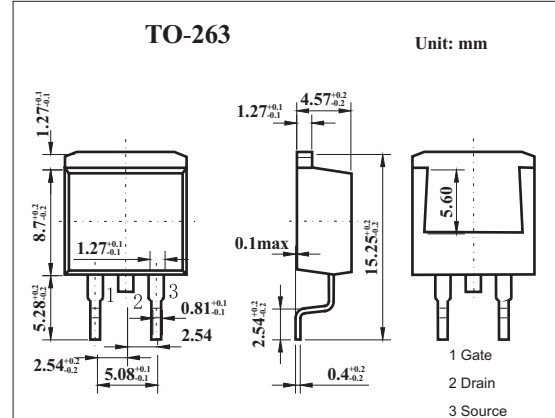
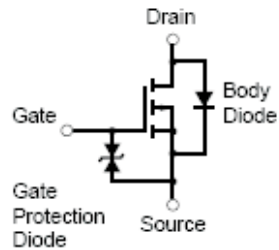

■ Absolute Maximum Ratings $T_a = 25^\circ\text{C}$

Parameter	Symbol	Rating	Unit	
Drain to source voltage	V_{DS}	-60	V	
Gate to source voltage	V_{GS}	± 20	V	
Drain current (DC)	I_D	± 83	A	
Drain current(pulse) *	I_D	± 300	A	
Power dissipation	$T_C=25^\circ\text{C}$	P_D	120	W
	$T_A=25^\circ\text{C}$	P_D	1.5	W
Channel temperature	T_{ch}	150	$^\circ\text{C}$	
Storage temperature	T_{stg}	-55 to +150	$^\circ\text{C}$	

* $PW \leq 10 \mu\text{s}$, duty cycle $\leq 1\%$

2SJ606

■ Electrical Characteristics Ta = 25°C

Parameter	Symbol	Testconditions	Min	Typ	Max	Unit
Drain cut-off current	I _{DSS}	V _{DS} =-60V, V _{GS} =0			-10	μ A
Gate leakage current	I _{GSS}	V _{GS} =±20V, V _{DS} =0			±10	μ A
Gate to source cutoff voltage	V _{GS(off)}	V _{DS} =-10V, I _D =-1mA	-1.5	-2.0	-2.5	V
Forward transfer admittance	Y _{fs}	V _{DS} =-10V, I _D =-42A	38	74		S
Drain to source on-state resistance	R _{DS(on)}	V _{GS} =-10V, I _D =-42A		12	15	m Ω
		V _{GS} =-4.0V, I _D =-42A		16	23	m Ω
Input capacitance	C _{iss}	V _{DS} =-10V, V _{GS} =0, f=1MHZ		4800		pF
Output capacitance	C _{oss}			1200		pF
Reverse transfer capacitance	C _{rss}			340		pF
Turn-on delay time	t _{d(on)}	V _{GS(on)} =-30V, I _D =-42A, V _{DD} =-10V, R _G =0 Ω		13		ns
Rise time	t _r			13		ns
Turn-off delay time	t _{d(off)}			290		ns
Fall time	t _f			160		ns
Total Gate Charge	Q _G	I _D = -83A		120		nC
Gate to Source Charge	Q _{GS}	V _{DD} = -48 V		20		nC
Gate to Drain Charge	Q _{GD}	V _{GS} = -10 V		30		nC
Body Diode Forward Voltage	V _{F(S-D)}	I _F = 83A, V _{GS} = 0 V		1.1		V
Reverse Recovery Time	t _{rr}	I _F = 83 A, V _{GS} = 0 V		60		ns
Reverse Recovery Charge	Q _{rr}	di/dt = 100 A / μ s		120		nC