

MOS Field Effect Transistor

2SJ492

■ Features

- Low on-state resistance
 $R_{DS(on)1} = 100 \text{ m}\Omega$ (MAX.) ($V_{GS} = -10 \text{ V}$, $I_D = -10 \text{ A}$)
 $R_{DS(on)2} = 185 \text{ m}\Omega$ (MAX.) ($V_{GS} = -4 \text{ V}$, $I_D = -10 \text{ A}$)
- Low C_{iss} : $C_{iss} = 1210 \text{ pF}$ (TYP.)
- Built-in gate protection diode

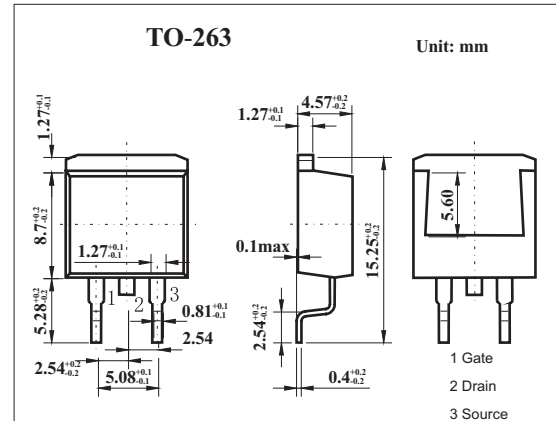
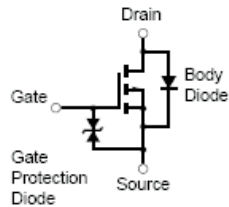

■ Absolute Maximum Ratings $T_a = 25^\circ\text{C}$

Parameter	Symbol	Rating	Unit	
Drain to source voltage	V_{DSS}	-60	V	
Gate to source voltage (AC)	V_{GSS}	± 20	V	
Gate to source voltage (DC) *1	V_{GSS}	-20	V	
Drain current (DC)	I_D	± 20	A	
Drain current(pulse) *2	I_D	± 80	A	
Power dissipation	$T_A=25^\circ\text{C}$	P_D	1.5	W
	$T_C=25^\circ\text{C}$	P_D	70	W
Channel temperature	T_{ch}	150	$^\circ\text{C}$	
Storage temperature	T_{stg}	-55 to +150	$^\circ\text{C}$	
Channel to Case	$R_{th(ch-C)}$	1.79	$^\circ\text{C/W}$	
Channel to Ambient	$R_{th(ch-A)}$	83.3	$^\circ\text{C/W}$	

*1 $f = 20 \text{ kHz}$, Duty Cycle $\leq 10\%$ (+Side)

*2 $PW \leq 10 \mu\text{s}$; $d \leq 1\%$.

2SJ492

■ Electrical Characteristics Ta = 25°C

Parameter	Symbol	Testconditions	Min	Typ	Max	Unit
Drain to source breakdown voltage	V _{DSS}	I _D =-10mA, V _{GS} =0	-20			V
Gate to source breakdown voltage	V _{GSS}	I _G =±200 μA, V _{DS} =0	±10			V
Drain cut-off current	I _{DSS}	V _{DS} =-60V, V _{GS} =0			-10	μA
Gate leakage current	I _{GSS}	V _{GS} =±20V, V _{DS} =0			±10	μA
Gate to source cutoff voltage	V _{GS(off)}	V _{DS} =-10V, I _D =-1mA	-1.0	-1.5	-2.0	V
Forward transfer admittance	Y _{fs}	V _{DS} =-10V, I _D =-10A	5.0	12		S
Drain to source on-state resistance	R _{DS(on)}	V _{GS} =-10V, I _D =-10A		70	100	mΩ
		V _{GS} =-4.0V, I _D =-10A		120	185	mΩ
Input capacitance	C _{iss}			1210		pF
Output capacitance	C _{oss}	V _{DS} =-10V, V _{GS} =0, f=1MHZ		520		pF
Reverse transfer capacitance	C _{rss}			180		pF
Turn-on delay time	t _{d(on)}			16		ns
Rise time	t _r	V _{DD} =-30V, V _{GS(on)} =-10V, I _D =-10A		140		ns
Turn-off delay time	t _{d(off)}	, R _G =10Ω		90		ns
Fall time	t _f			80		ns