

SURFACE MOUNT TRANSIENT VOLTAGE SUPPRESSOR

P6SMBJ12A

Features

For surface mounted applications in order to optimize board space.

Low profile package

Built-in strain relief

Glass passivated junction

Excellent clamping capability

Low inductance

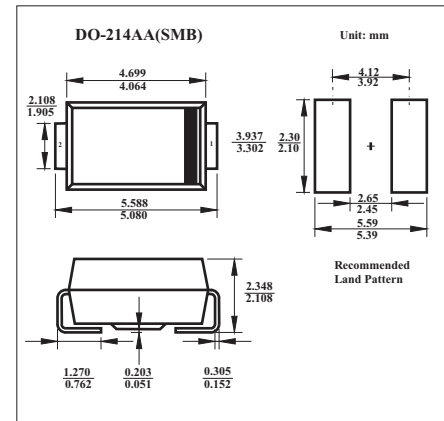
Absolute Maximum Ratings $T_a = 25^\circ\text{C}$

Parameter	Symbol	Ratings	Units
Peak Power Dissipation at $T_a=25^\circ\text{C}$, $T_P=1\text{ms}$ (Note 1,2)	PPPM	Minimum 600	W
Peak Forward Surge Current (Note 2,3)	IFSM	100	A
Peak Pulse Current Current on 10/1000 μs waveform (Note 1)	IPPM	See Table	A
Operating and Storage Temperature Range	T_j, T_{STG}	-55 to +150	$^\circ\text{C}$

Electrical Characteristics $T_a = 25^\circ\text{C}$

Part Number	Reverse Stand-off Voltage	Breakdown Voltage		Test Current	Reverse Leakage	Max. Clamp Voltage	Peak Pulse Current
	VRWM	VBR @ IT		IT	IR @ VRWM	VC @ IPP	IPP
		Min.	Max.				
	V	V	V	mA	μA	V	A
P6SMBJ12A	12	13.3	15.3	1.0	5	19.9	30.2

NOTES:

- 1.Non-repetitive current pulse, per Fig. 3 and derated above $T_a=25^\circ\text{C}$ per
- 2.Mounted on 5.0mm² (.013mm thick) land areas.
- 3.Measured on 8.3ms , single half sine-wave or equivalent square wave , duty cycle= 4 pulses per minutes maximum.

Marking

Marking	LE
---------	----

P6SMBJ12A

Typical Characteristics

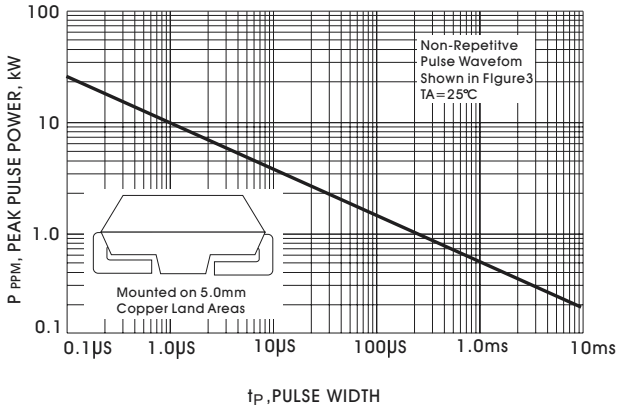

Figure 1, Peak Pulse Power Rating Curve

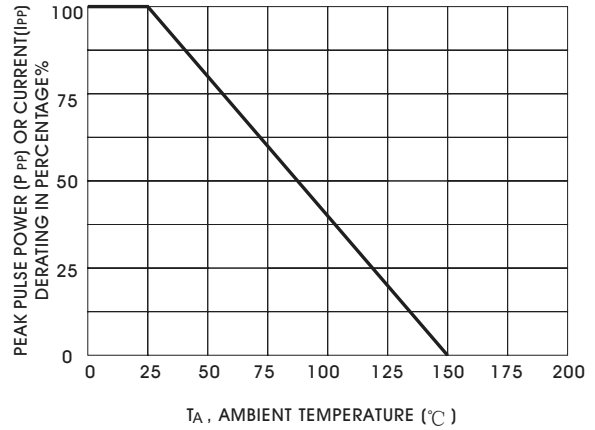

Figure 2, Derating Curve

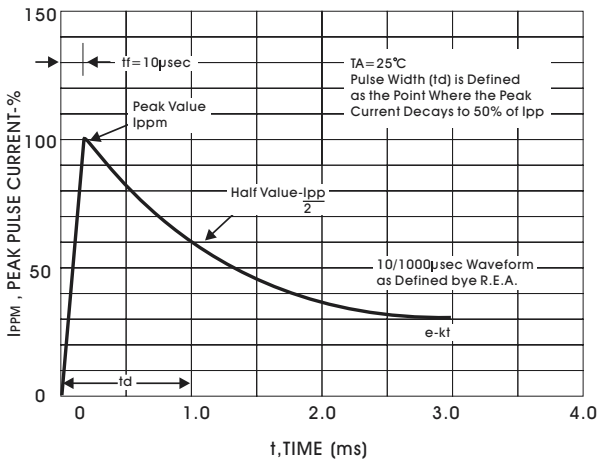

Figure 3, Pulse Waveform

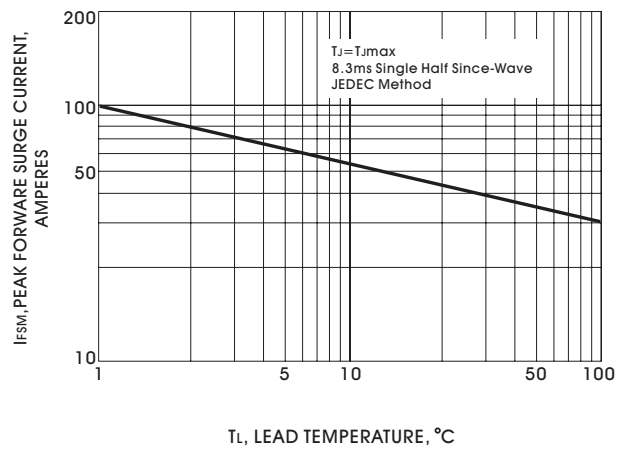

Figure 4, Maximum Non-Repetitive Peak Forward Surge Current

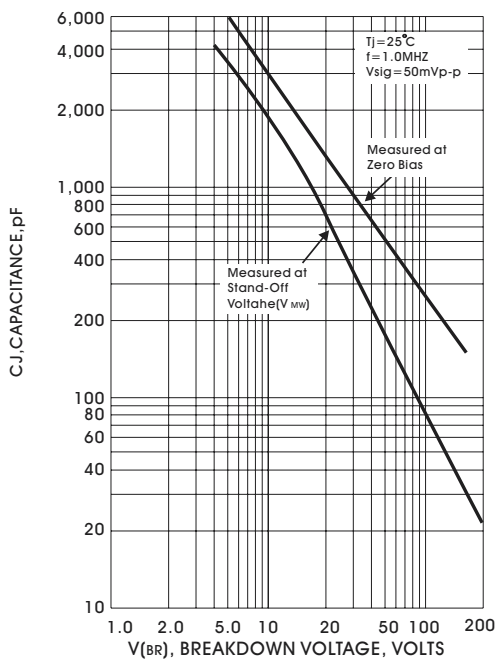

Figure 5, Typical Capacitance