

SURFACE MOUNT TRANSIENT VOLTAGE SUPPRESSOR

P4SMAJ6.0A

Features

For surface mounted applications in order to optimize board space.

Low profile package

Built-in strain relief

Glass passivated junction

Excellent clamping capability

Low inductance

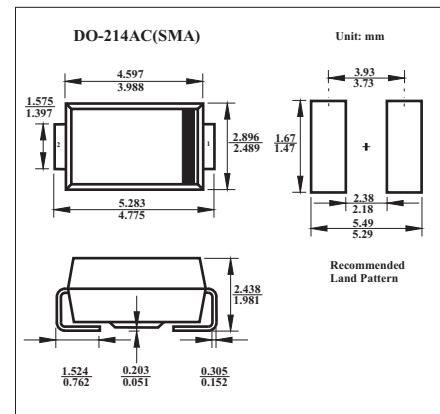
Absolute Maximum Ratings $T_a = 25^\circ\text{C}$

Parameter	Symbol	Ratings	Units
Peak Power Dissipation at $T_a=25^\circ\text{C}$, $T_P=1\text{ms}$ (Note 1,2,5)	PPPM	Minimum 400	W
Steady State Power Dissipation (Note 3)	PM(AV)	1	W
Peak Forward Surge Current (Note 4)	IFSM	40	A
Peak Pulse Current Current on 10/1000 μs waveform (Note 1,2,5)	IPPM	See Table	A
Operating and Storage Temperature Range	T_j, T_{STG}	-55 to +150	$^\circ\text{C}$

Electrical Characteristics $T_a = 25^\circ\text{C}$

Part Number	Reverse Stand-off Voltage	Breakdown Voltage		Test Current	Reverse Leakage	Max. Clamp Voltage	Peak Pulse Current
	V_{RWM}	$V_{BR} @ I_T$		I_T	$I_R @ V_{RWM}$	$V_C @ I_{PP}$	I_{PP}
		Min.	Max.				
P4SMAJ6.0A	6.0	6.67	7.67	10	800	10.3	38.8

NOTES:

1. Non-repetitive current pulse and derated above $T_a = 25^\circ\text{C}$
2. Mounted on 5.0mm² copper pad to each terminal.
3. lead temperature at 75°C .
4. 8.3ms single half sine-wave, duty cycle= 4 pulses per minutes maximum.
5. Peak pluse power waveformis 10/1000 μs .

Marking

Marking	HG
---------	----

P4SMAJ6.0A

Typical Characteristics

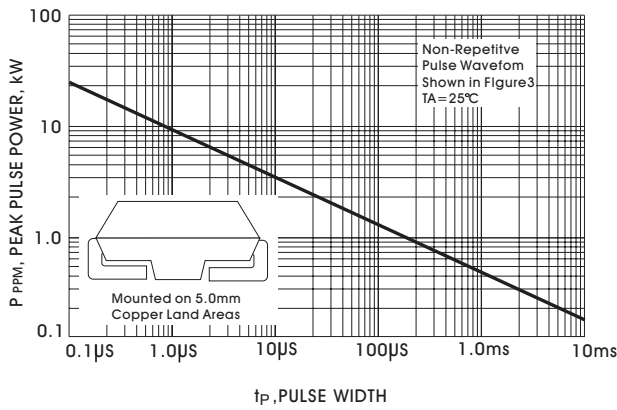

Figure 1, Peak Pulse Power Rating Curve

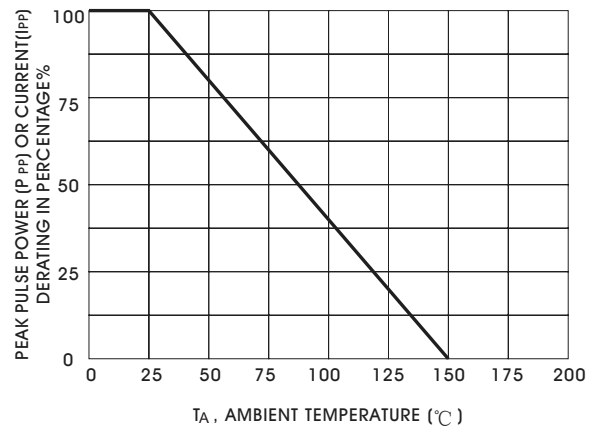

Figure 2, Derating Curve

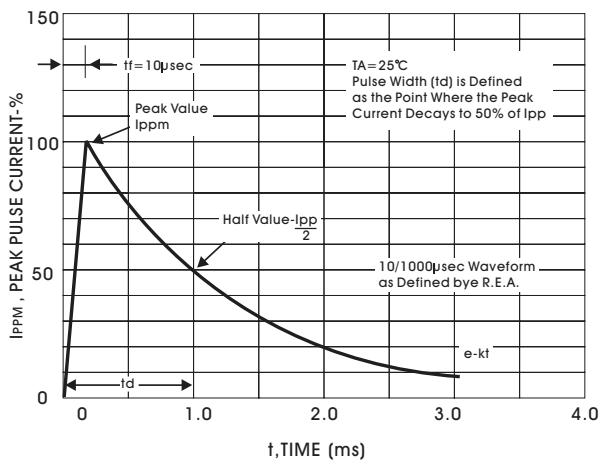

Figure 3, Pulse Waveform

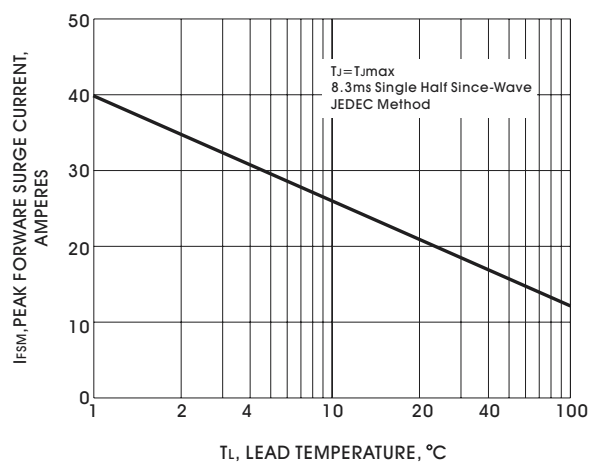

Figure 4, Maximum Non-Repetitive Peak Forward Surge Current

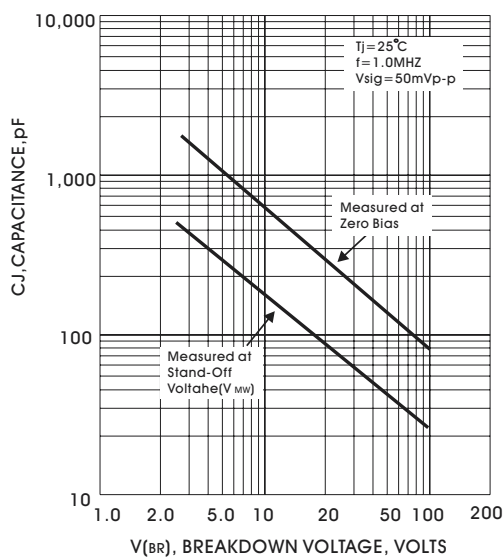

Figure 5, Typical Capacitance