

High Voltage NPN Transistor MMST5551

Features

- Ultra-Small Surface Mount Package
- Ideal for Medium Power Amplification and Switching
- Complementary PNP Type Available (MMST5401)

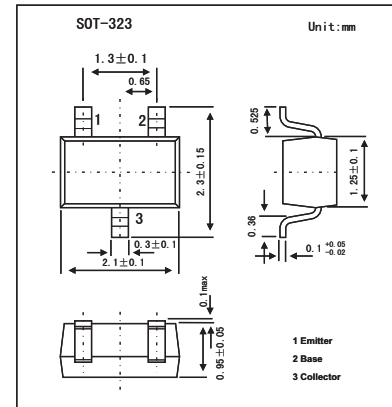

Absolute Maximum Ratings $T_a = 25^\circ\text{C}$

Parameter	Symbol	Rating	Unit
Collector-base voltage	V_{CB0}	180	V
Collector-emitter voltage	V_{CE0}	160	V
Emitter-base voltage	V_{EB0}	6	V
Collector current-continuous	I_C	0.6	A
Collector Power Dissipation	P_C	200	mW
Junction and storage temperature	T_J, T_{stg}	-55 to +150	$^\circ\text{C}$

Electrical Characteristics $T_a = 25^\circ\text{C}$

Parameter	Symbol	Test conditions	Min	Typ	Max	Unit
Collector-base breakdown voltage	$V_{(BR)CBO}$	$I_C = 100 \mu\text{A}, I_E = 0$	180			V
Collector-emitter breakdown voltage *	$V_{(BR)CEO}$	$I_C = 1.0 \text{ mA}, I_B = 0$	160			V
Emitter-base breakdown voltage	$V_{(BR)EBO}$	$I_E = 10 \mu\text{A}, I_C = 0$	6			V
Collector cutoff current	I_{CBO}	$V_{CB} = 120 \text{ V}, I_E = 0$			50	nA
Emitter cutoff current	I_{EBO}	$V_{EB} = 4.0 \text{ V}, I_C = 0$			50	nA
DC current gain	h_{FE}	$I_C = 1.0 \text{ mA}, V_{CE} = 5 \text{ V}$	80			
		$I_C = 10 \text{ mA}, V_{CE} = 5 \text{ V}$	100		300	
		$I_C = 50 \text{ mA}, V_{CE} = 5 \text{ V}$	30			
Collector-emitter saturation voltage	$V_{CE(sat)}$	$I_C = 10 \text{ mA}, I_B = 1.0 \text{ mA}$			0.15	V
		$I_C = 50 \text{ mA}, I_B = 5.0 \text{ mA}$			0.2	
Base-emitter saturation voltage	$V_{BE(sat)}$	$I_C = 10 \text{ mA}, I_B = 1.0 \text{ mA}$			1.0	V
		$I_C = 50 \text{ mA}, I_B = 5.0 \text{ mA}$			1.0	
Transistor frequency	f_T	$V_{CE}=10\text{V}, I_C=10\text{mA}, f=100\text{MHz}$	100		300	MHz
Collector output capacitance	C_{ob}	$V_{CB}=10\text{V}, I_E=0, f=1\text{MHz}$			6	pF
Input capacitance	C_{ib}	$V_{BE}=0.5\text{V}, I_C=0, f=1\text{MHz}$			20	pF
Noise figure	NF	$V_{CE}=5\text{V}, I_C=0.25\text{mA}, f=10\text{Hz to } 15.7\text{KHz}, R_s=1\text{k}\Omega$			8	dB

* Pulse Test: Pulse Width = 300 μs , Duty Cycle=2.0%.

Marking

Marking	K4N
---------	-----