

2.0W Surface Mount Complementary PNP Silicon Power Transistor KZT2955 (CZT2955)

■ Features

- High current (max. 6A).
- Low voltage (max. 60V).

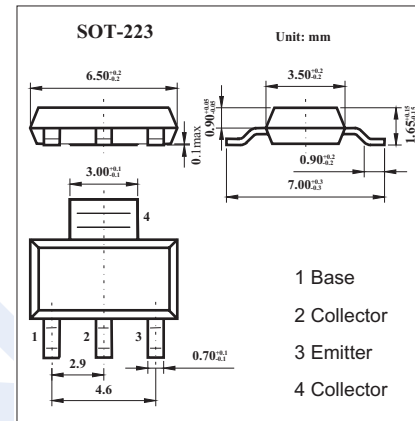

■ Absolute Maximum Ratings $T_a = 25^\circ\text{C}$

Parameter	Symbol	Rating	Unit
Collector-base voltage	V_{CBO}	-100	V
Collector - emitter voltage	V_{CER}	-70	V
Collector-emitter voltage	V_{CEO}	-60	V
Emitter-base voltage	V_{EBO}	-7	V
Collector current	I_C	-6	A
Base current	I_B	-3	A
Power dissipation	P_D	2	W
Thermal resistance, Junction-to-ambient	$R_{\theta JA}$	62.5	$^\circ\text{C/W}$
Junction temperature	T_j	150	$^\circ\text{C}$
Storage temperature	T_{stg}	-65 to +150	$^\circ\text{C}$

■ Electrical Characteristics $T_a = 25^\circ\text{C}$

Parameter	Symbol	Test conditions	Min	Typ	Max	Unit
Collector to emitter breakdown voltage	V_{CEO}	$I_C = -30\text{mA}$	-60			V
Collector to emitter breakdown voltage	V_{CER}	$I_C = -30\text{mA}, R_{BE} = 100\ \Omega$	-70			V
Collector cutoff current	I_{CEO}	$V_{CE} = -30\text{V}$			-700	μA
	I_{CEV}	$V_{CE} = -100\text{V}, V_{EB} = -1.5\text{V}$			1.0	mA
Emitter cutoff current	I_{EBO}	$V_{EB} = -7.0\text{V}$			-5.0	mA
DC current gain	h_{FE}	$I_C = -4.0\text{A}; V_{CE} = -4.0\text{V}$	20		70	
		$I_C = -6.0\text{A}; V_{CE} = -4.0\text{V}$	5.0			
Collector to emitter saturation voltage	$V_{CE(sat)}$	$I_C = -4.0\text{A}; I_B = -400\text{mA}$			-1.1	V
Base to emitter ON voltage	$V_{BE(on)}$	$V_{CE} = -4.0\text{V}, I_C = -4.0\text{A}$			-1.5	V
Transition frequency	f_T	$I_C = -500\text{mA}; V_{CE} = -10\text{V}; f = 1.0\text{MHz}$	2.5			MHz