

## Silicon Epitaxial Planar Pin Diode

## HVC145

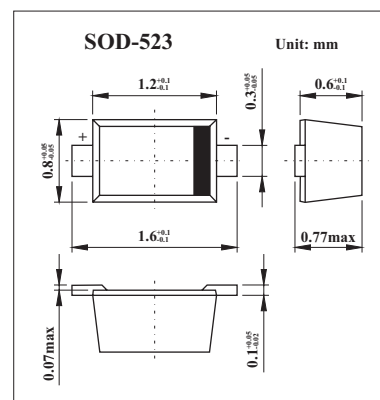

### ■ Features

- An optimal solution for antenna switching in mobile phones.
- Low capacitance. ( $C = 0.45 \text{ pF max}$ )
- Low forward resistance. ( $r_f = 1.8 \ \Omega \text{ max}$ )

### ■ Absolute Maximum Ratings $T_a = 25^\circ\text{C}$

Parameter	Symbol	Value	Unit
Reverse voltage	$V_R$	60	V
Forward current	$I_F$	50	mA
Power dissipation	$P_d$	150	mW
Junction temperature	$T_j$	125	$^\circ\text{C}$
Storage temperature	$T_{\text{stg}}$	-55 to +125	$^\circ\text{C}$

### ■ Electrical Characteristics $T_a = 25^\circ\text{C}$

Parameter	Symbol	Conditions	Min	Typ	Max	Unit
Reverse current	$I_R$	$V_R = 60 \text{ V}$			100	nA
Reverse voltage	$V_F$	$I_F = 2 \text{ mA}$			0.9	V
Capacitance	$C$	$V_R = 1 \text{ V}, f = 1 \text{ MHz}$			0.45	pF
Forward resistance	$r_f$	$I_F = 10 \text{ mA}, f = 100 \text{ MHz}$			1.8	$\Omega$
ESD-Capability *1		$C = 200\text{pF}$ , Both forward and reverse direction 1 pulse	100			V

Note

1. Failure criterion ;  $I_R > 100 \text{ nA}$  at  $V_R = 60\text{V}$ .

### ■ Marking

Marking	T5
---------	----