

PNP Silicon Planar Medium Power Transistor

FZT549

Features

Power Collector dissipation: $P_c=2W$

Continuous Collector Current: $I_c=-1A$

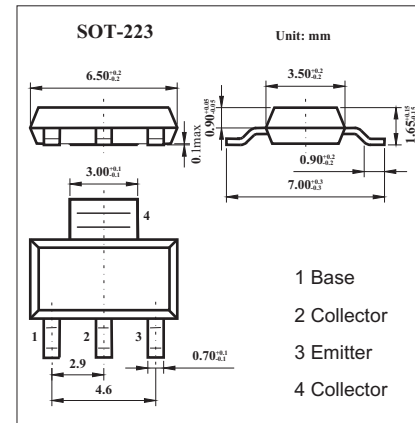

Absolute Maximum Ratings $T_a = 25^\circ C$

Parameter	Symbol	Rating	Unit
Collector-base voltage	V_{CBO}	-35	V
Collector-emitter voltage	V_{CEO}	-30	V
Emitter-base voltage	V_{EBO}	-5	V
Continuous Collector Current	I_c	-1	A
Peak collector current	I_{CM}	-2	A
Power Collector dissipation	P_c	2	W
Operating and storage temperature range	T_j, T_{stg}	-55 to +150	$^\circ C$

Electrical Characteristics $T_a = 25^\circ C$

Parameter	Symbol	Test conditons	Min	Typ	Max	Unit
Collector-base breakdown voltage	$V_{(BR)CBO}$	$I_c=-100\mu A$	-35			V
Collector-emitter breakdown voltage *	$V_{(BR)CEO}$	$I_c=-10mA$	-30			V
Emitter-base breakdown voltage	$V_{(BR)EBO}$	$I_E=-100\mu A$	-5			V
Collector cutoff current	I_{CBO}	$V_{CB}=-30V$			-100	nA
Emitter cut-off current	I_{EBO}	$V_{EB}=-4V, I_c=0$			-100	nA
Collector-emitter saturation voltage *	$V_{CE(sat)}$	$I_c=-1A, I_B=-100mA$			-0.5	V
Base-emitter saturation voltage *	$V_{BE(sat)}$	$I_c=-1A, I_B=-100mA$			-1.25	V
Base-emitter voltage *	$V_{BE(ON)}$	$I_c=-1A, V_{CE}=-2V$			-1.0	V
DC current gain	h_{FE}	$I_c=-50mA, V_{CE}=-2V^*$	70			
		$I_c=-500mA, V_{CE}=-2V$	100		300	
		$I_c=-1A, V_{CE}=-2V^*$	80			
		$I_c=-2A, V_{CE}=-2V^*$	30			
Transition frequency	f_T	$I_c=-100mA, V_{CE}=-5V, f=100MHz$	100			MHz
Output capacitance	C_{ob}	$V_{CB}=-10V, f=1MHz$			10	pF

* Pulse test: $t_p = 300 \mu s$; $d = 0.02$.

Marking

Marking	549
---------	-----