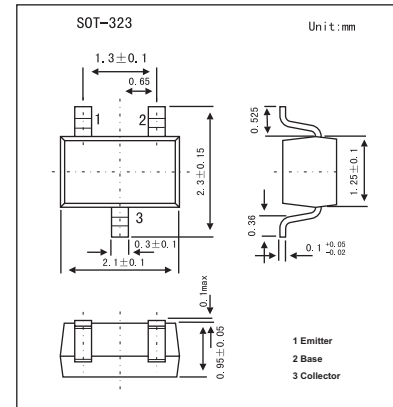

PNP Medium Frequency Transistor

BF824W

■ Features

- Low current (max. 25 mA).
- Low voltage (max. 30 V).

■ Absolute Maximum Ratings $T_a = 25^\circ\text{C}$

Parameter	Symbol	Rating	Unit
Collector-base voltage	V_{CB0}	-30	V
Collector-emitter voltage	V_{CEO}	-30	V
Emitter-base voltage	V_{EBO}	-4	V
Collector current	I_C	-25	mA
Peak collector current	I_{CM}	-25	mA
Total power dissipation *	P_{tot}	200	mW
Storage temperature	T_{stg}	-65 to +150	$^\circ\text{C}$
Junction temperature	T_j	150	$^\circ\text{C}$
Operating ambient temperature	R_{amb}	-65 to +150	$^\circ\text{C}$
Thermal resistance from junction to ambient *	$R_{th\ j-a}$	625	K/W

* Transistor mounted on an FR4 printed-circuit board.

■ Electrical Characteristics $T_a = 25^\circ\text{C}$

Parameter	Symbol	Testconditions	Min	Typ	Max	Unit	
Collector cutoff current	I_{CBO}	$I_E = 0; V_{CB} = -30\text{ V}$			-50	nA	
		$I_E = 0; V_{CB} = -30\text{ V}; T_j = 150\text{ }^\circ\text{C}$			-10	μA	
Emitter cutoff current	I_{EBO}	$I_C = 0; V_{EB} = -4\text{ V}$			-100	nA	
DC current gain	h_{FE}	$I_C = -1\text{ mA}; V_{CE} = -10\text{ V}$	25				
		$I_C = -4\text{ mA}; V_{CE} = -10\text{ V}$	25				
Base to emitter voltage	V_{BE}	$I_C = -4\text{ mA}; V_{CE} = -10\text{ V}$			-900	mV	
Feedback capacitance	C_{rb}	$I_C = 0; V_{CE} = -10\text{ V}; f = 1\text{ MHz}$			0.3	pF	
Transition frequency	f_t	$V_{CE} = -10\text{ V}; f = 100\text{ MHz};$	250			MHz	
		$I_C = -1\text{ mA}$	400				
		$I_C = -4\text{ mA}$					
		$I_C = -8\text{ mA}$	390				

■ Marking

Marking	F8
---------	----