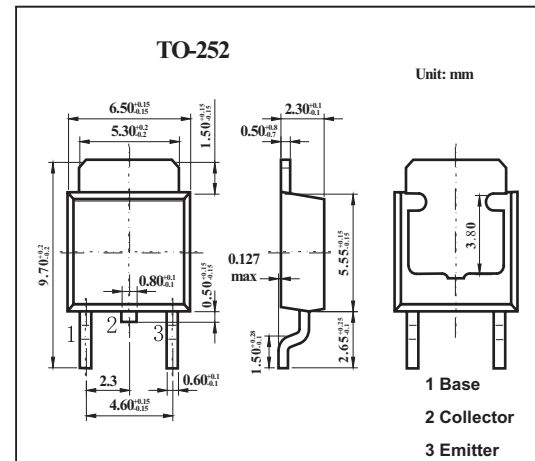

## Silicon NPN Triple Diffusion Planar Type

## 2SD1249, 2SD1249A

## ■ Features

- High collector-base voltage (Emitter open)  $V_{CB0}$

■ Absolute Maximum Ratings  $T_a = 25^\circ\text{C}$ 

Parameter	Symbol	Rating	Unit
Collector-base voltage (Emitter open)	$V_{CB0}$	2SD1249 350	V
		2SD1249A 400	V
Collector-emitter voltage (Base open)	$V_{CEO}$	2SD1249 250	V
		2SD1249A 300	V
Emitter-base voltage (Collector open)	$V_{EBO}$	5	V
Collector current	$I_C$	0.75	A
Peak collector current	$I_{CP}$	1.5	A
Collector power dissipation $T_a = 25^\circ\text{C}$	$P_C$	35	W
		1.3	
Junction temperature	$T_j$	150	$^\circ\text{C}$
Storage temperature	$T_{stg}$	-55 to +150	$^\circ\text{C}$

**2SD1249, 2SD1249A**

## ■ Electrical Characteristics Ta = 25°C

Parameter	Symbol	Testconditons	Min	Typ	Max	Unit
Collector-emitter voltage (Base open)	V <sub>CEO</sub>	I <sub>c</sub> = 30 mA, I <sub>B</sub> = 0	250			V
			300			V
Collector-emitter cutoff current (E-B short)	I <sub>CES</sub>	V <sub>CE</sub> = 350 V, V <sub>BE</sub> = 0			1	mA
		V <sub>CE</sub> = 400 V, V <sub>BE</sub> = 0			1	mA
Collector-emitter cutoff current (Base open)	I <sub>CEO</sub>	V <sub>CE</sub> = 150 V, I <sub>B</sub> = 0			1	mA
		V <sub>CE</sub> = 200 V, I <sub>B</sub> = 0			1	mA
Emitter-base cutoff current (Collector open)	I <sub>EBO</sub>	V <sub>EB</sub> = 5 V, I <sub>C</sub> = 0			1	mA
Forward current transfer ratio	h <sub>FE</sub>	V <sub>CE</sub> = 10 V, I <sub>c</sub> = 0.3 A	40		250	
		V <sub>CE</sub> = 10 V, I <sub>c</sub> = 1 A	10			
Base-emitter voltage	V <sub>BE</sub>	V <sub>CE</sub> = 10 V, I <sub>c</sub> = 1 A			1.5	V
Collector-emitter saturation voltage	V <sub>CE(sat)</sub>	I <sub>c</sub> = 1 A, I <sub>B</sub> = 0.2 A			1.0	V
Transition frequency	f <sub>T</sub>	V <sub>CE</sub> = 10 V, I <sub>c</sub> = 0.2 A, f = 10 MHz		30		MHz
Turn-on time	t <sub>on</sub>	I <sub>c</sub> = 1 A		0.5		μs
Strage time	t <sub>stg</sub>	I <sub>B1</sub> = 0.1 A, I <sub>B2</sub> = ? 0.1 A		2.0		μs
Fall time	t <sub>f</sub>	V <sub>CC</sub> = 50 V		0.5		μs

## ■ hFE Classification

Rank	R	Q	P
hFE	40 to 90	70 to 150	120 to 250