

Silicon NPN triple diffusion planar type

2SC5457

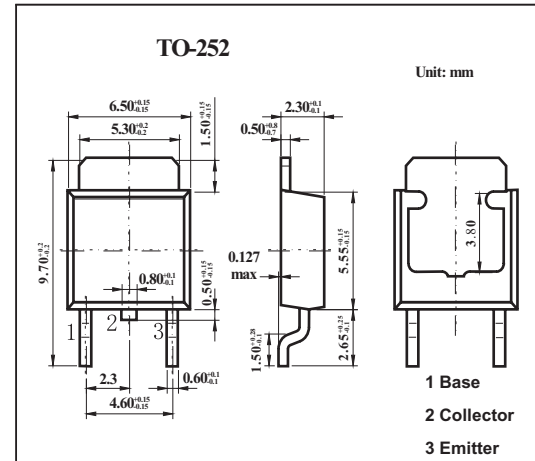

■ Features

- High-speed switching
- High collector to base voltage V_{CB0}
- Wide area of safe operation (ASO)
- Satisfactory linearity of forward current transfer ratio h_{FE}

■ Absolute Maximum Ratings $T_a = 25^\circ\text{C}$

Parameter	Symbol	Rating	Unit
Collector to base voltage	V_{CB0}	500	V
Collector to emitter voltage	V_{CES}	500	V
	V_{CEO}	400	V
Emitter to base voltage	V_{EBO}	7	V
Peak collector current	I_{CP}	6	A
Collector current	I_C	3	A
Base current	I_B	1.2	A
Collector power dissipation $T_c = 25^\circ\text{C}$ $T_a = 25^\circ\text{C}$	P_C	30	W
		1	
Junction temperature	T_j	150	$^\circ\text{C}$
Storage temperature	T_{stg}	-55 to +150	$^\circ\text{C}$

■ Electrical Characteristics $T_a = 25^\circ\text{C}$

Parameter	Symbol	Test conditions	Min	Typ	Max	Unit
Collector cutoff current	I_{CBO}	$V_{CB} = 500\text{V}, I_E = 0$			100	μA
Emitter cutoff current	I_{EBO}	$V_{EB} = 5\text{V}, I_C = 0$			100	μA
Collector to emitter voltage	V_{CEO}	$I_C = 10\text{mA}, I_B = 0$	400			V
Forward current transfer ratio	h_{FE}	$V_{CE} = 5\text{V}, I_C = 0.1\text{A}$	10			V
		$V_{CE} = 2\text{V}, I_C = 1.2\text{A}$	8		40	
Collector to emitter saturation voltage	$V_{CE(sat)}$	$I_C = 1.5\text{A}, I_B = 0.3\text{A}$			1	
Base to emitter saturation voltage	$V_{BE(sat)}$	$I_C = 1.5\text{A}, I_B = 0.3\text{A}$			1.5	V
Transition frequency	f_T	$V_{CE} = 10\text{V}, I_C = 0.2\text{A}, f = 1\text{MHz}$		10		MHz
Turn-on time	t_{on}	$I_C = 1.5\text{A}, I_{B1} = 0.15\text{A}, I_{B2} = -0.3\text{A},$ $V_{CC} = 200\text{V}$			1.0	μs
Storage time	t_{stg}				3.0	
Fall time	t_f				0.3	