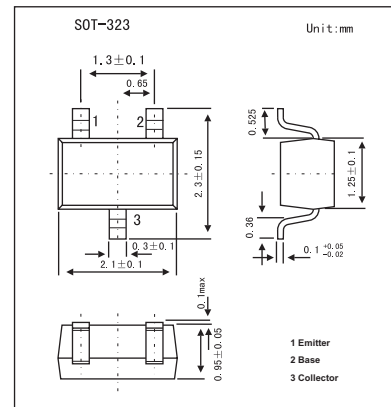

## NPN Epitaxial Planar Silicon Transistor

## 2SC4446

## ■ Features

- Very small-sized package
- High VEBO.

■ Absolute Maximum Ratings  $T_a = 25^\circ\text{C}$ 

Parameter	Symbol	Rating	Unit
Collector-base voltage	$V_{CB0}$	60	V
Collector-emitter voltage	$V_{CE0}$	50	V
Emitter-base voltage	$V_{EBO}$	15	V
Collector current	$I_C$	150	mA
Collector current(Pulse)	$I_{CP}$	300	mA
Base current	$I_B$	30	mA
Collector dissipation	$P_C$	150	mW
Junction temperature	$T_j$	150	$^\circ\text{C}$
Storage temperature	$T_{stg}$	-55 to +150	$^\circ\text{C}$

## 2SC4446

## ■ Electrical Characteristics Ta = 25°C

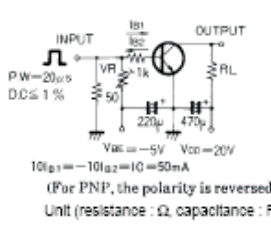
Parameter	Symbol	Testconditions	Min	Typ	Max	Unit	
Collector cutoff current	IcBO	V <sub>CB</sub> = 40V, I <sub>E</sub> =0			0.1	μA	
Emitter cutoff current	I <sub>E</sub> BO	V <sub>EB</sub> = 10V, I <sub>C</sub> =0			0.1	μA	
DC current gain	h <sub>FE</sub>	V <sub>CE</sub> = 6V, I <sub>C</sub> = 1mA	135		600		
Gain bandwidth product	f <sub>T</sub>	V <sub>CE</sub> = 6V, I <sub>C</sub> = 1mA		130		MHz	
Collector-to-emitter saturation voltage	V <sub>CE(sat)</sub>	I <sub>C</sub> = 50mA, I <sub>B</sub> = 5mA		0.15	0.5	V	
Base-to-emitter saturation voltage	V <sub>BE(sat)</sub>	I <sub>C</sub> = 50mA, I <sub>B</sub> = 5mA		0.85	1.2	V	
Collector-to-base breakdown voltage	V <sub>(BR)CBO</sub>	I <sub>C</sub> = 10μA, I <sub>E</sub> = 0	60			V	
Collector-to-emitter breakdown voltage	V <sub>(BR)CEO</sub>	I <sub>C</sub> = 1mA, R <sub>BE</sub> = ∞	50			V	
Emitter-to-base breakdown voltage	V <sub>(BR)EBO</sub>	I <sub>E</sub> = 10μA, I <sub>C</sub> = 0	15			V	
Output capacitance	C <sub>ob</sub>	V <sub>CB</sub> = 6V, f = 1MHz		2.2		pF	
Turn-on time	ton	 <p>           INPUT <math>PW=20\mu s</math>  <math>DC \leq 1\%</math>  <math>V_{BE} = -5V</math> <math>V_{CE} = 20V</math>  <math>10I_{B1} = -10I_{B2} = I_C = 50mA</math>            (For PNP, the polarity is reversed.)            Unit (resistance : <math>\Omega</math>, capacitance : F)         </p>		50		ns	
Storage time	tstg				590		ns
Fall time	tf				110		ns

## ■ hFE Classification

Marking	H		
Rank	5	6	7
hFE	135~270	200~400	300~600