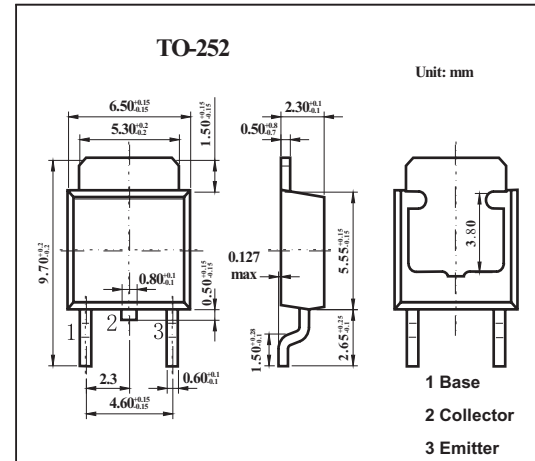

## Silicon PNP Epitaxial Planar Type

## 2SB935

## ■ Features

- Low collector-emitter saturation voltage  $V_{CE(sat)}$ .
- High-speed switching.

■ Absolute Maximum Ratings  $T_a = 25^\circ\text{C}$ 

| Parameter                   | Symbol    | Rating      | Unit             |
|-----------------------------|-----------|-------------|------------------|
| Collector-base voltage      | $V_{CB0}$ | -40         | V                |
| Collector-emitter voltage   | $V_{CEO}$ | -20         | V                |
| Emitter-base voltage        | $V_{EB0}$ | -5          | V                |
| Collector current           | $I_C$     | -10         | A                |
| Peak collector current      | $I_{CP}$  | -15         | A                |
| Collector power dissipation | $P_C$     | 1.3         | W                |
| Junction temperature        | $T_j$     | 150         | $^\circ\text{C}$ |
| Storage temperature         | $T_{stg}$ | -55 to +150 | $^\circ\text{C}$ |

■ Electrical Characteristics  $T_a = 25^\circ\text{C}$ 

| Parameter                            | Symbol        | Testconditions   | Min | Typ | Max  | Unit          |
|--------------------------------------|---------------|--|-----|-----|------|---------------|
| Collector-base cutoff current        | $I_{CB0}$     | $V_{CB} = -40\text{ V}, I_E = 0$                                   |     |     | -50  | $\mu\text{A}$ |
| Emitter-base cutoff current          | $I_{EB0}$     | $V_{EB} = -5\text{ V}, I_C = 0$                                    |     |     | -50  | $\mu\text{A}$ |
| Collector-emitter voltage            | $V_{CEO}$     | $I_C = -10\text{ mA}, I_B = 0$                                     | -20 |     |      | V             |
| Forward current transfer ratio       | $h_{FE}$      | $V_{CE} = -2\text{ V}, I_C = -2\text{ A}$                          | 90  |     | 260  | V             |
|                                      |               | $V_{CE} = -2\text{ V}, I_C = -0.1\text{ A}$                        | 45  |     |      |               |
| Collector-emitter saturation voltage | $V_{CE(sat)}$ | $I_C = -7\text{ A}, I_B = -0.23\text{ A}$                          |     |     | -1.5 | V             |
| Base-emitter saturation voltage      | $V_{BE(sat)}$ | $I_C = -7\text{ A}, I_B = -0.23\text{ A}$                          |     |     | -0.6 | V             |
| Transition frequency                 | $f_T$         | $V_{CE} = -10\text{ V}, I_E = -0.5\text{ A}, f = 10\text{ MHz}$    |     | 150 |      | MHz           |
| Collector output capacitance         | $C_{ob}$      | $V_{CB} = -10\text{ V}, I_E = 0, f = 1.0\text{ MHz}$               |     | 200 |      | pF            |
| Turn-on time                         | $t_{on}$      | $I_C = -2\text{ A}, I_{B1} = -66\text{ mA}, I_{B2} = 66\text{ mA}$ |     | 0.1 |      | $\mu\text{s}$ |
| Storage time                         | $t_{stg}$     |  |     | 0.5 |      | $\mu\text{s}$ |
| Fall time                            | $t_f$         |  |     |     | 0.1  | $\mu\text{s}$ |

■  $h_{FE}$  Classification

| Rank     | Q      | P       |
|----------|--------|---------|
| $h_{FE}$ | 90~180 | 130~260 |