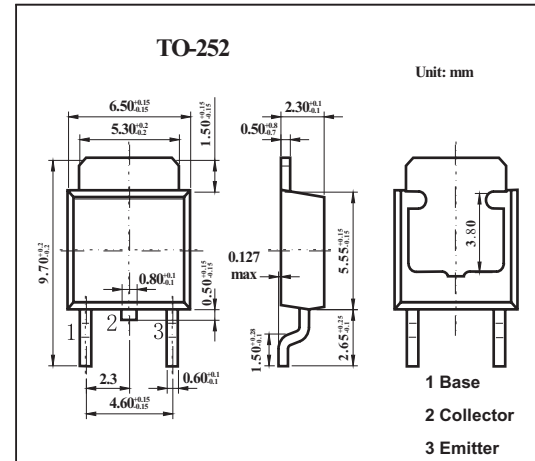

Silicon PNP Epitaxial Planar Type

2SB929

■ Features

- High forward current transfer ratio h_{FE} which has satisfactory linearity.
- Low collector-emitter saturation voltage $V_{CE(sat)}$.

■ Absolute Maximum Ratings $T_a = 25^\circ\text{C}$

Parameter	Symbol	Rating	Unit
Collector-base voltage	V_{CBO}	-60	V
Collector-emitter voltage	V_{CEO}	-60	V
Emitter-base voltage	V_{EBO}	-5	V
Collector current	I_C	-3	A
Peak collector current	I_{CP}	-5	A
Collector power dissipation	P_C	1.3	W
Junction temperature	T_j	150	$^\circ\text{C}$
Storage temperature	T_{stg}	-55 to +150	$^\circ\text{C}$

■ Electrical Characteristics $T_a = 25^\circ\text{C}$

Parameter	Symbol	Testconditions	Min	Typ	Max	Unit
Collector cutoff current	I_{CES}	$V_{CE} = -60\text{ V}, V_{BE} = 0$			-200	μA
	I_{CEO}	$V_{CE} = -30\text{ V}, I_B = 0$			-300	μA
Emitter-base cutoff current	I_{EBO}	$V_{EB} = -5\text{ V}, I_C = 0$			-1	mA
Collector-emitter voltage	V_{CEO}	$I_C = -30\text{ mA}, I_B = 0$	-60			V
Forward current transfer ratio	h_{FE}	$V_{CE} = -4\text{ V}, I_C = -1\text{ A}$	70		250	
		$V_{CE} = -4\text{ V}, I_C = -3\text{ A}$	10			
Base to emitter voltage	V_{BE}	$V_{CE} = -4\text{ V}, I_C = -3\text{ A}$			-1.8	V
Collector-emitter saturation voltage	$V_{CE(sat)}$	$I_C = -3\text{ A}, I_B = -0.375\text{ A}$			-1.2	V
Transition frequency	f_T	$V_{CE} = -10\text{ V}, I_C = -0.5\text{ A}, f = 10\text{ MHz}$		30		MHz
Turn-on time	t_{on}	$I_C = -1\text{ A}, I_{B1} = -0.1\text{ A}, I_{B2} = 0.1\text{ A}$		0.5		μs
Storage time	t_{stg}			1.2		μs
Fall time	t_f			0.3		μs

■ h_{FE} Classification

Rank	Q	P
h_{FE}	70~150	120~250