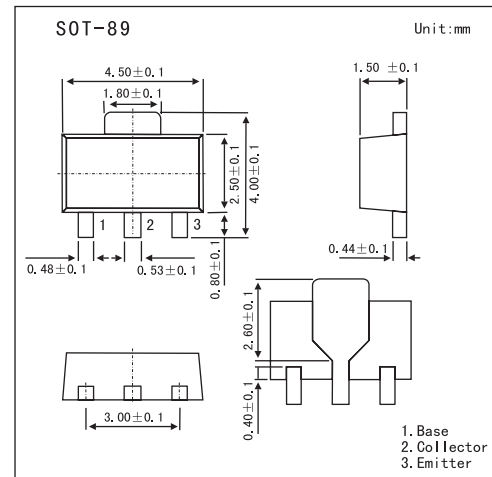

PNP Epitaxial Planar Silicon Transistors

2SB1121

■ Features

- Adoption of FBET, MBIT processes.
- Low collector-to-emitter saturation voltage.
- Large current capacity and wide ASO.
- Fast switching speed.
- Very small size making it easy to provide highdensity, small-sized hybrid IC's.

■ Absolute Maximum Ratings $T_a = 25^\circ\text{C}$

Parameter	Symbol	Rating	Unit
Collector-base voltage	V_{CB0}	-30	V
Collector-emitter voltage	V_{CE0}	-25	V
Emitter-base voltage	V_{EB0}	-6	V
Collector current	I_C	-2	A
Collector current (pulse)	I_{CP}	-5	A
Collector dissipation	P_C	500	mW
Junction temperature	T_J	150	$^\circ\text{C}$
Storage temperature	T_{stg}	-55 to +150	$^\circ\text{C}$

2SB1121

■ Electrical Characteristics Ta = 25°C

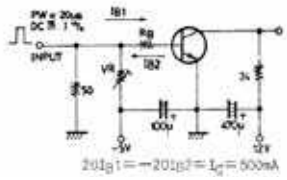
Parameter	Symbol	Testconditions	Min	Typ	Max	Unit
Collector cutoff current	ICBO	V _{CB} = -20V , I _E = 0			-0.1	μA
Emitter cutoff current	IEBO	V _{CB} = -4V , I _E = 0			-0.1	μA
DC current Gain	hFE	V _{CE} = -2V , I _C = -100mA	100		560	
Gain bandwidth product	f _T	V _{CE} = -10V , I _C = -50mA		150		MHz
Collector-emitter saturation voltage	V _{CE(sat)}	I _C = -1.5A , I _B = -75mA		-0.35	-0.6	V
Base-emitter saturation voltage	V _{BE(sat)}	I _C = -1.5A , I _B = -75mA		-0.85	-1.2	V
Collector-base breakdown voltage	V _{(BR)CBO}	I _C = -10μA , I _E = 0	-30			V
Collector-emitter breakdown voltage	V _{(BR)CEO}	I _C = -1mA , R _{BE} = ∞	-25			V
Emitter-base breakdown voltage	V _{(BR)EBO}	I _E = -10μA , I _C = 0	-6			V
Output capacitance	C _{ob}	V _{CB} = -10V , f = 1MHz		32		pF
Turn-on time	t _{on}	Switching Time Test Circuit 	60		ns	
Storage time	t _{stg}			350		ns
Fall time	t _f			25		ns

■ hFE Classification

Marking	BC		
	E	F	G
hFE	100~200	160~320	280~560