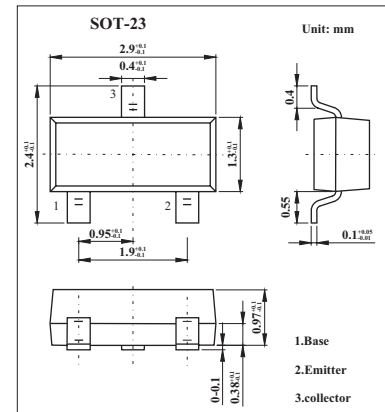

Silicon PNP Epitaxial Type

2SA2058

■ Features

- High DC current gain: $h_{FE} = 200$ to 500 ($I_C = \pm 0.2$ A)
- Low collector-emitter saturation voltage: $V_{CE(sat)} = \pm 0.19$ V (max)
- High-speed switching: $t_f = 25$ ns (typ.)

■ Absolute Maximum Ratings $T_a = 25^\circ\text{C}$

Parameter	Symbol	Rating	Unit
Collector-base voltage	V_{CB0}	-20	V
Collector-emitter voltage	V_{CE0}	-10	V
Emitter-base voltage	V_{EB0}	-7	V
Collector current (DC)	I_C	-1.5	A
Collector current (Pulse)	I_{cp}	-2.5	A
Base current	I_B	-150	mA
Collector power dissipation DC	P_C	500	mW
Collector power dissipation $t=10s$ *	P_C	750	mW
Jumction temperature	T_j	150	$^\circ\text{C}$
Storage temperature	T_{stg}	-55 to +150	$^\circ\text{C}$

* Mounted on FR4 board (glass epoxy, 1.6 mm thick, Cu area:645 mm²)

2SA2058

■ Electrical Characteristics $T_a = 25^\circ\text{C}$

Parameter	Symbol	Testconditions	Min	Typ	Max	Unit
Collector cutoff current	I_{CBO}	$V_{CB} = -20V, I_E = 0$			-100	nA
Emitter cutoff current	I_{EBO}	$V_{EB} = -7V, I_C = 0$			-100	nA
Collector-to-emitter breakdown voltage	$V_{(BR)CEO}$	$I_C = -10mA, I_B = 0$	-10			V
DC current Gain	h_{FE}	$V_{CE} = -2V, I_C = -0.2A$	200		500	
		$V_{CE} = -2V, I_C = -0.6A$	125			
Collector-emitter saturation voltage	$V_{CE(sat)}$	$I_C = -0.6A, I_B = -20mA$			-0.19	V
Base-emitter saturation voltage	$V_{BE(sat)}$	$I_C = -0.6A, I_B = -20mA$			-1.10	V
Collector output capacitance	C_{ob}	$V_{CB} = -10V, I_E = 0, f = 1MHz$		12		pF
Switching time Rise time	t_{on}	$V_{CC} = -6V, R_L = 10\Omega, -I_{B1} = I_{B2} = -20mA$ see Figure 1		50		ns
Switching time Storage time	t_{stg}			115		ns
Switching time Fall time	t_f			25		ns

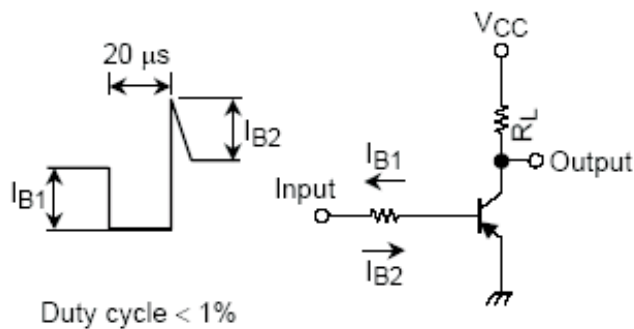

Figure 1: Switching Time Test Circuit & Timing Chart

■ Marking

Marking	W M
---------	-----