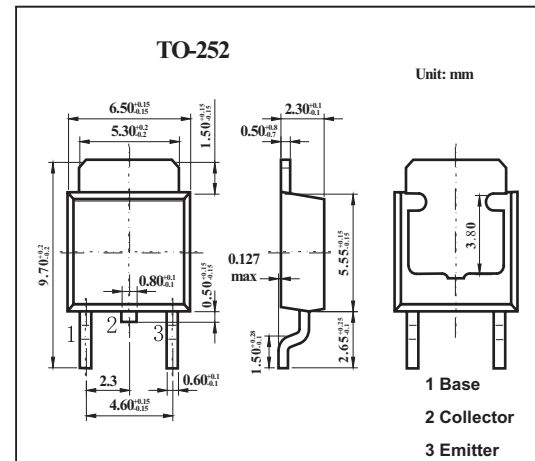

PNP Epitaxial Planar Silicon Transistor

2SA1773

■ Features

- High breakdown voltage
- Large current capacity ($I_c=2A$)

■ Absolute Maximum Ratings $T_a = 25^\circ\text{C}$

Parameter	Symbol	Rating	Unit
Collector to Base Voltage	V_{CBO}	-400	V
Collector to Emitter Voltage	V_{CEO}	-400	V
Emitter to Base Voltage	V_{EBO}	-5	V
Collector Current (DC)	I_c	-2	A
Collector Current (Pulse)	I_C	-4	A
Collector Dissipation $T_c=25^\circ\text{C}$	P_c	1	W
		15	W
Junction Temperature	T_j	150	$^\circ\text{C}$
Storage Temperature	T_{stg}	-55 to 150	$^\circ\text{C}$

2SA1773

■ Electrical Characteristics Ta = 25°C

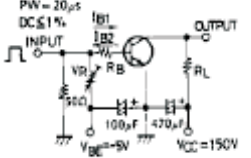
Parameter	Symbol	Testconditons	Min	Typ	Max	Unit	
Collector Cutoff Current	I _{CBO}	V _{CB} =-300V, I _E =0			-0.1	μA	
Emitter Cutoff Current	I _{EBO}	V _{EB} =-4V, I _C =0			-0.1	μA	
DC Current Gain*	h _{FE}	V _{CE} =-10V, I _C =-100mA	40		200		
Gain- Bandwidth Product	f _T	V _{CE} =-10V, I _C =-50mA		40		MHz	
C-E Saturation Voltage	V _{CE(sat)}	I _C =-500mA, I _B =-50mA			-1.0	V	
B-E Saturation Voltage	V _{BE(sat)}	I _C =-500mA, I _B =-50mA			-1.0	V	
C-B Breakdown Voltage	V _{(BR)CBO}	I _C =-10μA, I _E =0	-400			V	
C-E Breakdown Voltage	V _{(BR)CEO}	I _C =-1mA, R _{BE} =∞	-400			V	
E-B Breakdown Voltage	V _{(BR)EBO}	I _E =-10μA, I _C =0	-5			V	
Output Capacitance	C _{ob}	V _{CB} =-30V, f=1MHz		25		pF	
Turn-ON Time	t _{on}	 <p> $PW = 20\mu s$ $DC \leq 1\%$ $10I_{B1} = -10I_{B2} = I_C = 500mA$ $R_C = 300\Omega, R_E = 20\Omega, \text{ at } I_C = 500mA$ (For PNP, the polarity is reversed.) </p>		0.12		μs	
Storage Time	t _{stg}				3		
Fall Time	t _f				0.3		

■ hFE Classification

Rank	C	D	E
hFE	40 to 80	60 to 120	100 to 200