

## High-Voltage Switching Applications

## 2SA1416

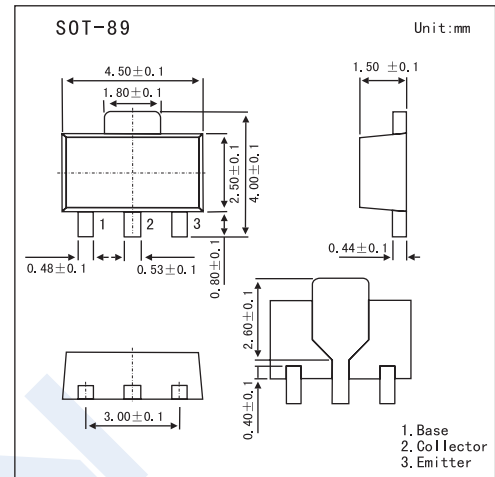

### Features

- Adoption of FBET, MBIT Processes
- High Breakdown Voltage and Large Current Capacity
- Fast Switching Time

### Absolute Maximum Ratings $T_a = 25^\circ\text{C}$

Parameter	Symbol	Rating	Unit
Collector-Base Voltage	$V_{CB0}$	-120	V
Collector-Emitter Voltage	$V_{CE0}$	-100	V
Emitter-Base Voltage	$V_{EB0}$	-6	V
Collector Current	$I_C$	-1	A
Collector Current (Pulse)	$I_{CP}$	-2	A
Collector Power Dissipation	$P_C$	500	mW
	$P_{C^*}$	1.3	W
Junction temperature	$T_j$	150	$^\circ\text{C}$
Storage temperature Range	$T_{stg}$	-55 to +150	$^\circ\text{C}$

\* Mounted on ceramic board (250 mm<sup>2</sup> x 0.8 mm)

### Electrical Characteristics $T_a = 25^\circ\text{C}$

Parameter	Symbol	Testconditions	Min	Typ	Max	Unit
Collector Cut-off Current	$I_{CBO}$	$V_{CB} = -100\text{V}$ , $I_E = 0$			-100	nA
Emitter Cut-off Current	$I_{EBO}$	$V_{EB} = -4\text{V}$ , $I_C = 0$			-100	nA
Collector-Base Breakdown Voltage	$V_{(BR)CBO}$	$I_C = -10\mu\text{A}$ , $I_E = 0$	-120			V
Collector-Emitter Breakdown Voltage	$V_{(BR)CEO}$	$I_C = -1\text{mA}$ , $R_{BE} = \infty$	-100			V
Emitter-Base Breakdown Voltage	$V_{(BR)EBO}$	$I_E = -10\mu\text{A}$ , $I_C = 0$	-6			V
DC Current Gain	$h_{FE}$	$V_{CE} = -5\text{V}$ , $I_C = -100\text{mA}$	100		400	
Collector-Emitter Saturation Voltage	$V_{CE(sat)}$	$I_C = -400\text{mA}$ , $I_B = -40\text{mA}$		-0.2	-0.6	V
Base-Emitter Saturation Voltage	$V_{BE(sat)}$	$I_C = -400\text{mA}$ , $I_B = -40\text{mA}$		-0.85	-1.2	V
Gain-Bandwidth Product	$f_T$	$V_{CE} = -10\text{V}$ , $I_C = -100\text{mA}$		120		MHz
Collector Output Capacitance	$C_{ob}$	$V_{CB} = -10\text{V}$ , $I_E = 0$ , $f = 1\text{MHz}$		13		pF
Turn-On Time	$t_{on}$	See Test Circuit.		80		ns
Storage Time	$t_{stg}$			700		
Fall Time	$t_f$			40		

## 2SA1416

### Test Circuit

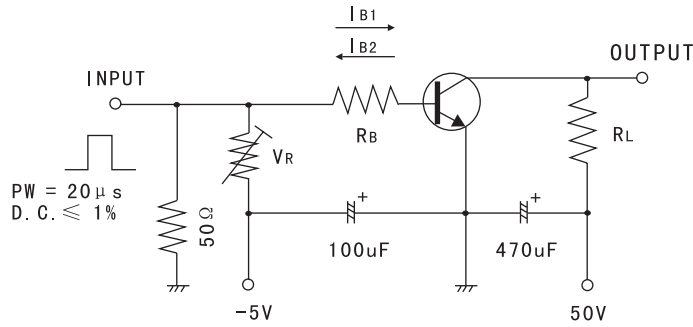

$10I_{B1} = -10I_{B2} = I_C = 400\text{mA}$   
 (For PNP, the polarity is reversed.)

### hFE Classification

Marking	AB		
Rank	R	S	T
hFE	100 ~ 200	140 ~ 280	200 ~ 400

### Electrical Characteristics Curves

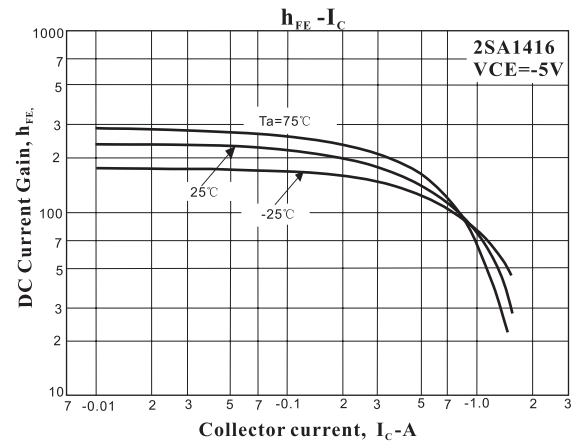
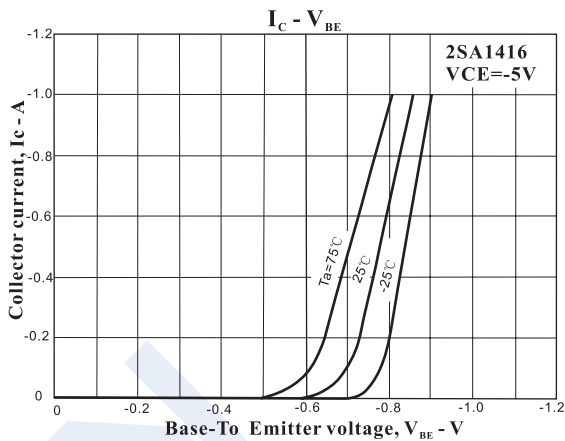
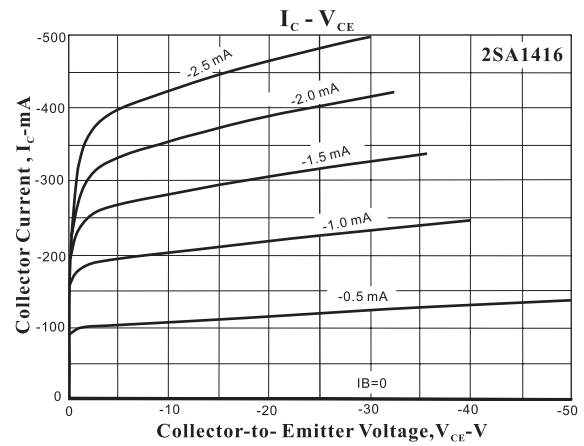
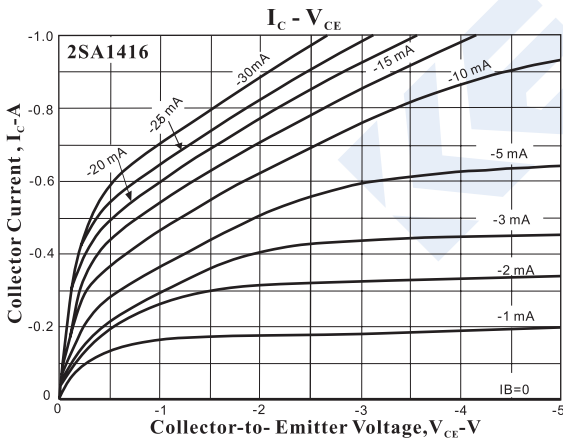

# 2SA1416

