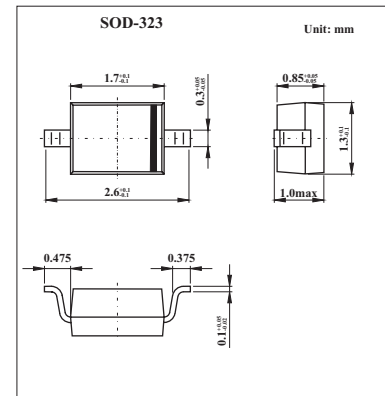

## Silicon Epitaxial Planar Diode

## 1SV328

## ■ Features

- High Capacitance Ratio:  $C_{1V}/C_{4V}=2.8$ (Typ.)
- Low Series Resistance:  $r_s=0.55 \Omega$  (Typ.)
- Useful for Small Size Tuner

■ Absolute Maximum Ratings  $T_a = 25^\circ\text{C}$ 

Parameter	Symbol	Value	Unit
Reverse Voltage	$V_R$	10	V
Junction Temperature	$T_j$	125	$^\circ\text{C}$
Storage Temperature Range	$T_{stg}$	-55 to +125	$^\circ\text{C}$

■ Electrical Characteristics  $T_a = 25^\circ\text{C}$ 

Parameter	Symbol	Conditions	Min	Typ	Max	Unit
Reverse Voltage	$V_R$	$I_R = 1 \mu\text{A}$	10			V
Reverse Current	$I_R$	$V_R = 10 \text{V}$			3	nA
Capacitance	$C_{1V}$	$f = 1 \text{MHz}; V_R = 1 \text{V}$	5.7		6.7	pF
	$C_{4V}$	$f = 1 \text{MHz}; V_R = 4 \text{V}$	1.85		2.45	
Capacitance Ratio	$C_{1V}/C_{4V}$		2.7	2.8		
Series Resistance	$r_s$	$V_R = 1 \text{V}, f = 470 \text{MHz}$		0.55	0.7	$\Omega$

## Note

1. Signal level when capacitance is measured:  $V_{sig} = 100 \text{mV}_{rms}$

## ■ Marking

Marking	V2