

## Schottky Rectifier Diodes

### KBR0520LW/0530W/0540W

(MBR0520LW/0530W/0540W)

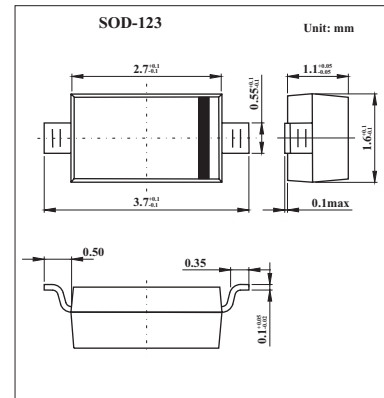

#### ■ Features

- Low forward voltage drop
- Guard ring construction for Transient protection.
- High conductance.
- Also available in lead free version.

#### ■ Absolute Maximum Ratings $T_a = 25^\circ\text{C}$

Parameter	Symbol	KBR0520LW	KBR0530W	KBR0540W	Unit
Peak repetitive peak reverse voltage	$V_{RRM}$				
Working peak	$V_{RWM}$	20	30	40	V
DC blocking voltage	$V_R$				
RMS reverse voltage	$V_{R(RMS)}$	14	21	28	V
Average rectified output current	$I_O$	500			mA
Peak forward surge current	$I_{FSM}$	5.5			A
Power dissipation	$P_d$	410			mW
Voltage rate of change	$dv/dt$	1000			V/ $\mu$ s
Thermal resistance junction to ambient	$R_{\theta JA}$	304			$^\circ\text{C}/\text{W}$
Storage temperature	$T_{stg}$	-65 to +125			$^\circ\text{C}$

#### ■ Electrical Characteristics $T_a = 25^\circ\text{C}$

Parameter	Symbol	Test conditions	Min	Typ	Max	Unit	
Minimum Reverse Breakdown Voltage	KBR0520LW	$V_{(BR)R}$	$I_R=250\ \mu\text{A}$			V	
	KBR0530W						$I_R=200\ \mu\text{A}$
	KBR0540W						$I_R=20\ \mu\text{A}$
Forward voltage	KBR0520LW	$V_{F1}$	$I_F=0.1\text{A}$			V	
	KBR0530W						0.3
Forward voltage	KBR0520LW	$V_{F2}$	$I_F=0.5\text{A}$			V	
	KBR0530W						0.375
	KBR0540W						0.430
Forward voltage	KBR0540W	$V_{F3}$	$I_F=1\text{A}$			V	
Reverse current	KBR0520LW	$I_{R1}$	$V_R=10\text{V}$	75		$\mu\text{A}$	
	KBR0530W	$I_{R2}$	$V_R=15\text{V}$	20		$\mu\text{A}$	
Reverse current	KBR0520LW	$I_{R3}$	$V_R=20\text{V}$	250		$\mu\text{A}$	
	KBR0540W			10		$\mu\text{A}$	
Reverse current	KBR0530W	$I_{R4}$	$V_R=30\text{V}$	130		$\mu\text{A}$	
	KBR0540W	$I_{R5}$	$V_R=40\text{V}$	20		$\mu\text{A}$	
Capacitance between terminals	$C_T$	$V_R=0\text{V}, f=1\text{MHz}$	170			pF	

#### ■ Marking

NO.	KBR0520LW	KBR0530W	KBR0540W
Marking	SD	SE	SF

**KBR0520LW/0530W/0540W**  
(MBR0520LW/0530W/0540W)

■ Typical Characteristics

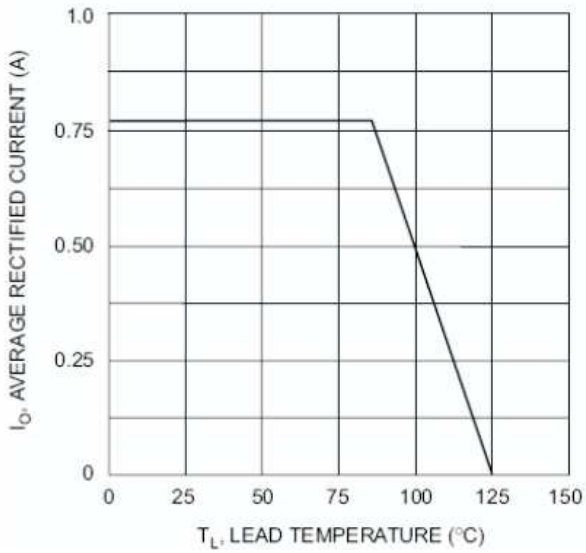

Fig.1 Forward Current Derating Curve

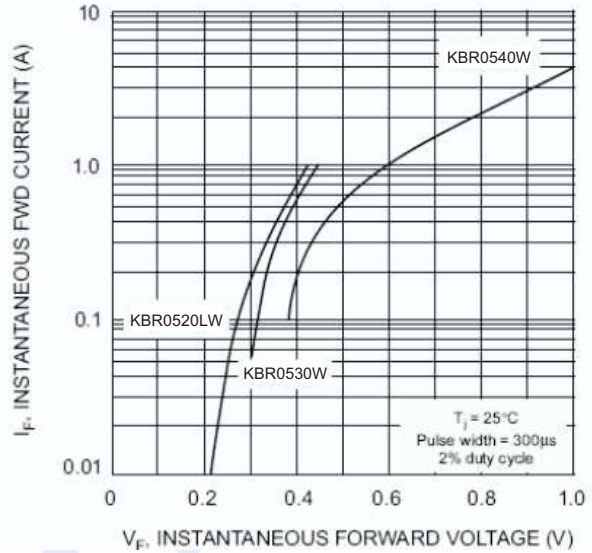

Fig.2 Typical Forward Characteristics

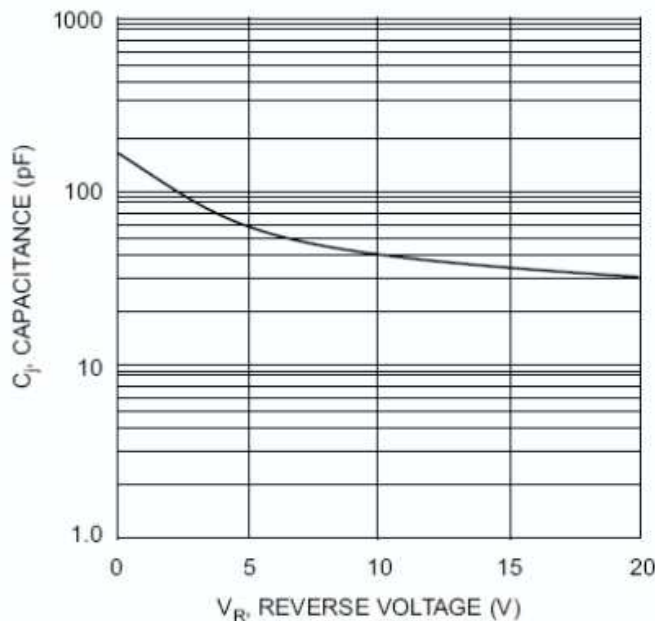

Fig.3 Typ. Junction Capacitance vs Reverse Voltage