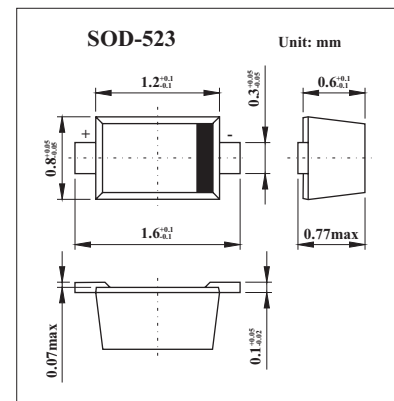

Silicon Schottky Barrier Diode

HSC226

■ Features

- Low reverse current, Low capacitance.
- Ultra small Flat Package (UFP) is suitable for surface mount design.

■ Absolute Maximum Ratings $T_a = 25^\circ\text{C}$

Parameter	Symbol	Value	Unit
Repetitive peak reverse voltage	V_{RRM}	25	V
Non-Repetitive peak forward surge current	I_{FSM}^*	200	mA
Forward current	I_F	50	mA
Junction temperature	T_j	125	$^\circ\text{C}$
Storage temperature	T_{stg}	-55 to +125	$^\circ\text{C}$

Note

10ms Sinewave 1pulse

■ Electrical Characteristics $T_a = 25^\circ\text{C}$

Parameter	Symbol	Conditions	Min	Typ	Max	Unit
Forward voltage	V_F	$I_F = 1\text{ mA}$			0.33	V
		$I_F = 5\text{ mA}$			0.38	
Reverse current	I_R	$V_R = 20\text{ V}$			0.45	$\mu\text{ A}$
Capacitance	C	$V_R = 1\text{ V}, f = 1\text{ MHz}$			2.80	pF

■ Marking

Marking	S4
---------	----