

Ultra-Low Noise, Low Sensitivity Tolerance, PDM Digital Microphone

GENERAL DESCRIPTION

The ADMP522* is an omnidirectional, bottom-ported, digital output MEMS microphone with high performance, ultralow noise, and low power. The ADMP522 has a sensitivity tolerance of ± 1 dB from part to part, making it ideal for microphone array and beamforming applications.

The ADMP522 consists of a MEMS microphone element and an impedance converter amplifier followed by a fourth-order Σ - Δ modulator. The digital interface enables the pulse density modulated (PDM) output of two microphones to be time-multiplexed on a single data line using a single clock. The ADMP522 is function- and pin-compatible with the ADMP521 and ADMP421 microphones, providing an easy upgrade path.

The ADMP522 has a very high signal-to-noise ratio (SNR) of 65 dBA and sensitivity of -26 dBFS, making it an excellent choice for near- and far-field applications. The ADMP522 has an extended wideband frequency response, resulting in natural sound with high intelligibility. Low current consumption and a sleep mode with less than $2 \mu\text{A}$ current consumption enables long battery life for portable applications.

The ADMP522 is available in a thin $4 \times 3 \times 1$ mm surface-mount package. It is reflow solder compatible with no sensitivity degradation.

*Protected by U.S. Patents 7,449,356; 7,825,484; 7,885,423; and 7,961,897. Other patents are pending.

FUNCTIONAL BLOCK DIAGRAM

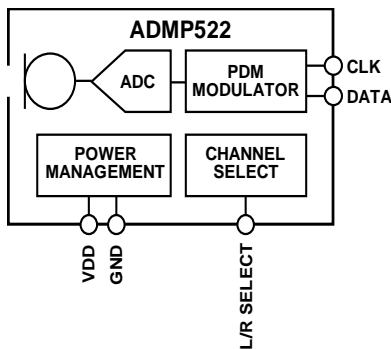

APPLICATIONS

- Smartphones and Feature Phones
- Microphone Arrays
- Tablet Computers
- Teleconferencing Systems
- Digital Still and Video Cameras
- Bluetooth Headsets
- Notebook PCs
- Security and Surveillance

FEATURES

- Sensitivity Tolerance of ± 1 dB
- Small, Thin $4 \times 3 \times 1$ mm Surface-Mount Package
- Omnidirectional Response
- Very High SNR of 65 dBA
- Sensitivity of -26 dBFS
- Wide Frequency Response from 75 Hz to >20 kHz
- Low Current Consumption of $800 \mu\text{A}$
- Sleep Mode for Extended Battery Life, $<2 \mu\text{A}$
- Acoustic Overload Point of 116 dB SPL
- High PSR of -83 dBFS
- Fourth-Order Σ - Δ Modulator
- Digital PDM Output
- Sn/Pb and Pb-Free Solder Processes
- RoHS/WEEE Compliant

ORDERING INFORMATION

PART	TEMP RANGE	PACKAGE
ADMP522ACEZ-RL	-40°C to $+85^{\circ}\text{C}^*$	CE-5-1
ADMP522ACEZ-RL7	-40°C to $+85^{\circ}\text{C}^{\dagger}$	CE-5-1
EVAL-ADMP522Z-FLEX	—	—

* – 13" Tape and Reel † – 7" Tape and Reel

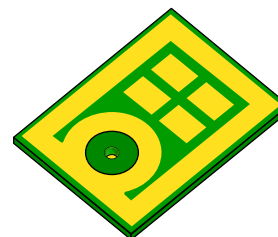

BOTTOM

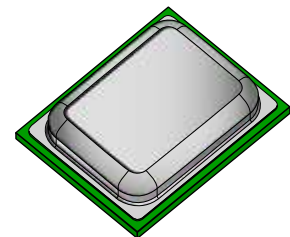

TOP

TABLE OF CONTENTS

General Description 1

Applications 1

Features 1

Functional Block Diagram 1

Ordering Information 1

Table of Contents 2

Specifications 4

 Table 1. Electrical Characteristics 4

 Table 2. Timing Characteristics 5

 Timing Diagram 5

Absolute Maximum Ratings 6

 Table 3. Absolute Maximum Ratings 6

 ESD Caution 6

 Soldering Profile 7

 Table 4. Recommended Soldering Profile 7

Pin Configurations And Function Descriptions 8

 Table 5. Pin Function Descriptions 8

Typical Performance Characteristics 9

Theory Of Operation 10

 PDM Data Format 10

 Table 6. ADMP522 Channel Setting 10

 PDM Microphone Sensitivity 11

 Connecting PDM Microphones 12

 Sleep Mode 14

 Start-Up Time 14

Supporting Documents 15

 Evaluation Board User Guide 15

 Circuit Note 15

 Application Notes 15

PCB Design And Land Pattern Layout 16

 Alternative PCB Land Patterns 17

 PCB Material And Thickness 17

Handling Instructions 18

 Pick And Place Equipment 18

 Reflow Solder 18

 Board Wash 18

Outline Dimensions.....	19
Ordering Guide	19
Revision History	19
Compliance Declaration Disclaimer:	20
Environmental Declaration Disclaimer:	20

SPECIFICATIONS

TABLE 1. ELECTRICAL CHARACTERISTICS

($T_A = -40$ to 85°C , $V_{DD} = 1.8$ to 3.3 V, $\text{CLK} = 2.4$ MHz, $C_{LOAD} = 30$ pF, unless otherwise noted. All minimum and maximum specifications are guaranteed across temperature, voltage, and clock frequency specified in Table 1, unless otherwise noted. Typical specifications are not guaranteed.)

PARAMETER		CONDITIONS	MIN	TYP	MAX	UNITS	NOTES
PERFORMANCE							
Directionality				Omni			
Sensitivity		1 kHz, 94 dB SPL	-27	-26	-25	dBFS	1
Signal-to-Noise Ratio (SNR)		20 Hz to 20 kHz, A-weighted		65		dB	
Equivalent Input Noise (EIN)		20 Hz to 20 kHz, A-weighted		29		dB SPL	
Dynamic Range		Derived from EIN and maximum acoustic input		91		dB	
Frequency Response		Low frequency -3 dB point		75		Hz	2
		High frequency -3 dB point		>20		kHz	
Total Harmonic Distortion (THD)		105 dB SPL		0.5	1.5	%	
Power-Supply Rejection (PSR)		217 Hz, 100 mVp-p square wave superimposed on $V_{DD} = 1.8$ V		-83		dBFS	
Acoustic Overload Print		10% THD		116		dB SPL	
Full-Scale Acoustic Level		0 dBFS, derived from sensitivity		120		dBFS	
POWER SUPPLY							
Supply Voltage (V_{DD})			1.62		3.63	V	
Supply Current (I_S)							
$V_{DD} = 1.8$ V	Normal Mode			0.8	1.2	mA	
	Sleep Mode				2	μA	3
$V_{DD} = 3.3$ V	Normal Mode			1.0	1.4	mA	
	Sleep Mode				3	μA	3
DIGITAL FILTER							
Input Voltage High (V_{IH})			$0.65 \times V_{DD}$			V	
Input Voltage Low (V_{IL})					$0.35 \times V_{DD}$	V	
Output Voltage High (V_{OH})		$I_{LOAD} = 0.5$ mA	$0.7 \times V_{DD}$	V_{DD}		V	
Output Voltage Low (V_{OL})		$I_{LOAD} = 0.5$ mA		0	$0.3 \times V_{DD}$	V	
Output DC Offset		Percent of full scale		5		%	
Latency				<30		μs	
Noise Floor		20 Hz to 20 kHz, A-weighted		-91		dBFS	

Note 1: Relative to the RMS level of sine wave with positive amplitude equal to 100% logical 1s density and negative amplitude equal to 0% logical 1s density.

Note 2: See Figure 4 and Figure 5.

Note 3: The microphone enters sleep mode when the clock frequency is less than 1kHz.

TABLE 2. TIMING CHARACTERISTICS

$T_A = -40$ to 85°C , $V_{DD} = 1.8$ to 3.3 V, $\text{CLK} = 2.4$ MHz, $C_{LOAD} = 30$ pF, unless otherwise noted. All minimum and maximum specifications are guaranteed. Typical specifications are not guaranteed.

PARAMETER	CONDITIONS	MIN	TYP	MAX	UNITS	NOTES
SLEEP MODE						
Sleep Time	Time from CLK falling ($f_{CLK} < 1$ kHz)		30		μs	1
Wake-Up Time	Time from CLK rising ($f_{CLK} > 1$ kHz), power on		10		ms	1
INPUT						
t_{CLKIN}	Input clock period	270		1111	ns	1
Clock Frequency (CLK)		0.9	2.4	3.6	MHz	
Clock Duty Cycle		40		60	%	
OUTPUT						
T_{1OUTEN}	DATA1 (right) driven after falling clock edge	54			ns	
$T_{1OUTDIS}$	DATA1 (right) disabled after rising clock edge	15		54	ns	
T_{2OUTEN}	DATA2 (left) driven after rising clock edge	54			ns	
$T_{2OUTDIS}$	DATA2 (left) disabled after falling clock edge	15		54	ns	

Note 1: The microphone operates at any clock frequency between 0.9 MHz and 3.6 MHz. Some specifications may not be guaranteed at frequencies other than 2.4 MHz.

TIMING DIAGRAM

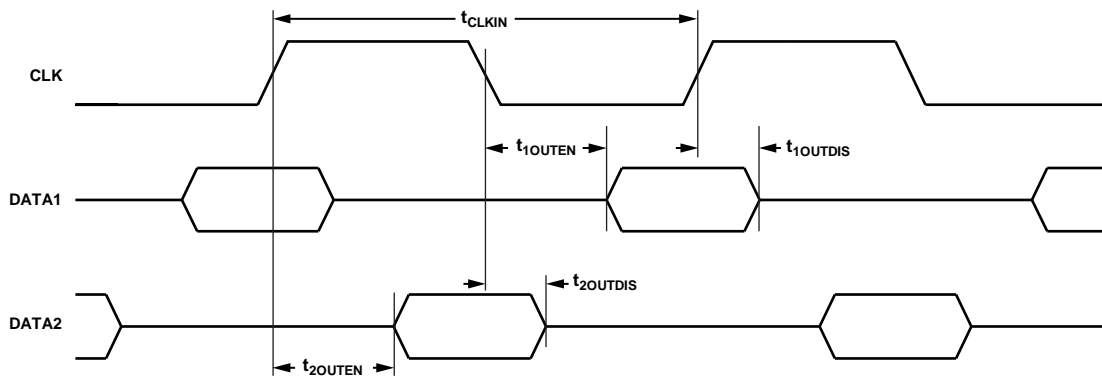

Figure 1. Pulse Density Modulated Output Timing

ABSOLUTE MAXIMUM RATINGS

Stress above those listed as Absolute Maximum Ratings may cause permanent damage to the device. These are stress ratings only and functional operation of the device at these conditions is not implied. Exposure to the absolute maximum ratings conditions for extended periods may affect device reliability.

TABLE 3. ABSOLUTE MAXIMUM RATINGS

PARAMETER	RATING
Supply Voltage (V_{DD})	-0.3 V to +3.63 V
Digital Pin Input Voltage	-0.3 V to $V_{DD} + 0.3$ V or 3.63 V, whichever is less
Sound Pressure Level	160 dB
Mechanical Shock	10,000 <i>g</i>
Vibration	Per MIL-STD-883 Method 2007, Test Condition B
Temperature Range	
Biased	-40°C to +85°C
Storage	-55°C to +150°C

ESD CAUTION



ESD (electrostatic discharge) sensitive device. Charged devices and circuit boards can discharge without detection. Although this product features patented or proprietary protection circuitry, damage may occur on devices subjected to high energy ESD. Therefore proper ESD precautions should be taken to avoid performance degradation or loss of functionality.

SOLDERING PROFILE

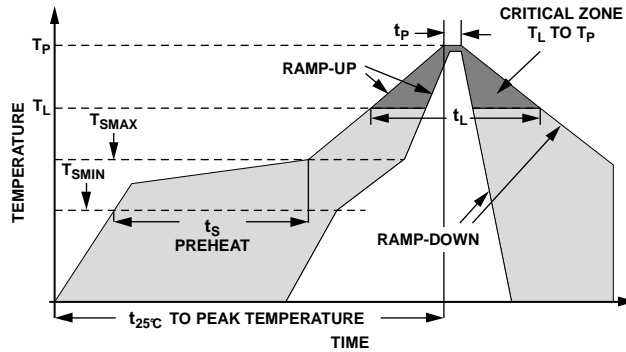

Figure 2. Recommended Soldering Profile Limits

TABLE 4. RECOMMENDED SOLDERING PROFILE

PROFILE FEATURE		Sn63/Pb37	Pb-Free
Average Ramp Rate (T_L to T_P)		1.25°C/sec max	1.25°C/sec max
Preheat	Minimum Temperature (T_{SMIN})	100°C	100°C
	Minimum Temperature (T_{SMIN})	150°C	200°C
	Time (T_{SMIN} to T_{SMAX}), t_s	60 sec to 75 sec	60 sec to 75 sec
Ramp-Up Rate (T_{SMAX} to T_L)		1.25°C/sec	1.25°C/sec
Time Maintained Above Liquidous (t_L)		45 sec to 75 sec	~50 sec
Liquidous Temperature (T_L)		183°C	217°C
Peak Temperature (T_P)		215°C +3°C/-3°C	260°C +0°C/-5°C
Time Within +5°C of Actual Peak Temperature (t_p)		20 sec to 30 sec	20 sec to 30 sec
Ramp-Down Rate		3°C/sec max	3°C/sec max
Time +25°C ($t_{25^\circ\text{C}}$) to Peak Temperature		5 min max	5 min max

PIN CONFIGURATIONS AND FUNCTION DESCRIPTIONS

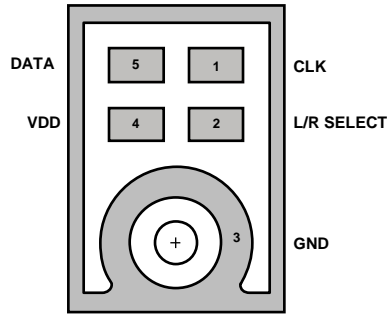

Figure 3. Pin Configuration

TABLE 5. PIN FUNCTION DESCRIPTIONS

PIN	NAME	FUNCTION
1	CLK	Clock Input to Microphone
2	L/R SELECT	Left Channel or Right Channel Select: DATA 1 (right): L/R SELECT tied to GND DATA 2 (left): L/R SELECT tied to VDD
3	GND	Ground
4	VDD	Power Supply. For best performance and to avoid potential parasitic artifacts, place a 0.1 μ F (100 nF) ceramic type X7R capacitor between Pin 4 (VDD) and ground. Place the capacitor as close to Pin 4 as possible.
5	DATA	Digital Output Signal (DATA1 or DATA2)

TYPICAL PERFORMANCE CHARACTERISTICS

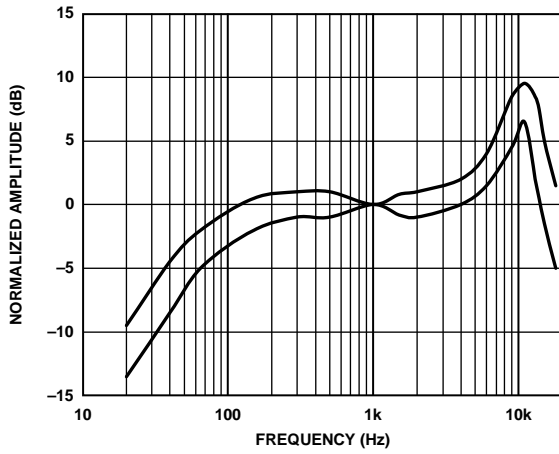

Figure 4. Frequency Response Mask

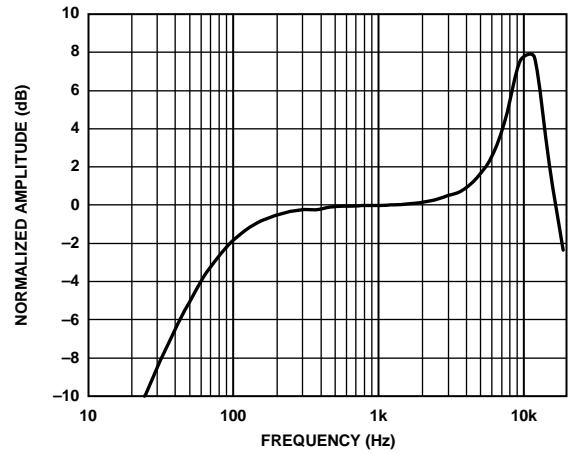

Figure 5. Typical Frequency Response (Measured)

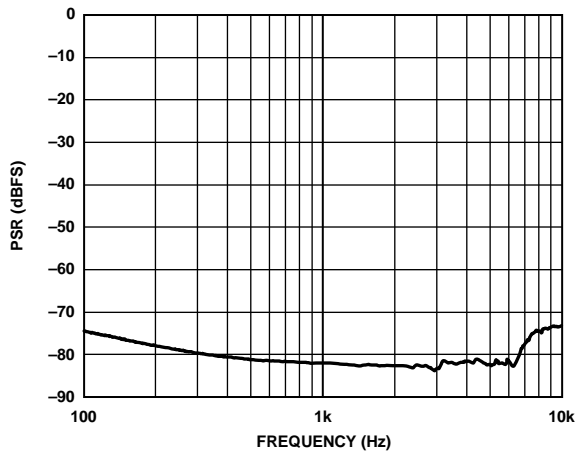

Figure 6. Power Supply Rejection (PSR) vs. Frequency

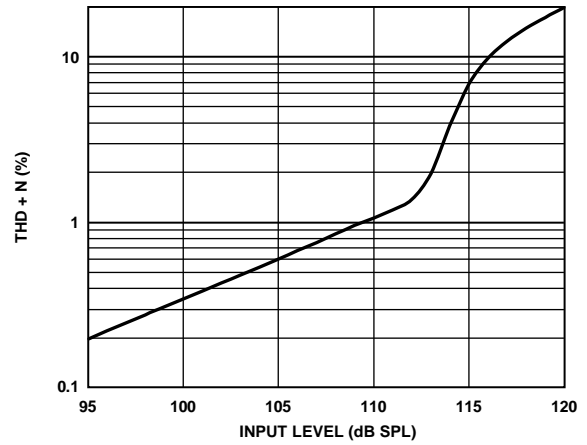

Figure 7. THD+N vs. Input SPL

THEORY OF OPERATION

PDM DATA FORMAT

The output from the DATA pin of the ADMP522 is in PDM format. This data is the 1-bit output of a fourth-order Σ - Δ modulator. The data is encoded so that the left channel is clocked on the falling edge of CLK and the right channel is clocked on the rising edge of CLK.

After driving the DATA signal high or low in the appropriate half frame of the CLK signal, the DATA driver of the microphone is tristated. In this way, two microphones—one set to the left channel and the other to the right channel—can drive a single DATA line.

Figure 1 shows a timing diagram of the PDM data format; the DATA1 and DATA2 lines shown in Figure 1 are two halves of the single physical DATA signal. Figure 8 shows a diagram of the two stereo channels sharing a common DATA line.

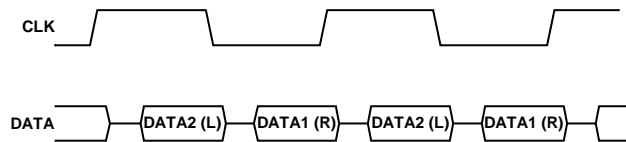

Figure 8. Stereo PDM Format

If only one microphone is connected to the DATA signal, the output is clocked on a single edge only (See Figure 9.)

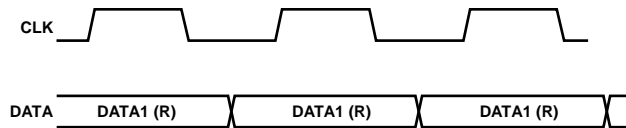

Figure 9. Mono PDM Format

For example, a left channel microphone is never clocked on the rising edge of CLK. In a single microphone application, each bit of the DATA signal is typically held for the full CLK period until the next transition of the CLK signal because the leakage of the DATA line is not sufficient to discharge the line while the driver is tristated.

The channel assignments are determined by the logic level on the L/R SELECT pin (see Table 6.)

TABLE 6. ADMP522 CHANNEL SETTING

L/R SELECT Pin Setting	Channel
Low (tie to GND)	Right (DATA1)
High (tie to VDD)	Left (DATA2)

For PDM data, the density of the pulses indicates the signal amplitude. A high density of high pulses indicates a signal near positive full scale, and a high density of low pulses indicates a signal near negative full scale. A perfect zero (dc) audio signal is indicated by an alternating pattern of high and low pulses.

The output PDM data signal has a small dc offset of approximately 5% of full scale. A high-pass filter in the codec that is connected to the digital microphone typically removes this dc signal and does not affect the performance of the microphone.

PDM MICROPHONE SENSITIVITY

The sensitivity of a PDM output microphone is specified in units of dBFS (decibels relative to a full-scale digital output). A 0 dBFS sine wave is defined as a signal whose peak just touches the full-scale code of the digital word (see Figure 10). This measurement convention means that signals with a different crest factor may have an RMS level higher than 0 dBFS. For example, a full-scale square wave has an RMS level of 3 dBFS.

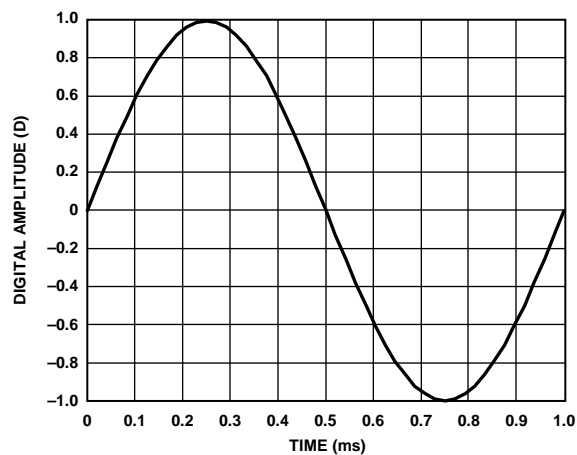

Figure 10. 1 kHz, 0 dBFS Sine Wave

The definition of a 0 dBFS signal must be understood when measuring the sensitivity of the ADMP522. An acoustic input signal of a 1 kHz sine wave at 94 dB SPL applied to the ADMP522 results in an output signal with a -26 dBFS level. This means that the output digital word peaks at -26 dB below the digital full-scale level. A common misunderstanding is that the output has an RMS level of -29 dBFS; however, this is not the case because of the definition of a 0 dBFS sine wave.

There is no commonly accepted unit of measurement to express the instantaneous level of a digital signal output from the microphone, as opposed to the RMS level of the signal. Some measurement systems express the instantaneous level of an individual sample in units of D, where 1.0 D is digital full scale (see Figure 10). In this case, a -26 dBFS sine wave has peaks at 0.05 D.

For more information about digital microphone sensitivity, see the AN-1112 Application Note, *Microphone Specifications Explained*.

CONNECTING PDM MICROPHONES

A PDM output microphone is typically connected to a codec with a dedicated PDM input. This codec separately decodes the left and right channels and filters the high sample rate modulated data back to the audio frequency band. The codec also generates the clock for the PDM microphones or is synchronous with the source that generates the clock.

Figure 11 and Figure 12 show mono and stereo connections between the ADMP522 and a codec. The mono connection shows an ADMP522 set to output data on the right channel. To output data on the left channel, tie the L/R SELECT pin to VDD instead of GND.

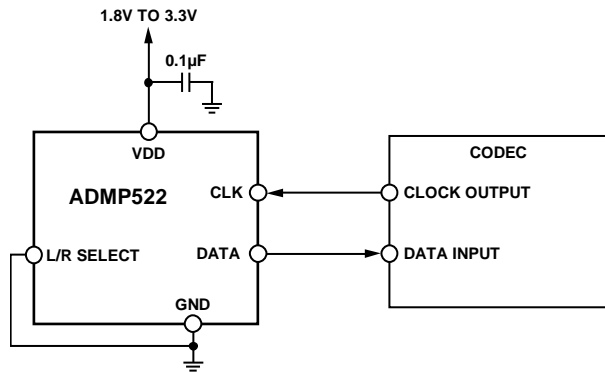

Figure 11. Mono PDM Microphone (Right Channel) Connection to Codec

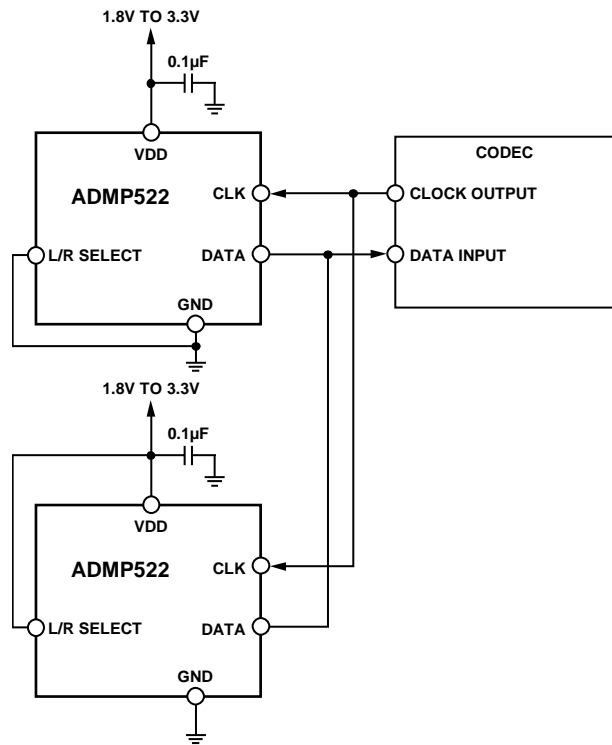

Figure 12. Stereo PDM Microphone Connection to Codec

Decouple the VDD pin of the ADMP522 to GND with a 0.1 μF capacitor. Place this capacitor as close to V_{DD} as the printed circuit board (PCB) layout allows.

Do not use a pull-up or pull-down resistor on the PDM data signal line because the resistor can pull the signal to an incorrect state during the period that the signal line is tristated.

The DATA signal does not need to be buffered in normal use when the ADMP522 microphones are placed close to the codec on the PCB. If the ADMP522 must drive the DATA signal over a long cable (>15 cm) or other large capacitive load, a digital buffer may be needed. Use a signal buffer on the DATA line only when one microphone is in use or after the point where two microphones are connected (see Figure 13.)

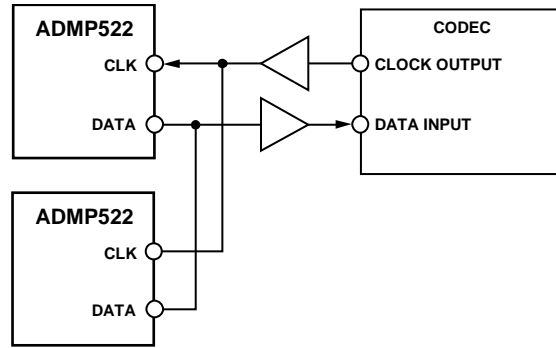

Figure 13. Buffered Connection Between stereo ADMP522 Devices and a Codec

The DATA output of each microphone in a stereo configuration cannot be individually buffered because the two buffer outputs cannot drive a single signal line. If a buffer is used, take care to select a buffer with low propagation delay so that the timing of the data connected to the codec is not corrupted.

When long wires are used to connect the codec to the ADMP522, a 100 Ω source termination resistor can be used on the clock output of the codec instead of a buffer to minimize signal over-shoot or ringing. Depending on the drive capability of the codec clock output, a buffer may still be needed, as shown in Figure 13.

SLEEP MODE

The microphone enters sleep mode when the clock frequency falls below 1 kHz. In sleep mode, the microphone data output is in a high impedance state. The current consumption of the ADMP522 in sleep mode is less than 2 μA at V_{DD} = 1.8 V.

The ADMP522 enters sleep mode within 1ms of the clock frequency falling below 1 kHz. The microphone wakes up from sleep mode 32,768 cycles after the clock becomes active. For a 2.4 MHz clock, the microphone begins to output data in 13.7 ms. The wake-up time, as specified in Table 2, indicates the time from when the clock is enabled to when the ADMP522 is consuming its specified current.

START-UP TIME

The start-up time of the ADMP522 from when the clock is active is the same as the wake-up time from sleep mode. The microphone starts up 32,768 cycles after the clock is active.

SUPPORTING DOCUMENTS

For additional information, see the following documents.

EVALUATION BOARD USER GUIDE

[UG-326](#), PDM Digital Output MEMS Microphone Evaluation Board

CIRCUIT NOTE

[CN-0078](#), High Performance Digital MEMS Microphone Simple Interface to a SigmaDSP Audio Codec

APPLICATION NOTES

[AN-1003](#), Recommendations for Mounting and Connecting the InvenSense, Bottom-Ported MEMS Microphones

[AN-1068](#), Reflow Soldering of the MEMS Microphone

[AN-1112](#), Microphone Specifications Explained

[AN-1124](#), Recommendations for Sealing InvenSense, Bottom-Port MEMS Microphones from Dust and Liquid Ingress

[AN-1140](#), Microphone Array Beamforming

PCB DESIGN AND LAND PATTERN LAYOUT

Lay out the PCB land pattern for the ADMP522 at a 1:1 ratio to the solder pads on the microphone package (see Figure 14.) Take care to avoid applying solder paste to the sound hole in the PCB. Figure 15 shows a suggested solder paste stencil pattern layout. The response of the ADMP522 is not affected by the PCB hole size, as long as the hole is not smaller than the sound port of the microphone (0.25 mm, or 0.010 inch, in diameter). A 0.5 mm to 1 mm (0.020 inch to 0.040 inch) diameter for the hole is recommended.

Align the hole in the microphone package with the hole in the PCB. The exact degree of the alignment does not affect the performance of the microphone as long as the holes are not partially or completely blocked.

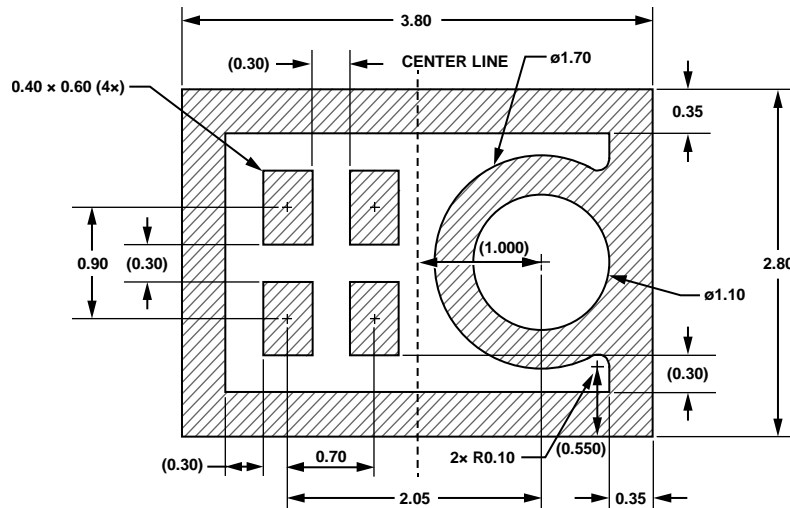

Figure 14. Suggested PCB Land Pattern Layout
Dimensions shown in millimeters

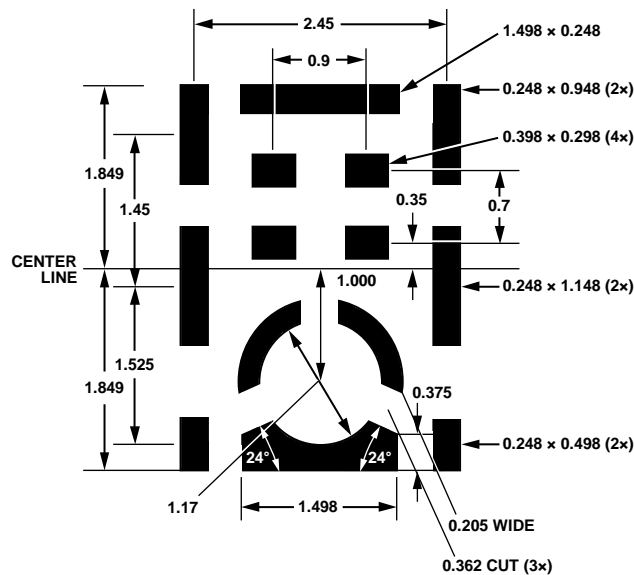

Figure 15. Suggested Solder Paste Stencil Pattern Layout
Dimensions shown in millimeters

ALTERNATIVE PCB LAND PATTERNS

The standard PCB land pattern of the ADMP522 has a solid rectangle around the edge of the footprint (see Figure 14). In some board designs, this rectangle can make routing the microphone signals more difficult. The rectangle is used to improve the RF immunity performance of the ADMP522; however, it is not necessary to have the full rectangle connected for electrical functionality. If a design can tolerate reduced RF immunity, this rectangle can either be broken or removed completely from the PCB footprint.

Figure 16 shows an example PCB land pattern with no enclosing rectangle around the edge of the part.

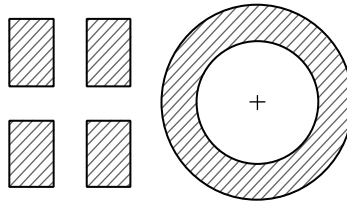

Figure 16. Example PCB Land Pattern with No Enclosing Rectangle

Figure 17 shows an example PCB land pattern with the rectangle broken on two sides so that the inner pads can be more easily routed on the PCB.

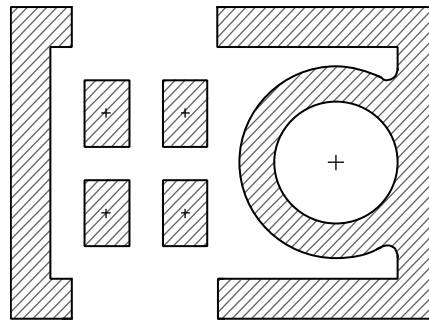

Figure 17. Example PCB Land Pattern with Broken Enclosing Rectangle

Note that in both of these patterns, the solid ring around the sound port is still present; this ring is needed to ground the microphone and for acoustic performance. The pad on the package connected to this ring is ground and still needs a solid electrical connection to the PCB ground.

If a land pattern similar to Figure 16 or Figure 17 is used on a PCB, make sure that the unconnected rectangle on the bottom of the ADMP522 is not placed directly over any exposed copper. The rectangle on the microphone is still at ground, and any PCB traces routed beneath it must be properly masked to avoid short circuits.

PCB MATERIAL AND THICKNESS

The performance of the ADMP522 is not affected by PCB thickness. The ADMP522 can be mounted on either a rigid or flexible PCB. A flexible PCB with the microphone can be attached directly to the device housing with an adhesive layer. This mounting method offers a reliable seal around the sound port, while providing the shortest acoustic path for good sound quality.

HANDLING INSTRUCTIONS

PICK AND PLACE EQUIPMENT

The MEMS microphone can be handled using standard pick-and-place and chip shooting equipment. Take care to avoid damage to the MEMS microphone structure as follows:

- Use a standard pickup tool to handle the microphone. Because the microphone hole is on the bottom of the package, the pickup tool can make contact with any part of the lid surface.
- Do not pick up the microphone with a vacuum tool that makes contact with the bottom side of the microphone. Do not pull air out of or blow air into the microphone port.
- Do not use excessive force to place the microphone on the PCB.

REFLOW SOLDER

For best results, the soldering profile must be in accordance with the recommendations of the manufacturer of the solder paste used to attach the MEMS microphone to the PCB. It is recommended that the solder reflow profile not exceed the limit conditions specified in Figure 2 and Table 4.

BOARD WASH

When washing the PCB, ensure that water does not make contact with the microphone port. Do not use blow-off procedures or ultrasonic cleaning.

OUTLINE DIMENSIONS

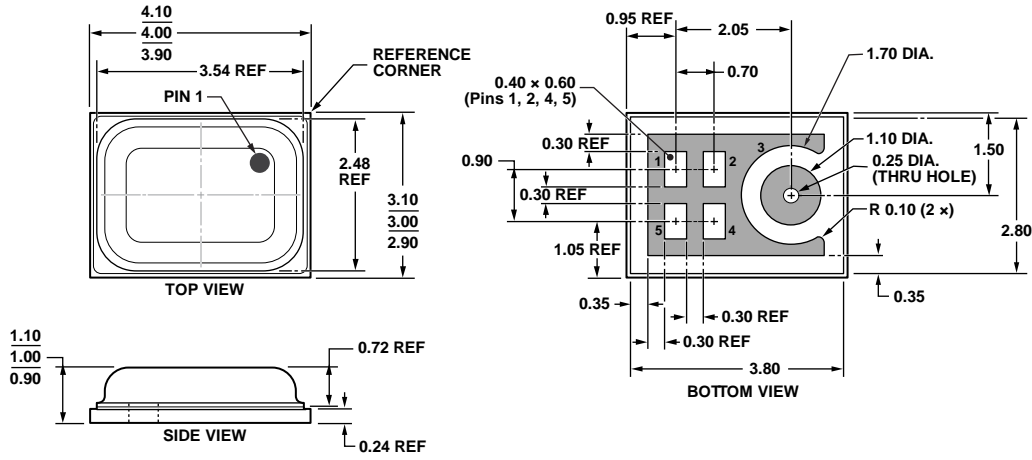

Figure 18. 5-Terminal Chip Array Small Outline No Lead Cavity [LGA_CAV]
 4 mm x 3 mm Body
 (CE-5-1)
 Dimensions shown in millimeters

04-19-2012-G

ORDERING GUIDE

PART	TEMP RANGE	PACKAGE	PACKAGE OPTION	QUANTITY
ADMP522ACEZ-RL	-40°C to +85°C	5-Terminal LGA_CAV*	CE-5-1	5,000
ADMP522ACEZ-RL7	-40°C to +85°C	5-Terminal LGA_CAV†	CE-5-1	1,000
EVAL-ADMP522Z-FLEX	—	Flexible Evaluation Board	—	—

* – 13" Tape and Reel † – 7" Tape and

REVISION HISTORY

REVISION DATE	REVISION	DESCRIPTION
11/11/2013	1.0	Initial Release

Compliance Declaration Disclaimer:

InvenSense believes this compliance information to be correct but cannot guarantee accuracy or completeness. Conformity documents for the above component constitutes are on file. InvenSense subcontracts manufacturing and the information contained herein is based on data received from vendors and suppliers, which has not been validated by InvenSense

Environmental Declaration Disclaimer:

InvenSense believes this environmental information to be correct but cannot guarantee accuracy or completeness. Conformity documents for the above component constitutes are on file. InvenSense subcontracts manufacturing and the information contained herein is based on data received from vendors and suppliers, which has not been validated by InvenSense

This information furnished by InvenSense is believed to be accurate and reliable. However, no responsibility is assumed by InvenSense for its use, or for any infringements of patents or other rights of third parties that may result from its use. Specifications are subject to change without notice. InvenSense reserves the right to make changes to this product, including its circuits and software, in order to improve its design and/or performance, without prior notice. InvenSense makes no warranties, neither expressed nor implied, regarding the information and specifications contained in this document. InvenSense assumes no responsibility for any claims or damages arising from information contained in this document, or from the use of products and services detailed therein. This includes, but is not limited to, claims or damages based on the infringement of patents, copyrights, mask work and/or other intellectual property rights.

Certain intellectual property owned by InvenSense and described in this document is patent protected. No license is granted by implication or otherwise under any patent or patent rights of InvenSense. This publication supersedes and replaces all information previously supplied. Trademarks that are registered trademarks are the property of their respective companies. InvenSense sensors should not be used or sold in the development, storage, production or utilization of any conventional or mass-destructive weapons or for any other weapons or life threatening applications, as well as in any other life critical applications such as medical equipment, transportation, aerospace and nuclear instruments, undersea equipment, power plant equipment, disaster prevention and crime prevention equipment.

©2013 InvenSense, Inc. All rights reserved. InvenSense, MotionTracking, MotionProcessing, MotionProcessor, MotionFusion, MotionApps, DMP, and the InvenSense logo are trademarks of InvenSense, Inc. Other company and product names may be trademarks of the respective companies with which they are associated.



©2013 InvenSense, Inc. All rights reserved.