



InvenSense Inc.
1197 Borregas Ave, Sunnyvale, CA 94089 U.S.A.
Tel: +1 (408) 988-7339 Fax: +1 (408) 988-8104
Website: www.invensense.com

PS-ISZ-1315B-00-01
Release Date: 09/22/11

ISZ-1315 Single-Axis Z-Gyro Product Specification

A printed copy of this document is
NOT UNDER REVISION CONTROL
unless it is dated and stamped in red ink as,
"REVISION CONTROLLED COPY."



TABLE OF CONTENTS

1. REVISION HISTORY	4
2. PURPOSE AND SCOPE	5
3. PRODUCT OVERVIEW	5
4. FEATURES	5
5. FUNCTIONAL BLOCK DIAGRAM	6
6. FUNCTIONAL DESCRIPTION	6
6.1 OVERVIEW	6
6.2 RATE SENSOR	6
6.3 OSCILLATOR CIRCUIT	6
6.4 AMPLITUDE CONTROL	6
6.5 CORIOLIS SENSE	7
6.6 DEMODULATOR	7
6.7 LOW-PASS FILTER	7
6.8 HIGH-PASS FILTER	7
6.9 HIGH-PASS FILTER RESET SWITCH	7
6.10 AUTO ZERO	7
6.11 TEMPERATURE SENSOR	7
6.12 CHARGE PUMP	7
6.13 MEMORY TRIM	7
6.14 SCALE FACTOR	7
6.15 REFERENCE VOLTAGE	7
7. SPECIFICATION	8
7.1 SPECIFIED PARAMETERS	8
7.2 SPECIFIED PARAMETERS, CONTINUED	9
7.3 RECOMMENDED OPERATING CONDITIONS	9
7.4 ABSOLUTE MAXIMUM RATINGS	9
7.5 REFERENCE CIRCUIT	10
8. APPLICATION INFORMATION	11
8.1 PIN OUT AND SIGNAL DESCRIPTION	11
8.2 DESIGN CONSIDERATIONS	12
8.2.1 POWER SUPPLY REJECTION RATIO	12
8.2.2 POWER SUPPLY FILTERING	12
8.2.3 AMPLITUDE CONTROL	12
8.2.4 TEMPERATURE SENSOR	12



8.2.5	INTERNAL LOW-PASS FILTER.....	12
8.2.6	EXTERNAL LOW-PASS CIRCUITRY.....	13
8.2.7	HIGH-PASS FILTER	13
8.2.8	HIGH-PASS FILTER RESET	13
8.2.9	AUTO ZERO.....	14
8.2.10	HIGH IMPEDANCE NODES.....	14
8.2.11	CHARGE PUMP	14
8.2.12	PROPER INTERFACE CLEANING	14
8.2.13	ACOUSTIC NOISE SENSITIVITY.....	14
8.2.14	ELECTROSTATIC DISCHARGE SENSITIVITY	14
9.	ASSEMBLY	15
9.1	ORIENTATION OF AXES	15
9.2	PACKAGE DIMENSIONS:	16
9.3	PCB DESIGN GUIDELINES:.....	17
9.4	ASSEMBLY PRECAUTIONS	18
9.5	STORAGE SPECIFICATIONS.....	21
9.6	PACKAGE MARKING SPECIFICATION.....	21
9.7	TAPE & REEL SPECIFICATION	22
9.8	LABEL	23
9.9	PACKAGING.....	24
10.	RELIABILITY	25
10.1	QUALIFICATION TEST POLICY	25
10.2	QUALIFICATION TEST PLAN	25
11.	ENVIRONMENTAL COMPLIANCE.....	26

	ISZ-1315 Single-Axis Z-Gyroscope Product Specification	PS-ISZ-1315B-00-01 Release Date: 09/22/11
---	---	--

1. Revision History

Revision Date	Revision	Description
09/22/11	01	Initial Release

PRELIMINARY



2. Purpose and Scope

This document is a preliminary product specification, providing a description, specifications, and hardware design related information relating to the ISZ-1315 gyroscope.

Electrical characteristics in this preliminary document are based upon simulation results and limited characterization data of advanced samples only. Specifications are subject to change without notice. Final specifications will be updated based upon characterization of final silicon.

3. Product Overview

The ISZ-1315 is a state-of-the-art single-axis Z-gyroscope designed specifically for complex motion sensing in navigation and general-purpose motion-sensing applications. The ISZ-1315 gyroscope utilizes state-of-the-art MEMS fabrication with wafer-scale integration technology. This technology combines completed MEMS wafers and completed CMOS electronic wafers together using a patented and proprietary wafer-scale bonding process that simultaneously provides electrical connections and hermetically sealed enclosures. This unique and novel fabrication technique is the key enabling technology that allows for the design and manufacture of high performance, integrated MEMS gyroscopes in a very small and economical package. Integration at the wafer-level minimizes parasitic capacitances, allowing for improved signal-to-noise over a discrete solution. With the addition of the new patent-pending Auto Zero feature for minimizing bias drift over temperature, the ISZ-1315 offers unparalleled gyroscope performance in 3D-input and gaming applications.

4. Features

By integrating the control electronics with the sensor elements at the wafer level, the ISZ-1315 gyroscope supports a rich feature set including:

- Z-axis (yaw rate) gyro on a single chip
- Full-scale range of $\pm 67^\circ/\text{sec}$
- Factory calibrated scale factor of $15\text{mV}/\%/\text{sec}$
- Integrated amplifiers and low-pass filter
- Auto Zero function
- High-pass filter reset function
- On-chip temperature sensor
- High vibration rejection over wide frequency range
- High cross-axis isolation by proprietary MEMS design
- 3V single-supply operation
- Hermetically sealed for temperature and humidity resistance
- 10,000 *g* shock tolerant
- Small single axis gyro package at 4 x 4 x 0.9mm
- RoHS and Green Compliant

5. Functional Block Diagram

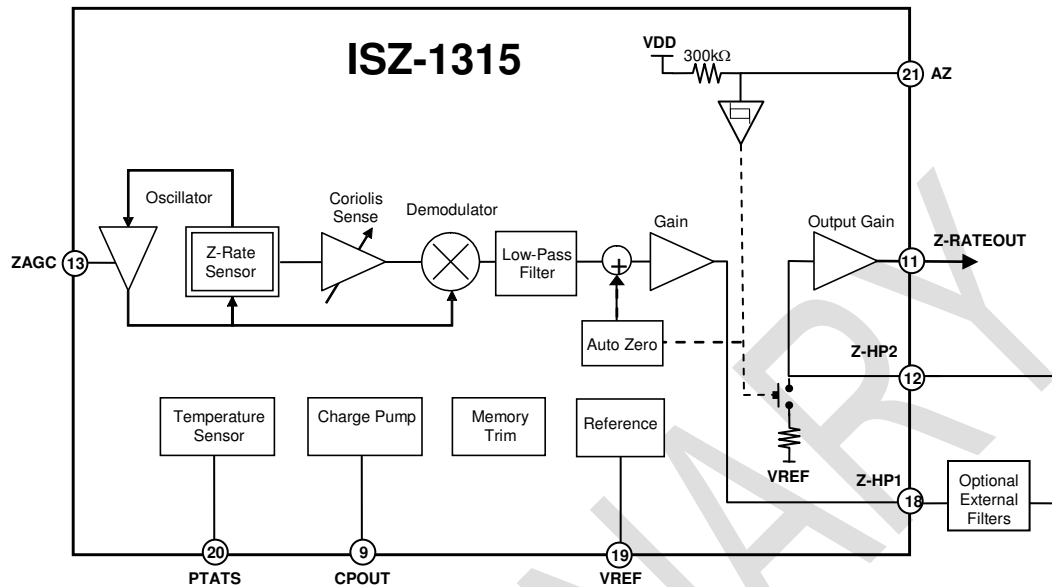

Figure 1

6. Functional Description

6.1 Overview

The ISZ-1315 gyroscope consists of a dual-mass, vibratory MEMS gyroscope. The gyroscope measures rotation rate about the Z-axis, the axis normal to the surface of the package.

The gyroscope's proof-masses are electrostatically oscillated at resonance. An internal automatic gain control circuit precisely controls the oscillation of the proof masses. When the sensor is rotated about the Z-axis, the Coriolis Effect causes a vibration that can be detected by a capacitive pickoff. The resulting signal is amplified, demodulated, and filtered to produce an analog voltage that is proportional to the angular rate.

6.2 Rate Sensor

The mechanical structure for detecting angular rate about the Z-axis is fabricated using InvenSense's proprietary bulk silicon technology. The structure is covered and hermetically sealed at the wafer level. The cover shields the gyro from electromagnetic and radio frequency interferences (EMI/RFI). The dual-mass design inherently rejects any signal caused by linear acceleration.

6.3 Oscillator Circuit

The oscillator circuit generates electrostatic forces to vibrate the structure at resonance. The circuit detects the vibration by measuring the capacitance between the oscillating structure and a fixed electrode. The oscillator circuit switches in quadrature phase with the capacitance measurement in order to vibrate at resonance.

6.4 Amplitude Control

The scale factor of the gyroscope depends on the amplitude of the mechanical motion and the trim setting of the internal programmable gain stages. The oscillation circuit precisely controls the amplitude to maintain constant sensitivity over the operating temperature range.



6.5 Coriolis Sense

Rotating the sensor about the Z-axis results in a Coriolis force on the Z-rate sensor. The Coriolis force causes the mechanical structure to vibrate in-plane. The resulting vibration is detected by measuring the capacitance change between the mechanical structure and fixed electrodes. This signal is converted to a voltage waveform by means of low-noise charge integrating amplifier and amplification stages.

6.6 Demodulator

The output of the Coriolis sense is an amplitude modulated waveform. The amplitude corresponds to the rotation rate, and the carrier frequency is the mechanical drive frequency. The synchronous demodulator converts the Coriolis sense waveform to the low-frequency, angular rate signal.

6.7 Low-Pass Filter

After the demodulation stage, there is a low-pass filter. This filter attenuates noise and high frequency artifacts before final amplification.

6.8 High-Pass Filter

Use of an external high-pass filter is recommended in order to minimize DC rate offset variation over temperature. The high-pass filter can be implemented with external passive components or digitally.

6.9 High-Pass Filter Reset Switch

An integrated switch can be used to reset an external high-pass filter. It may be desirable to reset the high-pass filter's capacitor during power-up or after certain user-defined conditions.

6.10 Auto Zero

The Auto Zero function is used to reduce DC offset caused by bias drift without the need for an external high-pass filter. Pin 21 (AZ) is used to set the Auto Zero function, resetting the bias to approximately VREF. If the Auto Zero function is used, a high-pass filter should not be used.

6.11 Temperature Sensor

A built-in Proportional-To-Absolute-Temperature (PTAT) sensor provides temperature information on Pin 20.

6.12 Charge Pump

The on-chip charge pump generates the voltage required to oscillate the mechanical structure.

6.13 Memory Trim

The on-chip memory is used to select the gyro's sensitivity, calibrate the sensitivity, null DC offsets and select the low-pass filter option

6.14 Scale Factor

The Rate-Out of the gyro is not ratiometric to the supply voltage. The scale factor is calibrated at the factory and is nominally independent of supply voltage.

6.15 Reference Voltage

The gyro includes a bandgap reference circuit. The output voltage is typically 1.35V and is nominally independent of temperature. The zero-rate signal is nominally equal to the reference value.



**ISZ-1315 Single-Axis Z-Gyroscope
Product Specification**

PS-ISZ-1315B-00-01
Release Date: 09/22/11

7. Specification

7.1 Specified Parameters

All parameters specified are @ VDD = 3.0 V and T_A = 25°C.

PARAMETER	CONDITIONS	MIN	TYP	MAX	UNITS	
SENSITIVITY						
Full-Scale Range			±67		%s	
Sensitivity			15		mV/%s	
Initial Calibration Tolerance			±6		%	
Calibration Drift Over Specified Temperature			±10		%	
Nonlinearity	Best Fit Straight Line		0.5		% of FS	
Cross-axis Sensitivity			±1		%	
REFERENCE						
Voltage (VREF)			1.35		V	
Tolerance			±50		mV	
Load Drive			100		µA	
Capacitive Load Drive	Load directly connected to VREF		100		pF	
Power Supply Rejection	VDD= 2.7V to 3.3V		1		mV/V	
Reference Drift Over Specified Temperature			±5		mV	
ZERO-RATE OUTPUT (ZRO)						
Static Output (Bias)	Factory Set		1.35		V	
Initial Calibration Tolerance	Relative to VREF	With Auto Zero	±20		mV	
		Without Auto Zero	±200			
ZRO Drift Over Specified Temperature			±50		mV	
Power Supply Sensitivity	@ 50 Hz		10		%sec/V	
FREQUENCY RESPONSE						
High Frequency Cutoff	Internal LPF -90°		140		Hz	
LPF Phase Delay	10Hz		-4.5		°	
MECHANICAL FREQUENCY						
Z-Axis Resonant Frequency		26	30	34	kHz	
NOISE PERFORMANCE						
Total RMS Noise	Bandwidth 1Hz to 1kHz		3		mV rms	
OUTPUT DRIVE CAPABILITY						
Output Voltage Swing	Load = 100kΩ to VDD/2	0.05		VDD-0.05	V	
Capacitive Load Drive			100			pF
Output Impedance			200			
POWER ON-TIME						
Zero-Rate Output	Settling to ±3% _s		50	200	ms	
AUTO ZERO / HPF CONTROL SWITCH (AZ)						
AZ Logic High	Rising Input		1.9		V	
AZ Logic Low	Falling Input		0.9		V	
HPF Reset Pulse Duration	Time AZ is logic high	3			msec	
Auto Zero Pulse Duration	Time AZ is logic high	2		1500	µsec	
Offset Settle Time after Auto-Zero			7		msec	
HPF Switch Resistance			650		Ω	



ISZ-1315 Single-Axis Z-Gyroscope Product Specification

PS-ISZ-1315B-00-01
Release Date: 09/22/11

7.2 Specified Parameters, continued

All parameters specified are @ VDD = 3.0 V and T_A = 25°C.

PARAMETER	CONDITIONS	MIN	TYP	MAX	UNITS
POWER SUPPLY (VDD) Operating Voltage Range Quiescent Supply Current Supply Current Change Over Specified Temperature		2.7	3.0 4.5 ±1	3.3	V mA mA
TEMPERATURE SENSOR Sensitivity Offset Output Impedance	Range -20 to +85°C		4 1.25 12		mV/°C V kΩ
TEMPERATURE RANGE Specified Temperature Range		-20		+85	°C

7.3 Recommended Operating Conditions

Parameter	Min	Typ	Max	Unit
Power Supply Voltage (VDD)	2.7	3.0	3.3	V
Power Supply Voltage (VDD) Rise Time (10% - 90%)			20	ms

7.4 Absolute Maximum Ratings

Stress above those listed as “Absolute Maximum Ratings” may cause permanent damage to the device. This is a stress rating only and functional operation of the device under these conditions is not implied. Exposure to the absolute maximum rating conditions for extended periods may affect device reliability.

Parameter	Rating
Supply Voltage	-0.3V to +3.6V
Acceleration (Any Axis, unpowered)	10,000g for 0.3ms
Operating Temperature Range	-40 to +105°C
Storage Temperature Range	-40 to +125°C

7.5 Reference Circuit

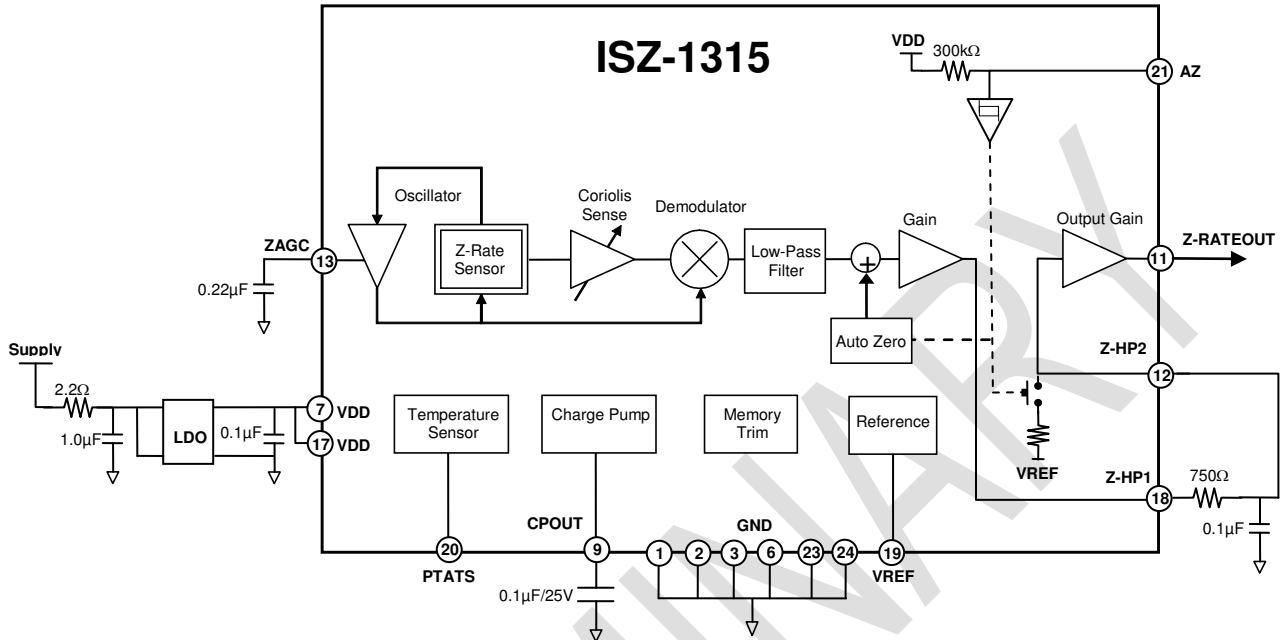

Figure 2

Bill of Material for External Components

Component	Specification
Low Pass Filter Capacitor	0.1μF ±20% / 10V
AGC Capacitor	0.22μF ±10% / 10V
VDD Bypass Capacitor	0.1μF ±20% / 10V
Charge Pump Capacitor	0.1μF ±20% / 25V
LDO Input Filter Capacitor	1.0μF / Ratings Dependent upon Supply Voltage
LDO Input Filter Resistor	2.2Ω ±1%
Low Pass Filter Resistor	750Ω ±1%

8. Application Information

8.1 Pin Out and Signal Description

Number	Pin	Description
1, 2, 3, 6, 23, 24	GND	Ground
7, 17	VDD	Positive supply voltage
9	CPOUT	Charge pump capacitor connection
11	Z-RATEOUT	Z-axis output, analog voltage proportional to rotational rate ($\pm 67^\circ/\text{sec}$ FSR)
13	ZAGC	Amplitude control capacitor connection
12	Z-HP2	Z-axis input to the final output amplifier
18	Z-HP1	Output from first gain stage output amplifier
19	VREF	Voltage reference output
20	PTATS	Temperature sensor output
21	AZ	Auto Zero and high-pass filter (HPF) reset control pin. Pull low when not enabling auto zero or HPF reset.
8, 10, 16, 22	RESV	Reserved. Do not connect.
4, 5, 14, 15	NC	Not internally connected. May be used for PCB trace routing.

Top View

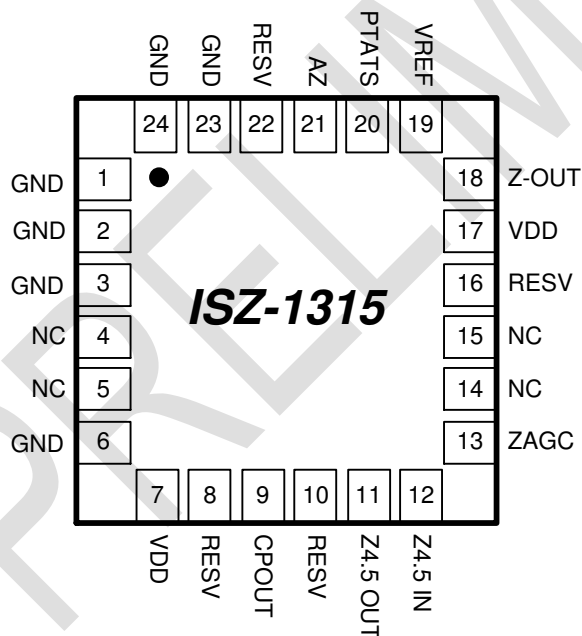

**24-pin, 4mm x 4mm x 0.9mm
QFN Package**

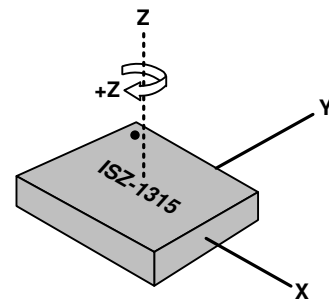

**Orientation of Axis of
Sensitivity and Polarity
of Rotation**

Figure 3

8.2 Design Considerations

8.2.1 Power Supply Rejection Ratio

The gyro is most susceptible to power supply noise (ripple) at frequencies less than 100Hz. At less than 100Hz, the PSRR is determined by the overall internal gain of the gyroscope. Above 100Hz, the PSRR is determined by the characteristics of the on-chip low-pass filter. Above 1kHz, the PSRR is relatively constant except for a narrow frequency range corresponding to the resonant frequency of the Z-gyroscope.

8.2.2 Power Supply Filtering

The Power Supply Voltage (VDD) rise time (10% - 90%) must be less than 20ms at VDD (Pins 7 and 17) for proper device operation.

The ISZ-1315 gyroscope should be isolated from system power supply noise by a combination of an RC filter that attenuates high frequency noise and a Low Drop Out linear regulator (LDO) that attenuates low frequency noise. Figure 4 shows a typical configuration.

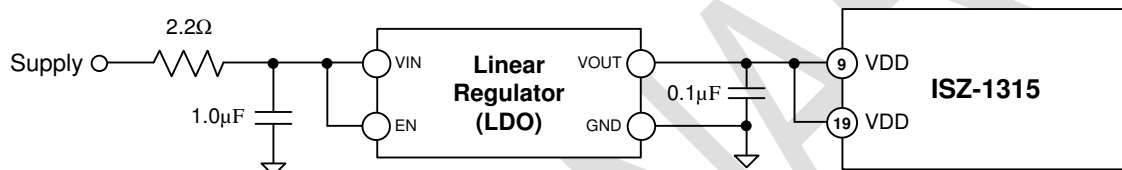

Figure 4

The low-pass RC filter should be chosen such that it provides significant attenuation of system noise at high frequencies. The LDO should be a low noise regulator ($<100\mu\text{V}/\text{rtHz}$) that exhibits good noise rejection at low frequencies.

8.2.3 Amplitude Control

The scale factor of the gyroscope depends on the amplitude of the mechanical motion and the trim setting of the internal programmable gain stages. The oscillation circuit precisely controls the amplitude to maintain constant sensitivity over the specified temperature range. The capacitor connected to Pin 13 (ZAGC) is a compensation capacitor for the amplitude control loop.

8.2.4 Temperature Sensor

A built-in Proportional-To-Absolute-Temperature (PTAT) sensor provides temperature information on Pin 20 (PTATS). The temperature sensor output signal is analog, and has a bias of approximately 1.25V at room temperature, and increases at a rate of $4\text{mV}/^\circ\text{C}$. The output impedance is nominally $12\text{k}\Omega$ and is therefore not designed to drive low impedance loads. If necessary, the output can be externally buffered with a low offset-drift buffer, and optionally a low-pass filter to minimize noise.

8.2.5 Internal Low-Pass Filter

After the demodulation stage, there is a low-pass filter. This filter limits noise and high frequency artifacts from the demodulator before final amplification. The following graph shows the typical gain and phase response. The low-pass filter has been designed for a nominally flat gain up to the cutoff frequency while still achieving a low phase delay at 10Hz and 30Hz.

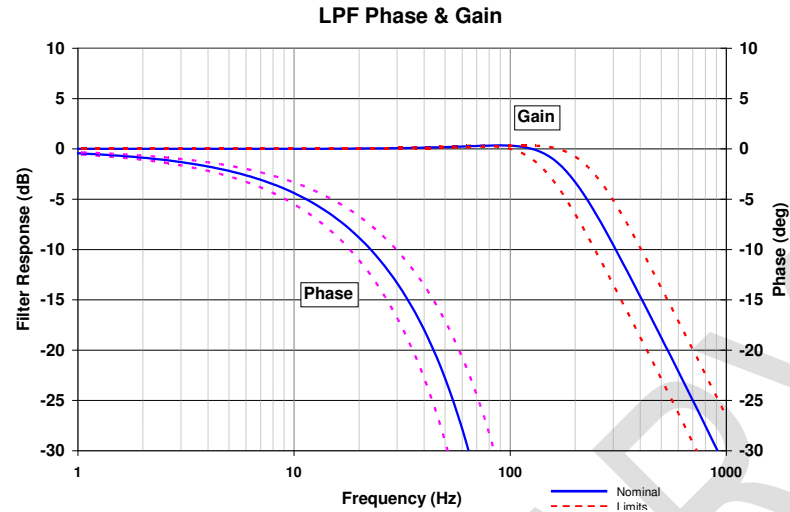

Figure 5

8.2.6 External Low-Pass Circuitry

To further attenuate high-frequency noise, an optional external low-pass filter may be used.

8.2.7 High-Pass Filter

A high-pass filter is used to minimize DC rate offset variation (ZRO shift) due to temperature. The high-pass filter is implemented by connecting an RC combination between Z-HP1 and Z-HP2. The cut-off frequency for the filter is defined by $f_{\text{cutoff}} = 1/2\pi RC$. The following table shows examples of HPF configurations.

Cut-off Frequency (Hz)	Resistor (kΩ)	Capacitor (μF)
0.03	1000	4.7
0.1	330	4.7
0.3	330	1.5

8.2.8 High-Pass Filter Reset

The ISZ-1315 gyroscope circuitry includes an integrated switch to reset the external high-pass filter (HPF), if one is used. The switch is activated by bringing the AZ pin (Pin 24) high. This closes the reset switch and shorts the high-pass filter capacitor at Z-HP2 to VREF, allowing the capacitor to charge up quickly. Without the high-pass filter reset switch, the high-pass filter can take several seconds to initialize. It is recommended to reset the high-pass filter at startup and during overload conditions. The AZ Pin has an internal pull-up resistor of 300kΩ. During normal operation, the AZ pin should be pulled low. Note that the AZ input buffer is a Schmitt buffer with approximately 1.0V of hysteresis.

8.2.9 Auto Zero

Auto Zero is a function that reduces the effect of Zero Rate Offset drift without the need for an external high-pass filter. If the Auto Zero function is used, a high-pass filter should not be used.

AZ works by keeping the gyro's Zero-Rate Output (ZRO) close to VREF, and thus allows the user to achieve a wider usable signal range, without using an external analog high pass filter.

When activated, the Auto Zero circuit internally nulls the ZRO to approximately VREF. The typical usage of Auto Zero is in conditions where:

1. The gyro's motion is known, such as when:
 - a. The gyro is stationary.
 - b. Other sensors can report angular rotation rate.
2. The DC value of the gyro output is not important, but only the AC value is. In this case, a digital ac filter may be used to extract the gyro data, which provides a higher-quality output than is possible with an analog R-C filter.

The Auto Zero function is initiated on the rising edge of the AZ pin. The Auto Zero settling time is typically 7ms. This time includes the time required for nulling the ZRO and for the settling of the internal low pass filter (LPF). If the external LPF bandwidth is less than 200Hz, the Auto Zero settling time will be longer than specified.

The AZ pulse width should meet the specified minimum time requirement of 2 μ s to start the Auto Zero function, and should be shorter than the maximum specified time of 1,500 μ s. The Auto Zero pulse should occur after the start-up period to cancel any initial calibration error.

8.2.10 High Impedance Nodes

The ZAGC pin is a high impedance node (>1Mohm). Any coating, glue or epoxy on this pin or on the capacitor connected to this pin, will affect part performance and should be avoided.

8.2.11 Charge Pump

The on-chip charge pump requires a capacitor for stable operation. This capacitor should be 0.1 μ F and rated for 25V.

8.2.12 Proper Interface Cleaning

Proper cleaning of PCB solder pads prior to assembly is recommended. PCB surface contaminants at pin 13 may affect part performance.

8.2.13 Acoustic Noise Sensitivity

The ISZ-1315 gyroscope is insensitive to vibration except for a narrow frequency range near the gyro's resonant frequency and at odd multiples of the resonant frequency. The typical bandwidth of the acoustic sensitivity is 200Hz. It is recommended that products using the ISZ-1315 gyroscope along with mechanical actuators be designed such that the acoustic noise in the 20kHz to 31kHz range be attenuated by the product's enclosure avoids these frequency ranges.

8.2.14 Electrostatic Discharge Sensitivity

The ISZ-1315 gyroscope can be permanently damaged by an electrostatic discharge. ESD precautions for handling and storage are recommended.

9. Assembly

This section provides general guidelines for assembling InvenSense Micro Electro-Mechanical Systems (MEMS) gyros packaged in Quad Flat No leads package (QFN) surface mount integrated circuits.

9.1 Orientation of Axes

The diagram below shows the orientation of the axis of sensitivity and the polarity of rotation. Note the pin 1 identifier in the figure.

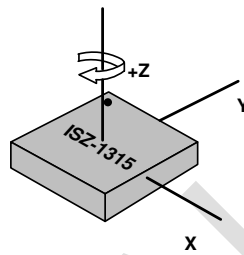

Orientation of Axis of Sensitivity and Polarity of Rotation

9.2 Package Dimensions:

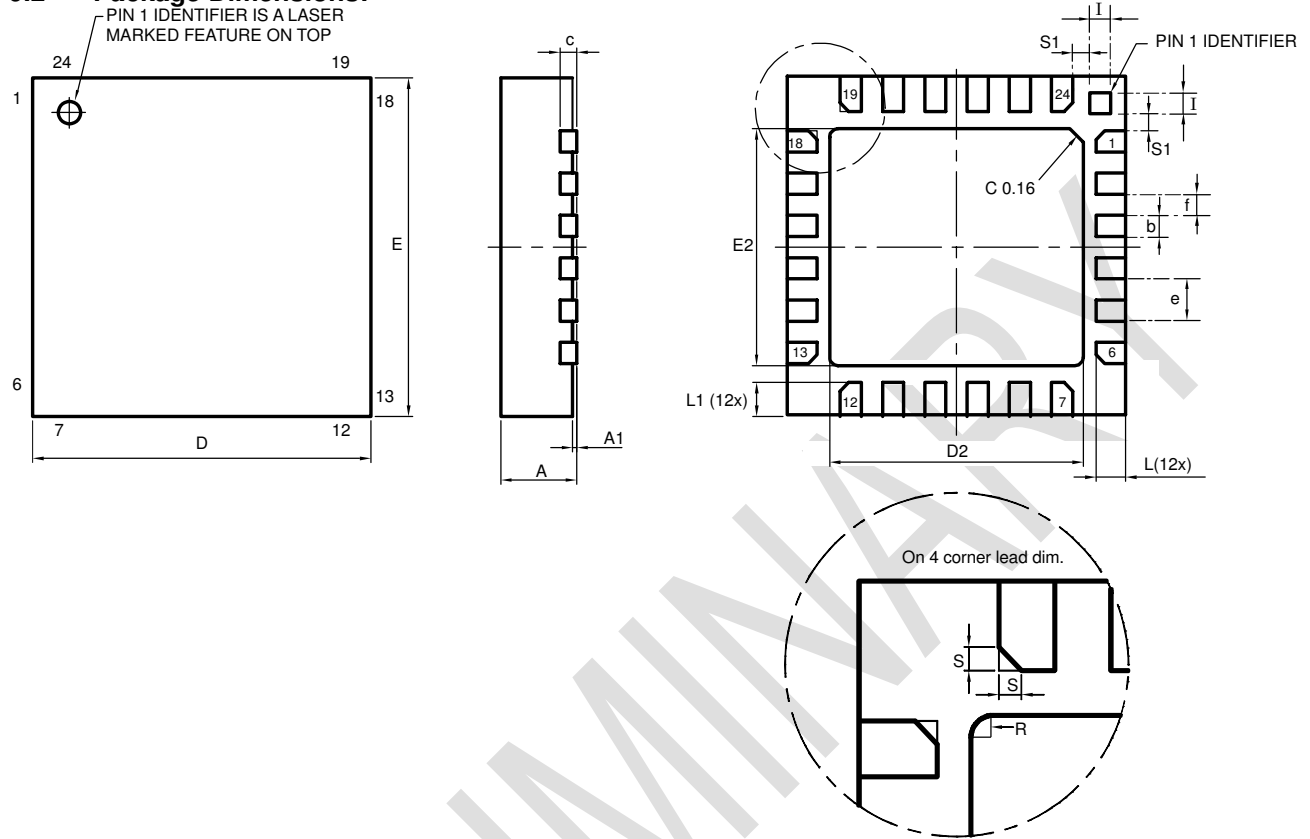

SYMBOLS	DIMENSIONS IN MILLIMETERS		
	MIN	NOM	MAX
A	0.85	0.90	0.95
A1	0.00	0.02	0.05
b	0.18	0.25	0.30
c	---	0.20 REF.	---
D	3.90	4.00	4.10
D2	2.95	3.00	3.05
E	3.90	4.00	4.10
E2	2.75	2.80	2.85
e	---	0.50	---
f (e-b)	0.20	0.25	0.32
L	0.30	0.35	0.40
L1	0.35	0.40	0.45
I	0.20	0.25	0.30
R	0.05	---	0.10
s	0.05	---	0.15
S1	0.15	0.20	0.25

9.3 PCB Design Guidelines:

The Pad Diagram using a JEDEC type extension with solder rising on the outer edge is shown below. The Pad Dimensions Table shows pad sizing (mean dimensions) recommended for the ISZ-1315 product.

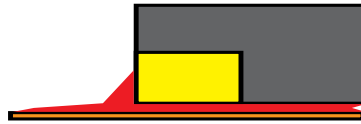

JEDEC type extension with solder rising on outer edge

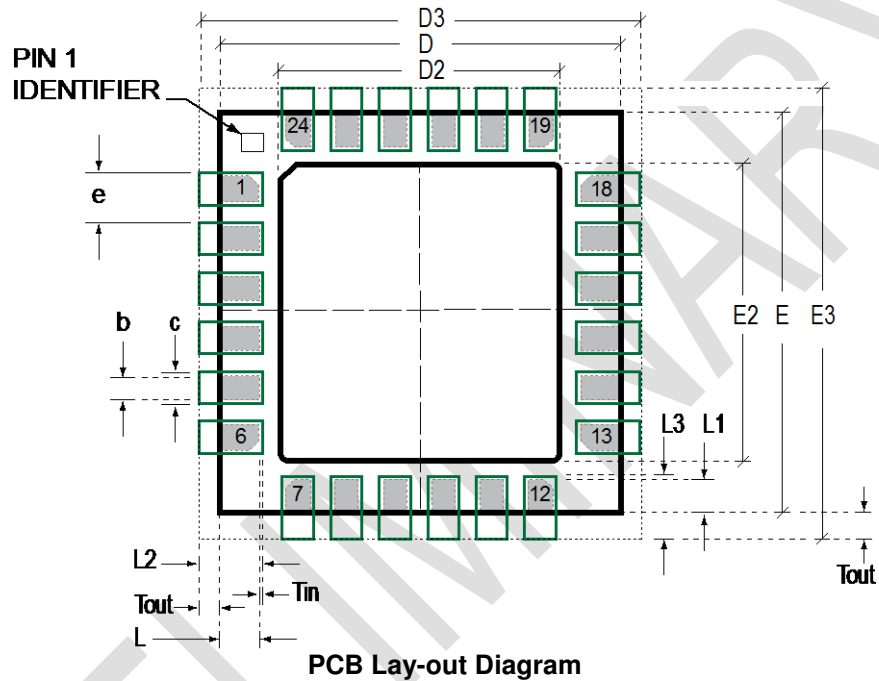

SYMBOLS	DIMENSIONS IN MILLIMETERS	NOM
Nominal Package I/O Pad Dimensions		
e	Pad Pitch	0.50
b	Pad Width	0.25
L	Pad Length	0.35
L1	Pad Length	0.40
D	Package Width	4.00
E	Package Length	4.00
D2	Exposed Pad Width	3.00
E2	Exposed Pad Length	2.80
I/O Land Design Dimensions (Guidelines)		
D3	I/O Pad Extent Width	4.80
E3	I/O Pad Extent Length	4.80
c	Land Width	0.35
Tout	Outward Extension	0.40
Tin	Inward Extension	0.05
L2	Land Length	0.80

	ISZ-1315 Single-Axis Z-Gyroscope Product Specification	PS-ISZ-1315B-00-01 Release Date: 09/22/11
---	---	--

L3	Land Length	0.85
----	-------------	------

PCB Dimensions Table (for PCB Lay-out Diagram)

9.4 Assembly Precautions

9.4.1 Gyroscope Surface Mount Guidelines

InvenSense MEMS Gyros sense rate of rotation. In addition, gyroscopes sense mechanical stress coming from the printed circuit board (PCB). This PCB stress can be minimized by adhering to certain design rules:

When using MEMS gyroscope components in plastic packages, PCB mounting and assembly can cause package stress. This package stress in turn can affect the output offset and its value over a wide range of temperatures. This stress is caused by the mismatch between the Coefficient of Linear Thermal Expansion (CTE) of the package material and the PCB. Care must be taken to avoid package stress due to mounting.

Traces connected to pads should be as symmetric as possible. Maximizing symmetry and balance for pad connection will help component self alignment and will lead to better control of solder paste reduction after reflow.

Any material used in the surface mount assembly process of the MEMS gyroscope should be free of restricted RoHS elements or compounds. Pb-free solders should be used for assembly.

9.4.2 Exposed Die Pad Precautions

The ISZ-1315 has very low active and standby current consumption. The exposed die pad is not required for heat sinking, and should not be soldered to the PCB. Failure to adhere to this rule can induce performance changes due to package thermo-mechanical stress. There is no electrical connection between the pad and the CMOS.

9.4.3 Trace Routing

Routing traces or vias under the gyro package such that they run under the exposed die pad is prohibited. Routed active signals may harmonically couple with the gyro MEMS devices, compromising gyro response. These devices are designed with the drive frequency of $Z=30\pm 4\text{kHz}$. To avoid harmonic coupling don't route active signals in non-shielded signal planes directly below, or above the gyro package. Note: For best performance, design a ground plane under the e-pad to reduce PCB signal noise from the board on which the gyro device is mounted. If the gyro device is stacked under an adjacent PCB board, design a ground plane directly above the gyro device to shield active signals from the adjacent PCB board.

9.4.4 Component Placement

Do not place large insertion components such as keyboard or similar buttons, connectors, or shielding boxes at a distance of less than 6 mm from the MEMS gyro. Maintain generally accepted industry design practices for component placement near the ISZ-1315 to prevent noise coupling and thermo-mechanical stress.

9.4.5 PCB Mounting and Cross-Axis Sensitivity

Orientation errors of the gyroscope mounted to the printed circuit board can cause cross-axis sensitivity in which one gyro responds to rotation about another axis, for example, the Z-axis gyroscope responding to rotation about the X or Y axes. The orientation mounting errors are illustrated in the figure below.

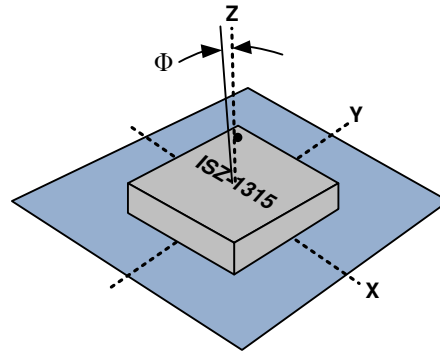

Package Gyro Axes (.....) Relative to PCB Axes (———) with Orientation Error (Φ)

Figure 10

The table below shows the cross-axis sensitivity of the gyroscope for a given orientation error.

Cross-Axis Sensitivity vs. Orientation Error

Orientation Error (θ or Φ)	Cross-Axis Sensitivity ($\sin\theta$ or $\sin\Phi$)
0°	0%
0.5°	0.87%
1°	1.75%

The specification for cross-axis sensitivity in Section 7.1 includes the effect of the die orientation error with respect to the package.

9.4.6 MEMS Handling Instructions

MEMS (Micro Electro-Mechanical Systems) are a time-proven, robust technology used in hundreds of millions of consumer, automotive and industrial products. MEMS devices consist of microscopic moving mechanical structures. They differ from conventional IC products, even though they can be found in similar packages. Therefore, MEMS devices require different handling precautions than conventional ICs prior to mounting onto printed circuit boards (PCBs).

The ISZ-1315 gyroscope has been qualified to a shock tolerance of 10,000g. InvenSense packages its gyroscopes as it deems proper for protection against normal handling and shipping. It recommends the following handling precautions to prevent potential damage.

- Do not drop individually packaged gyroscopes, or trays of gyroscopes onto hard surfaces. Components placed in trays could be subject to *g*-forces in excess of 10,000g if dropped.
- Printed circuit boards that incorporate mounted gyroscopes should not be separated by manually snapping apart. This could also create *g*-forces in excess of 10,000g.

9.4.7 ESD Considerations

Establish and use ESD-safe handling precautions when unpacking and handling ESD-sensitive devices.

- Store ESD sensitive devices in ESD safe containers until ready for use. The Tape-and-Reel moisture-sealed bag is an ESD approved barrier. The best practice is to keep the units in the original moisture sealed bags until ready for assembly.

- Restrict all device handling to ESD protected work areas that measure less than 200V static charge. Ensure that all workstations and personnel are properly grounded to prevent ESD.

9.4.8 Reflow Specification

Qualification Reflow: The ISZ-1315 gyroscope was qualified in accordance with IPC/JEDEC J-STD-020D.01. This standard classifies proper packaging, storage and handling in order to avoid subsequent thermal and mechanical damage during the solder reflow attachment phase of assembly. The classification specifies a sequence consisting of a bake cycle, a moisture soak cycle in a temperature humidity oven, followed by three solder reflow cycles and functional testing for qualification. All temperatures refer to the top side of the QFN package, as measured on the package body surface. The peak solder reflow classification temperature requirement is (260 +5/-0 °C) for lead-free soldering of components measuring less than 1.6 mm in thickness.

Production Reflow: Check the recommendations of your solder manufacturer. For optimum results, production solder reflow processes should reduce exposure to high temperatures, and use lower ramp-up and ramp-down rates than those used in the component qualification profile shown for reference below.

Production reflow should never exceed the maximum constraints listed in the table and shown in the figure below. These constraints were used for the qualification profile, and represent the maximum tolerable ratings for the device.

Maximum Temperature IR / Convection Solder Reflow Curve Used for Qualification

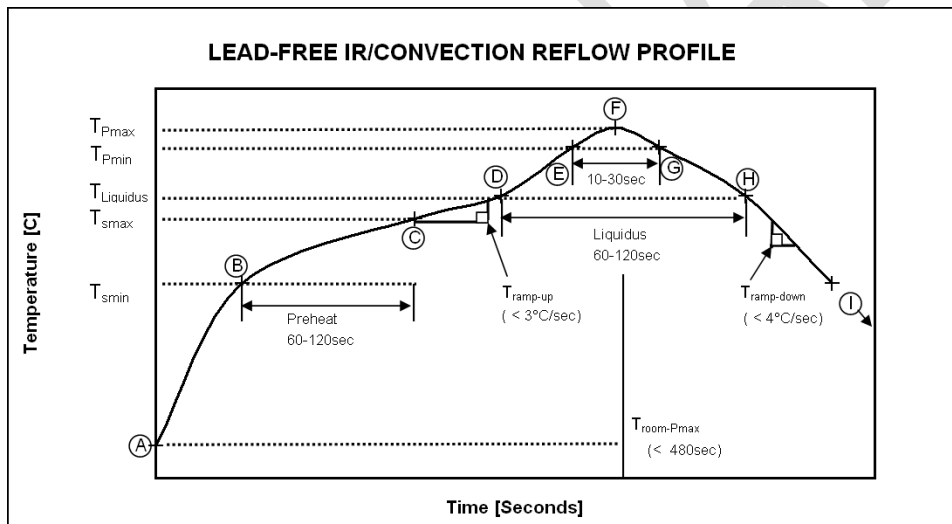

Temperature Set Points for IR / Convection Reflow Corresponding to Figure Above

Step	Setting	CONSTRAINTS		
		Temp (°C)	Time (sec)	Rate (°C/sec)
A	T _{room}	25		
B	T _{Smin}	150		
C	T _{Smax}	200	60 < t _{BC} < 120	
D	T _{Liquidus}	217		r(T _{Liquidus} -T _{Pmax}) < 3
E	T _{Pmin} [255°C, 260°C]	255		r(T _{Liquidus} -T _{Pmax}) < 3
F	T _{Pmax} [260°C, 265°C]	260	t _{AF} < 480	r(T _{Liquidus} -T _{Pmax}) < 3
G	T _{Pmin} [255°C, 260°C]	255	10 < t _{EG} < 30	r(T _{Pmax} -T _{Liquidus}) < 4
H	T _{Liquidus}	217	60 < t _{DH} < 120	
I	T _{room}	25		

Note: For users T_{Pmax} must not exceed the classification temperature (260 °C).

For suppliers T_{Pmax} must equal or exceed the classification temperature.

9.5 Storage Specifications

The storage specification of the ISZ-1315 gyroscope conforms to IPC/JEDEC J-STD-020D.01 Moisture Sensitivity Level (MSL) 3.

Calculated shelf-life in moisture-sealed bag	12 months -- Storage conditions: <40°C and <90% RH
After opening moisture-sealed bag	168 hours -- Storage conditions: ambient ≤30°C at 60%RH

9.6 Package Marking Specification

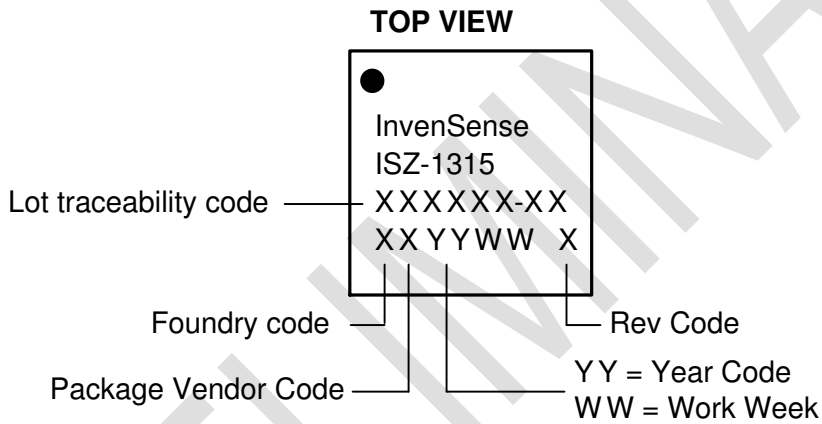

Package Marking Specification

9.7 Tape & Reel Specification

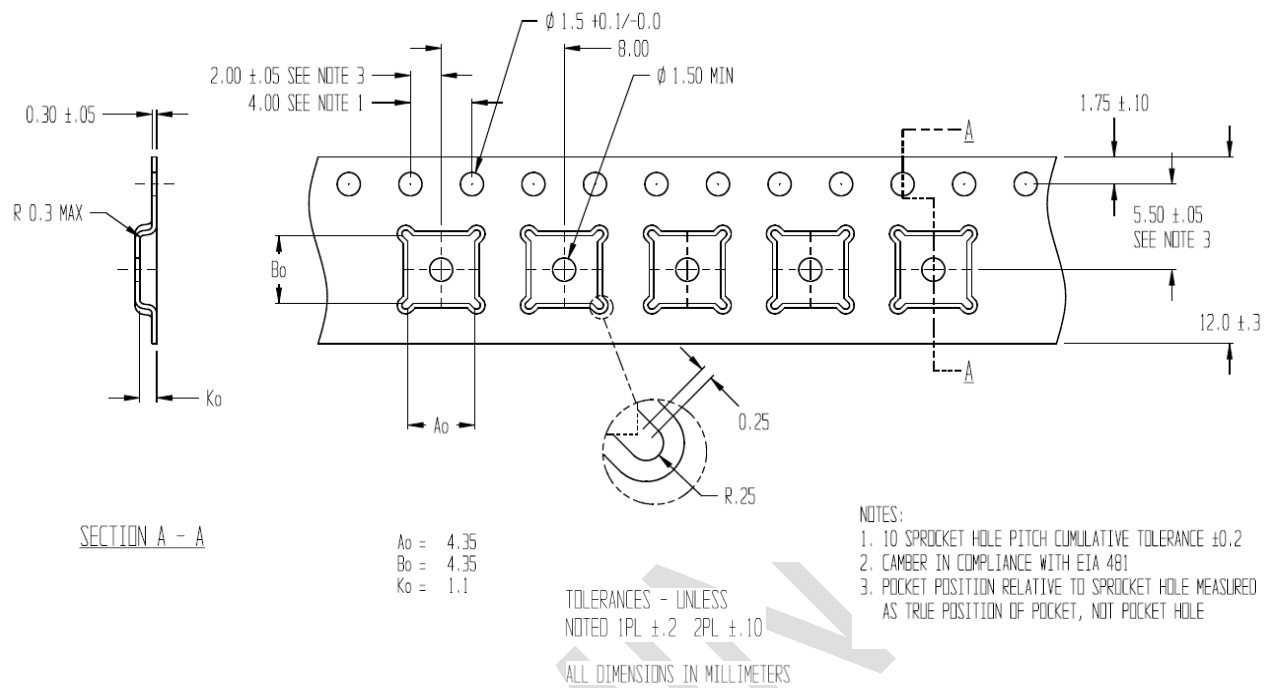

Tape Dimensions

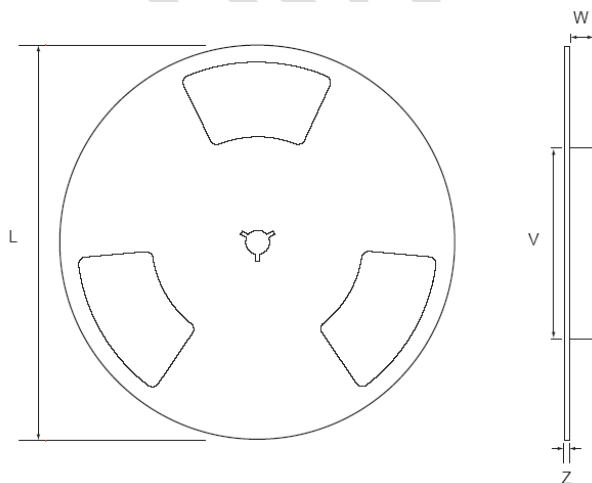

Reel Outline Drawing

Reel Dimensions and Package Size

PACKAGE SIZE	REEL (mm)			
	L	V	W	Z
4x4	330	100	13.2	2.2

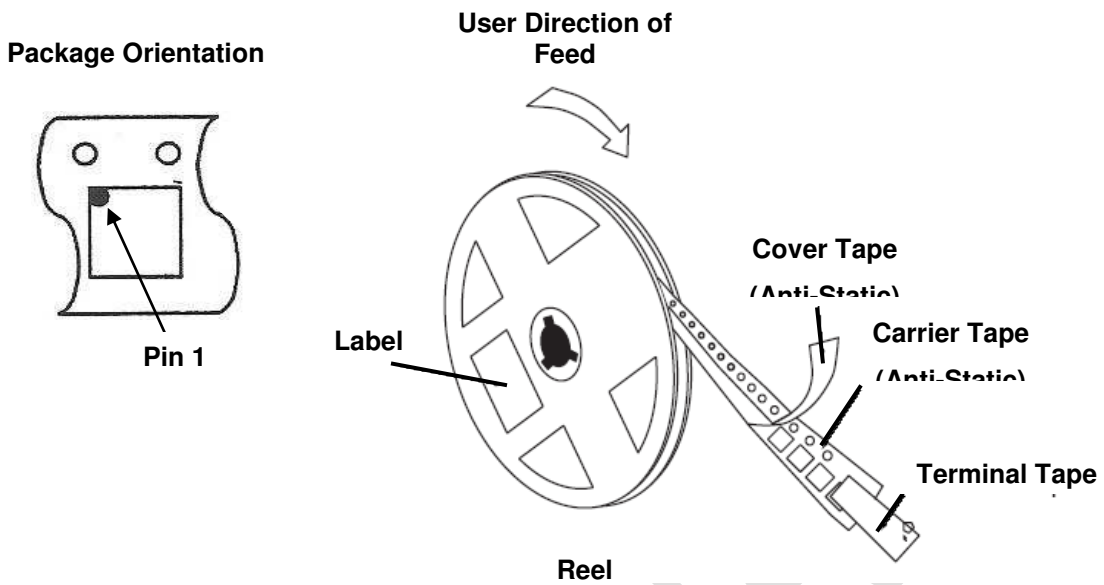

Tape and Reel Specification

Reel Specifications

Quantity Per Reel	5,000
Reels per Box	1
Boxes Per Carton (max)	3
Pieces per Carton (max)	15,000

9.8 Label

InvenSense		
DEVICE (IP) : ISZ-1315 P.O:		REEL QTY (Q) : 5000
LOT 1 (IT) : 123456-A	D/C (D) : 1234	QTY (Q) : 5000
LOT 2 (IT) :	D/C (D) :	QTY (Q) :
Reel Date : 13/10/09		QC STAMP



Location of Label

9.9 Packaging

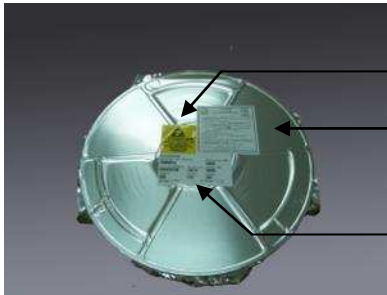

**Moisture Barrier Bag
With Labels**

- ESD Anti-static Label
- Moisture-Sensitivity
- Caution Label
- Tape & Reel
- Barcode Label

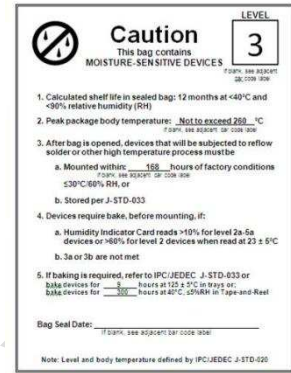

Moisture-Sensitive Caution Label



Reel in Box



Box with Tape & Reel Label

PRELIMINARY

	ISZ-1315 Single-Axis Z-Gyroscope Product Specification	PS-ISZ-1315B-00-01 Release Date: 09/22/11
---	---	--

10. Reliability

10.1 Qualification Test Policy

InvenSense's products complete a Qualification Test Plan before being released to production. The Qualification Test Plan follows the JEDEC 47D Standards, "Stress-Test-Driven Qualification of Integrated Circuits," with the individual tests described below.

10.2 Qualification Test Plan

Accelerated Life Tests

Test	Method/Condition	Lot Quantity	Samples / Lot	Accept / Reject Criteria
High Temperature Operating Life (HTOL/LFR)	JEDEC JESD22-A108C, Dynamic, 3.63V biased, T _j >125°C [read-points 168, 500, 1000 hours]	3	77	(1/2)
Steady-State Temperature Humidity Unbiased Life ⁽¹⁾	JEDEC JESD22-A101C, 85°C/85%RH [read-points 168, 500, 1000 hours]	3	77	(1/2)
High Temperature Storage Life	JEDEC JESD22-A103C, Cond. A, 125°C Non-Bias Bake [read-points 168, 500, 1000 hours]	3	77	(1/2)

Device Component Level Tests

Test	Method/Condition	Lot Quantity	Samples / Lot	Accept / Reject Criteria
ESD-HBM	JEDEC JESD22-A114F, Class 2 (2KV)	1	15	(0/1)
ESD-MM	JEDEC JESD22-A115-A, Class B (200V)	1	12	(0/1)
Latch Up	JEDEC JESD78B Class 1 (25°C), Level 1 (+/- 100mA)	1	6	(0/1)
Mechanical Shock	JEDEC JESD22-B104C, Mil-Std-883, method 2002, Cond. D, 10,000g's, 0.3ms, ±X,Y,Z – 6 directions, 5 times/direction	3	5	(0/1)
Vibration	JEDEC JESD22-B103B, Variable Frequency (random), Cond. B, 5-500Hz, X,Y,Z – 4 times/direction	3	5	(0/1)
Temperature Cycling ⁽¹⁾	JEDEC JESD22-A104D Condition N, -40°C to +85°C, Soak Mode 2, 100 cycles	3	77	(1/2)

(1) Tests are preceded by MSL3 Preconditioning in accordance with JEDEC JESD22-A113F

	ISZ-1315 Single-Axis Z-Gyroscope Product Specification	PS-ISZ-1315B-00-01 Release Date: 09/22/11
---	---	--

11. Environmental Compliance

The ISZ-1315 is RoHS and Green compliant.

The ISZ-1315 is in full environmental compliance as evidenced in report HS-ISZ-1315B, Materials Declaration Data Sheet.

Environmental Declaration Disclaimer:

InvenSense believes this environmental information to be correct but cannot guarantee accuracy or completeness. Conformity documents for the above component constitutes are on file. InvenSense subcontracts manufacturing and the information contained herein is based on data received from vendors and suppliers, which has not been validated by InvenSense.

PRELIMINARY



**ISZ-1315 Single-Axis Z-Gyroscope
Product Specification**

PS-ISZ-1315B-00-01
Release Date: 09/22/11

This information furnished by InvenSense is believed to be accurate and reliable. However, no responsibility is assumed by InvenSense for its use, or for any infringements of patents or other rights of third parties that may result from its use. Specifications are subject to change without notice. InvenSense reserves the right to make changes to this product, including its circuits and software, in order to improve its design and/or performance, without prior notice. InvenSense makes no warranties, neither expressed nor implied, regarding the information and specifications contained in this document. InvenSense assumes no responsibility for any claims or damages arising from information contained in this document, or from the use of products and services detailed therein. This includes, but is not limited to, claims or damages based on the infringement of patents, copyrights, mask work and/or other intellectual property rights.

Certain intellectual property owned by InvenSense and described in this document is patent protected. No license is granted by implication or otherwise under any patent or patent rights of InvenSense. This publication supersedes and replaces all information previously supplied. Trademarks that are registered trademarks are the property of their respective companies. InvenSense sensors should not be used or sold in the development, storage, production or utilization of any conventional or mass-destructive weapons or for any other weapons or life threatening applications, as well as in any other life critical applications such as medical equipment, transportation, aerospace and nuclear instruments, undersea equipment, power plant equipment, disaster prevention and crime prevention equipment.

InvenSense™ is a registered trademark of InvenSense, Inc. ISZ™ and ISZ-1315™ are trademarks of InvenSense, Inc.

©2011 InvenSense, Inc. All rights reserved.

