

Features:

- Frequency Range: 2-20 GHz
- P1 dB: +28 dBm
- Psat: +29 dBm
- Gain: 8.0dB
- Gain Flatness: +/- 1 dB
- Input/Output Return Loss: 10 dB
- Noise Figure: 4.5 dB
- MTTF > 100 years @ 85°C ambient temperature
- Chip Size: 2.58 X 1.05 X 0.10 mm

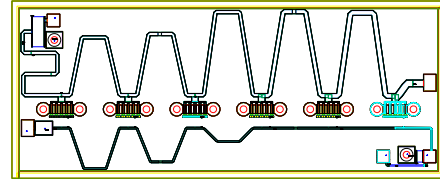

Applications:

- EW
- ECM
- Instrumentation

Description:

The MMA-022028 is a 2-20 GHz wideband MMIC distributed broadband power amplifier based on high reliability AlGaAs/InGaAs pHEMT technology. It provides more than 28 dBm output power at P-1dB, and 29 dBm at Psat. Small signal gain is typically 8.0 dB across the band. Input and output return loss is typically greater than 10 dB. This part can be used in broadband EW and instrumentation applications. Special screening for hi-rel and space applications is available.

Electrical Specifications: (Vds = 8.0V, Vgs = -0.65V, Ids=380mA, Zo=50 ohm, TA=25 °C)

Parameter	Units	Min.	Typ.	Max.
Frequency Range (Min/Max)	GHz	2		20
Small Signal Gain	dB	6.0	8.0	
Gain Flatness	+/-dB		1.0	
Input Return Loss	dB		-10	
Output Return Loss	dB		-10	
Output P1dB	dBm	+26.0	+28.0	
Output Saturation Power	dBm		+29.0	
Noise Figure	dB		4.5	
Operating Current Range (Min/Max)	mA	300	380	500
Thermal Resistance	°C/W		20	

Typical RF Performance: ($V_{ds} = 8.0V$, $I_{ds}=380mA$, $T_A=25^\circ C$, 50 Ohm system unless stated otherwise)

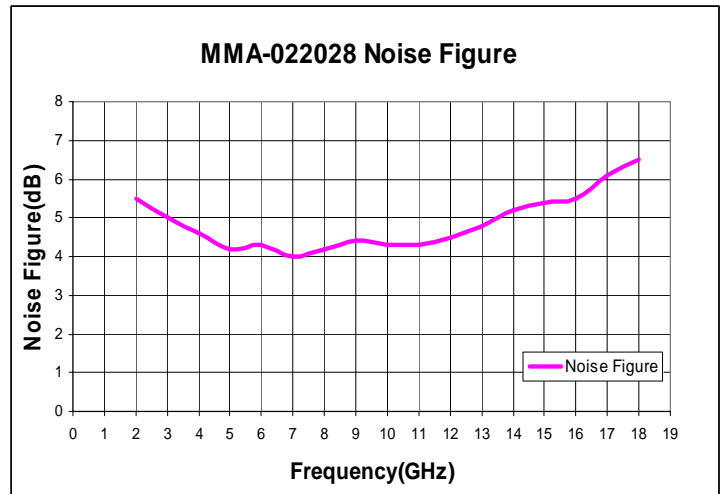
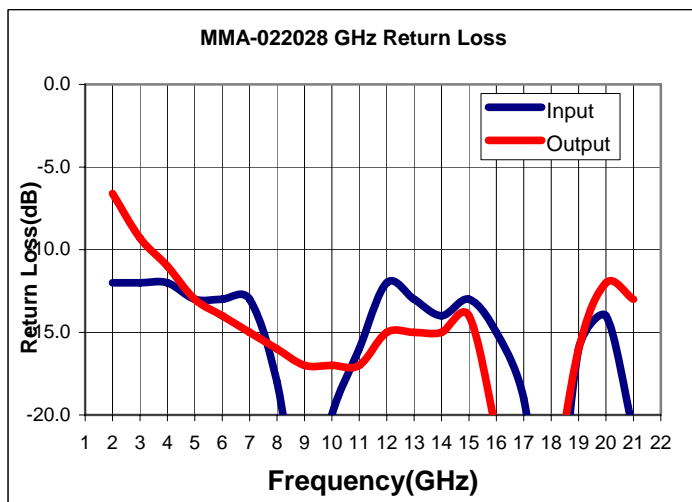
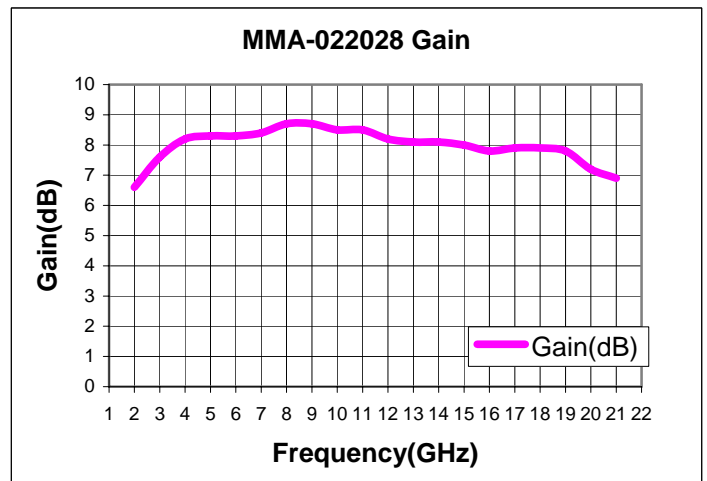
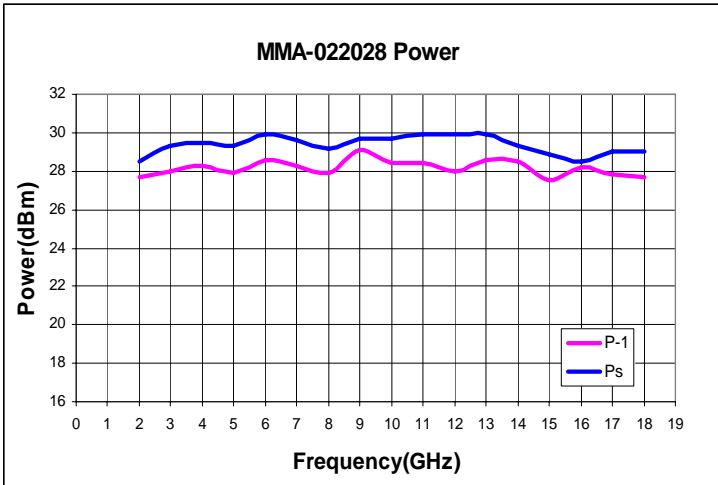

S-parameter: (V_{ds} = 8.0V, I_{ds}=380mA, T_A=25 °C, 50 Ohm system)

Freq(GHz)	S11(dB)	S11(ang)	S21(dB)	S21(ang)	S12(dB)	S12(ang)	S22(dB)	S22(ang)
2	-12.44	29.82	6.63	65.95	-40.44	21.29	-6.571	17.03
3	-12.08	-76.99	7.577	-14.32	-36.35	-67.39	-9.266	-78.32
4	-12.49	-178.8	8.177	-95.71	-33.9	-147.5	-11.22	-159.4
5	-12.7	68.24	8.316	-173.1	-32.25	135.7	-12.74	124.8
6	-12.56	-44.77	8.339	109	-31.04	58.37	-13.82	46.22
7	-13.36	-144.6	8.424	32.85	-30.22	-19.21	-15.07	-37.28
8	-17.98	111.6	8.713	-44.31	-29.19	-95.82	-16.39	-116.3
9	-27.42	-64.55	8.701	-122.1	-28.18	-173.1	-17.42	165.4
10	-19.55	126.8	8.54	159.6	-27.56	111.7	-17.48	77.05
11	-13.94	12.3	8.362	81.47	-26.76	35.75	-15.46	-9.927
12	-12.03	-82.63	8.131	3.532	-26.35	-36.51	-14.43	-89.32
13	-13.92	-149.3	8.088	-75.18	-25.77	-109.7	-15.21	-140
14	-13.72	164.3	8.217	-154.7	-25.41	174.3	-13.84	168
15	-13.85	87.52	7.646	126	-25.43	93.72	-16.31	94.91
16	-16.7	-5.015	7.93	44.57	-24.7	14.12	-25.9	10.83
17	-22.24	-104.1	7.907	-39.83	-24.3	-73.59	-27.36	-130.4
18	-22.12	-83.63	7.868	-127.7	-23.82	-160.8	-20.33	-173.2
19	-13.86	-176.5	7.217	142.6	-23.06	113.1	-13.15	122.4
20	-15.62	58.65	7.193	52.09	-22.41	26.89	-12.05	47.74
21	-26.5	-176.1	6.472	-48.4	-22.61	-63.75	-12.94	-13.57

Absolute Maximum Ratings (*):

SYMBOL	PARAMETER	UNITS	ABSOLUTE MAXIMUM
V _{ds}	Drain-Source Voltage	V	9.0
V _{gs}	Gate-Source Voltage	V	-2.0 to +0.8
I _{ds}	Drain Current	mA	600
I _{gs}	Gate Current	mA	3.0
P _{diss}	DC Power Dissipation	W	5.0
P _{in max}	RF Input Power	dBm	+25
T _{ch}	Channel Temperature	°C	150
T _{stg}	Storage Temperature	°C	-60 to 150

(*) Operation of this device above any one of these parameters may cause permanent damage.

Mechanical Diagram:

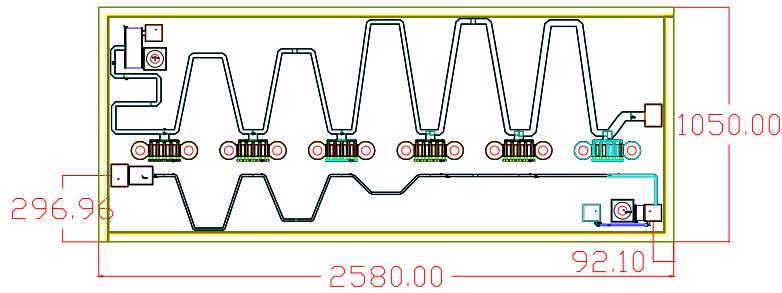

Unit: Microns

Application Information:

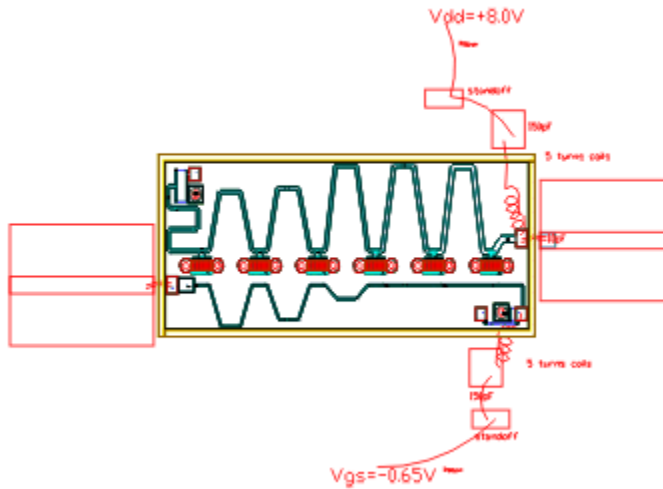

Notes: put 10 mils ridge underneath the MMIC chip to make MMIC same height with the circuit; make output bond short to improve the performance.