

Features:

- +27.0 dBm Output Power at 12 GHz
- 10.0 dB Small Signal Gain at 12 GHz
- 50 % PAE at 12 GHz
- 0.3 x 750 Micron Refractory Metal/Gold Gate
- Excellent for High Power, Gain, and High Power Added Efficiency Applications
- Ideal for Commercial, Military, Hi-Rel Space Applications

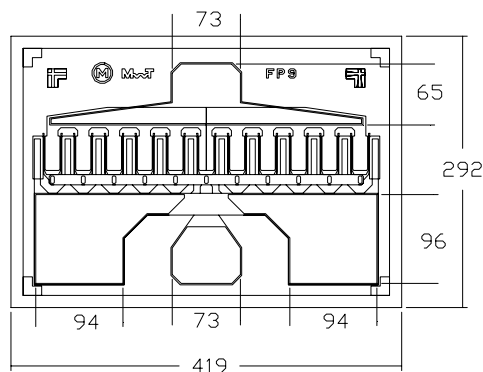

Chip Dimensions: 419 x 292 microns
Chip Thickness: 100 microns

Description:

The MwT-PH9 is a AlGaAs/InGaAs PHEMT (Pseudomorphic-High-Electron-Mobility-Transistor) device whose nominal 0.3 micron gate length and 750 micron gate width make it ideally suited for applications requiring high-gain and power up to 28 GHz frequency range with power outputs ranging from 400 to 500 milli-watts. The device is equally effective for either wideband (e.g. 6 to 18 GHz) or narrow-band applications. The chip is produced using MwT's reliable metal systems and all devices from each wafer are screened to insure reliability. All chips are passivated using MwT's patented "Diamond-Like Carbon" process for increased durability.

Electrical Specifications:

• at $T_a = 25\text{ }^\circ\text{C}$

SYMBOL	PARAMETERS & CONDITIONS	FREQ	UNITS	MIN	TYP
P1dB	Output Power at 1dB Compression $V_{ds}=7.0\text{ V}$ $I_{ds}=0.6 \times I_{DSS}=150\text{ mA}$	12 GHz	dBm	26.0	27.0
SSG	Small Signal Gain $V_{DS}=7.0\text{ V}$ $I_{ds}=0.6 \times I_{DSS}=150\text{ mA}$	12 GHz	dB	9.0	10.0
PAE	Power Added Efficiency at P1dB $V_{DS}=7.0\text{ V}$ $I_{ds}=0.6 \times I_{DSS}=150\text{ mA}$	12 GHz	%		50
IDSS	Recommended IDSS Range for Optimum P1dB		mA		120- 292

DC Specifications:

• at $T_a = 25\text{ }^\circ\text{C}$

SYMBOL	PARAMETERS & CONDITIONS	UNITS	MIN	TYP	MAX
IDSS	Saturated Drain Current $V_{ds}=4.0\text{ V}$ $V_{gs}=0.0\text{ V}$	mA	144		318
Gm	Transconductance $V_{ds}=2.5\text{ V}$ $V_{gs}=0.0\text{ V}$	mS	150	200	
Vp	Pinch-off Voltage $V_{ds}=3.0\text{ V}$ $I_{ds}=5.0\text{ mA}$	V		-1.2	-2.5
BVGSO	Gate-to-Source Breakdown Voltage $I_{gs} = -1.0\text{ mA}$	V	-6.0	-12.0	



MwT-PH9
28 GHz Medium Power AlGaAs/InGaAs PHEMT
Preliminary Data Sheet
May 2011

BVGDO	Gate-to-Drain Breakdown Voltage Igd= -1.0 mA	V	-10.0	-13.0
Rth	Chip Thermal Resistance	°C/W		56*

* Overall Rth depends on case mounting

MAXIMUM RATINGS AT Ta = 25 °C

Symbol	Parameter	Units	Cont Max1	Absolute Max2
VDS	Drain to Source Volt.	V	7.5	8.0
Tch	Channel Temperature	°C	+150	+175
Tst	Storage Temperature	°C	-65 to+160	+180
Pin	RF Input Power	mW	240	360
Pt	Total Power Dissipation	mW	2700	3300

Notes:

1. Exceeding any one of these limits in continuous operation may reduce the mean-time- to-failure below the design goal.
2. Exceeding any one of these limits may cause permanent damage.

ORDERING INFORMATION:

When placing order or inquiring, please specify BIN range, wafer number, if known, and visual screening level required. For details of BIN Selection and Safe Handling Procedure please see supplementary information in available PDF on our website www.mwtinc.com.