

## Features:

- 11.5 dB Small Signal Gain at 12 GHz
- 20.5 dBm Output Power at 12 GHz
- 0.3 x 180 Micron Refractory Metal/Gold Gate
- Excellent for Medium Power Applications up to 28 GHz
- Ideal for Commercial, Military, Hi-Rel Space Applications

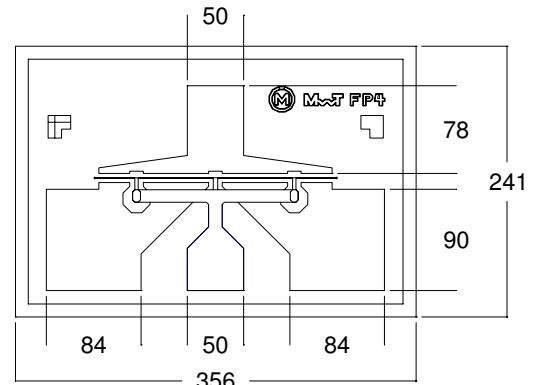

**Chip Dimensions: 356 x 241 microns**  
**Chip Thickness: 125 microns**

## Description:

The MwT-PH4 is a AlGaAs/InGaAs PHEMT (Pseudomorphic-High-Electron-Mobility-Transistor) device whose nominal 0.3 micron gate length and 180 micron gate width make it ideally suited for applications requiring power up to 28 GHz frequency range. The device is equally effective for either wideband (e.g. 6 to 18 GHz) or narrow-band applications. The chip is produced using MwT's reliable metal systems and all devices from each wafer are screened to insure reliability. All chips are passivated using MwT's patented "Diamond-Like Carbon" process for increased durability.

## Electrical Specifications:

• at  $T_a = 25\text{ }^\circ\text{C}$

SYMBOL	PARAMETERS & CONDITIONS	FREQ	UNITS	MIN	TYP
P1dB	Output Power at 1dB Compression Vds=7.0 V Ids=0.6xIDSS=48 mA	12 GHz	dBm	20	20.5
SSG	Small Signal Gain VDS=6.0 V Ids=0.6 x IDSS=48 mA	12 GHz	dB	10	11.5
PAE	Power Added Efficiency at P1dB VDS=7.0 V Ids=0.6xIDSS=50 mA	12 GHz	%		50
NFopt	Optimum Noise Figure Vds=2.8 V Ids=11 mA	12 GHz	dB		2.5
GA	Gain at Optimum Noise Figure Vds=3.0 V Ids=20 mA	12 GHz	dB		7
IDSS	Recommended IDSS Range for Optimum P1dB		mA		25- 66



# MwT-PH4

## 28 GHz Medium Power AlGaAs/InGaAs PHEMT Preliminary Data Sheet

June 2011

### DC Specifications: • at $T_a = 25\text{ }^\circ\text{C}$

SYMBOL	PARAMETERS & CONDITIONS	UNITS	MIN	TYP	MAX
IDSS	Saturated Drain Current $V_{ds}=3.0\text{ V}$ $V_{gs}=0.0\text{ V}$	mA	25		66
Gm	Transconductance $V_{ds}=2.5\text{ V}$ $V_{gs}=0.0\text{ V}$	mS	35	50	
Vp	Pinch-off Voltage $V_{ds}=3.0\text{ V}$ $V_{gs2}=0\text{ V}$ $I_{ds}=0\text{ mA}$	V		-1.2	-2.5
BVGSO	Gate-to-Source Breakdown Voltage $I_{gs} = -0.4\text{ mA}$	V	-5	-8	
BVGDO	Gate-to-Drain Breakdown Voltage $I_{gd} = -0.4\text{ mA}$	V	-10.0	-14	
Rth	Chip Thermal Resistance	$^\circ\text{C/W}$		200*	

\* Overall Rth depends on case mounting

### MAXIMUM RATINGS AT $T_a = 25\text{ }^\circ\text{C}$

Symbol	Parameter	Units	Cont Max1	Absolute Max2
VDS	Drain to Source Voltage	V	6.5	7.0
Tch	Channel Temperature	$^\circ\text{C}$	+150	+175
Tst	Storage Temperature	$^\circ\text{C}$	-65 to +150	+175
Pin	RF Input Power	mW	65	100
Pt	Total Power Dissipation	mW	575	720

#### Notes:

1. Exceeding any one of these limits in continuous operation may reduce the mean-time- to-failure below the design goal.
2. Exceeding any one of these limits may cause permanent damage.

#### ORDERING INFORMATION:

When placing order or inquiring, please specify BIN range, wafer number, if known, and visual screening level required. For details of BIN Selection and Safe Handling Procedure please see supplementary information in available PDF on our website [www.mwtinc.com](http://www.mwtinc.com).