

Features

- Ideal for DC-4000 MHz High Power / High Linearity Applications
- Excellent RF Performance:
 - 33 dBm P1dB
 - 47 dBm IP3
 - 16 dB SSG @ 2000 MHz
 - 40% PAE
- MTTF > 100 years @ Channel Temperature 150°C
- QFN 4x4 mm Surface Mount Package

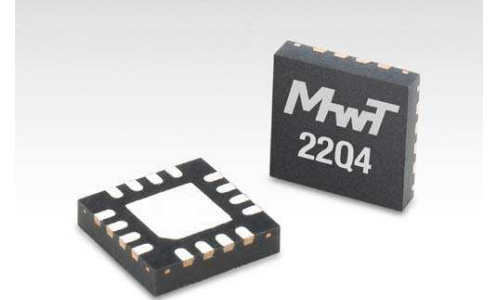

Description

The MwT-22Q4 is a high linearity GaAs MESFET device in low cost QFN package that is ideally suited for high power / high linearity applications. The applications include 2G, 2.5G, and 3G wireless infrastructure standards, such as GSM, TDMA, cdma, Edge, cdma2000, WCDMA, TD-SCDMA, and UMTS base stations. This product is also ideal for high data rate wireless LAN infrastructure applications, such as high QAM rate 802.11 WiFi and 802.16 WiMax base stations and APs (Access Points). In addition, the product can be used for point-to-point microwave communications links. The third order intercept performance of the MwT-22Q4 is excellent, typically 14 dB above the 1 dB power gain compression point. The chip is produced using MwT's proprietary high linearity device design and process with reliable metal system. All chips are passivated using MwT's patented "Diamond-Like Carbon" process for increased durability.

RF Specifications ⁽¹⁾

• $V_{ds} = 7.5V$, $I_{ds} = 560mA$, $T_a = 25^\circ C$ (1)

SYMBOL	PARAMETERS & CONDITIONS	FREQ	UNITS	MIN	TYP
SSG	Small Signal Gain	4 GHz	dB	12.0	13.5
P1dB	Output Power at 1dB Compression	4 GHz	dBm	32.0	33.0
OIP3	Output IP3	4 GHz	dBm		47
PAE	Power Added Efficiency at P1dB	4 GHz	%		40

(1) RF measurement is taken in a test fixture with tuners at input and output.

DC Specifications (Ta = 25°C)

SYMBOL	PARAMETERS & CONDITIONS	UNITS	MIN	TYP	MAX
IDSS	Saturated Drain Current Vds= 4.0 V Vgs= 0.0 V	mA	800		1200
Gm	Transconductance Vds= 2.5 V Vgs= 0.0 V	mS	500	650	
Vp	Pinch-off Voltage Vds= 3.0 V Ids= 30 mA	V		-1.2	-5.0
BVGSO	Gate-to-Source Breakdown Voltage Igs= -5.0 mA	V	-8.0	-12.0	
BVGDO	Gate-to-Drain Breakdown Voltage Igd= -5.0 mA	V	-12.0	-14.0	
Rth	Thermal Resistance	°C/W		16	

Outline Diagram

MwT-22Q4 OUTLINE

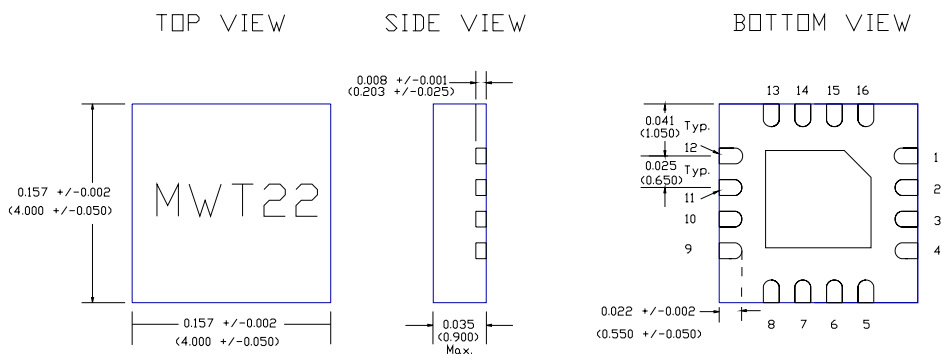

Notes:

- Unit : inches/(mm)
- Gate : 2 & 3 (both required)
- Drain : 10 & 11 (both required)
- Source : Backside ground
- Ground Pad : 0.087" X 0.087" Typ.



MwT-22Q4

High Power, High Linearity Packaged FET

Absolute Maximum Rating (Ta= 25 °C)*

SYMBOL	PARAMETERS	UNITS	ABSOLUTE MAXIMUM
Vds	Drain-Source Voltage	V	9
Vgs	Gate-Source Voltage	V	-6 to +0.8
Ids	Drain Current	mA	800
Igs	Gate Current	mA	5
Pdiss	DC Power Dissipation	W	6
Pin max	RF Input Power	dBm	+28
Tch	Channel Temperature	°C	150
Tstg	Storage Temperature	°C	-65 to 150

*Operation of this device above any one of these parameters may cause permanent damage.

Application Circuits

Typical RF Performance(2) Vds=7.5V, Ids=560mA, Ta=25°C

Parameter	Units	Typical Data			
		870-960	2110-2170	2400-2600	3400-3600
Test Frequency	MHz	870-960	2110-2170	2400-2600	3400-3600
Gain	dB	19	16	15	12
Input Return Loss	dB	-12	-11	-10	-10
Output Return Loss	dB	-5	-6	-7	-6
P1dB	dB	33	33	33	32
Output IP3	dBm	44	46	46	45
Noise Figure	dB	2.7	2.9	3.0	3.8

2. See Circuit Schematic for details of matching circuits.

Typical Scattering Parameters: (Vds= 7.5V, Ids= 550mA, Ta = 25°C Reference Planes at Leads)

F[GHz]	S11		S21		S12		S22	
	Mag	Ang	Mag	Ang	Mag	Ang	Mag	Ang
0.05	0.95	-33.45	24.11	159.65	0.01	88.41	0.26	-142.44
0.25	0.90	-111.86	13.93	119.43	0.03	31.22	0.52	-160.02
0.50	0.89	-148.14	8.01	98.31	0.03	13.59	0.59	-173.10
0.75	0.90	-164.10	5.40	87.21	0.03	5.76	0.61	-179.47
1.00	0.90	-172.81	3.99	79.61	0.03	2.05	0.63	177.27
1.25	0.90	-177.72	3.13	74.14	0.03	-0.10	0.64	175.73
1.50	0.90	179.59	2.57	69.75	0.03	-0.62	0.64	175.44
1.75	0.90	178.38	2.19	65.99	0.03	-1.56	0.64	175.81
2.00	0.90	177.97	1.92	62.77	0.03	-0.40	0.63	176.46
2.25	0.89	177.88	1.73	59.55	0.03	-0.54	0.62	176.79
2.50	0.89	177.68	1.61	56.19	0.03	-0.60	0.61	176.32
2.75	0.88	176.90	1.52	52.44	0.03	-1.50	0.59	174.61
3.00	0.87	174.99	1.45	47.68	0.03	-3.49	0.57	171.05
3.25	0.86	171.54	1.41	41.91	0.04	-6.70	0.55	165.56
3.50	0.86	166.47	1.36	34.85	0.04	-10.26	0.54	158.14
3.75	0.85	159.69	1.28	26.94	0.04	-15.03	0.54	149.75
4.00	0.85	152.31	1.19	18.82	0.04	-19.42	0.56	141.79

Circuit Schematic:

The information and the circuit provided in this note intend to show the capability of MWT22Q4 and to help customers use the device in their designs. It is a reference only.

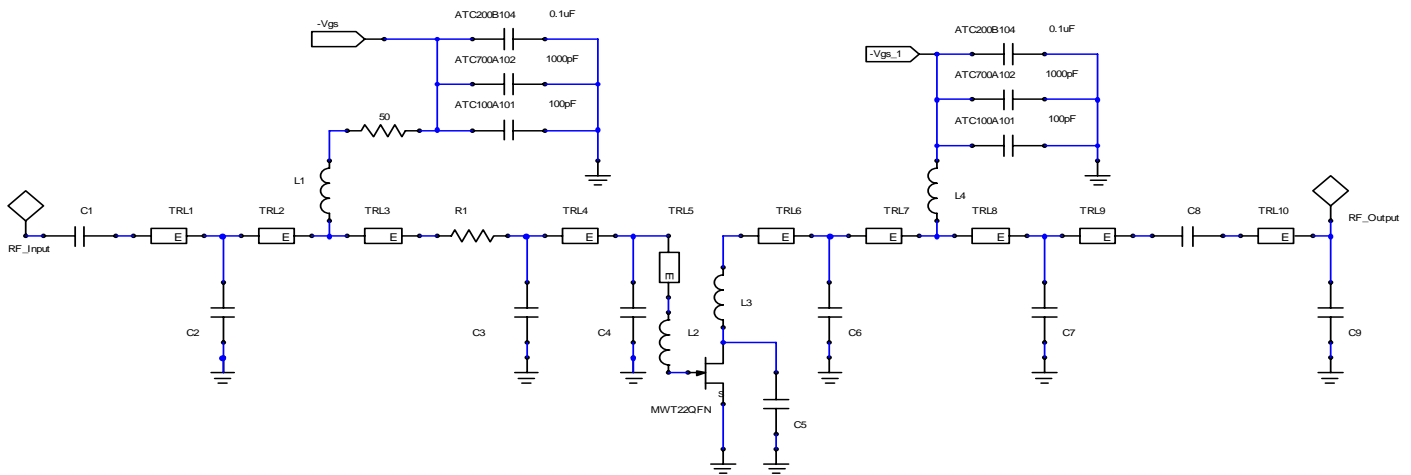

Bill of Materials:

Reference Designator	Value				Unit	part	Size
	0.87 – 0.96	2.1 – 2.2	2.4 – 2.6	3.4 – 3.6	GHz		
C1	22	8.2	4.7	5.6	pF	Chip capacitor	0505
C2	6	2.2	0	0	pF	Chip capacitor	0505
C3	0	6.0	1.1	0.4	pF	Chip capacitor	0505
C4	0	0	3.9	3.3	pF	Chip capacitor	0505
C5	1.8	3.9	0.4	2.0	pF	Chip capacitor	0505
C6	0	2.0	1.8	1.0	pF	Chip capacitor	0505
C7	2.0	1.2	0	0	pF	Chip capacitor	0505
C8	100	8.2	33	5.6	pF	Chip Capacitor	0505
C9	3.0	0	0	0	pF	Chip capacitor	0505
R1	2.7	0	0	0	Ohm	Chip resistor	0603
L1	100	47	47	43	nH	Chip Inductor	0603
L2	1.8	0	0	0	nH	Chip Inductor	0603
L3	1.15	0	0	0	nH	Chip Inductor	0603
L4	51	47	47	43	nH	Chip Inductor	0603
TRL1	0	9.5	41	50	Deg.	50 Ohm TRL	
TRL2	7.5	14	0	0	Deg.	50 Ohm TRL	
TRL3	6	12	7	10	Deg.	50 Ohm TRL	
TRL4	0	9.5	14	29	Deg.	50 Ohm TRL	
TRL5	0	0	7	0	Deg.	50 Ohm TRL	
TRL6	5	16.5	21	29	Deg.	50 Ohm TRL	
TRL7	0	7	7	15	Deg.	50 Ohm TRL	
TRL8	3	7	34	48	Deg.	50 Ohm TRL	
TRL9	5	16.5	0	0	Deg.	50 Ohm TRL	
TRL10	6	0	0	0	Deg.	50 Ohm TRL	