



MwT-0206L-VRM/0206U-VRM

2.0-6.0 GHz Voltage Regulator Module

www.mwtinc.com

Email: info@mwtinc.com

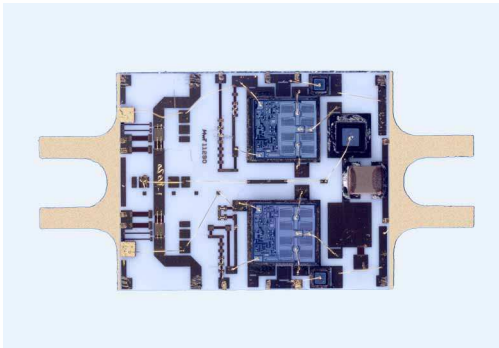

TYPICAL SPECIFICATIONS AT 25 °C

- DUAL ADJUSTABLE VOLTAGE REGULATOR
- INTEGRAL 50 OHM LINE FOR RF INTERCONNECTION
- CURRENT CAPABILITY: UP TO 400mA PER CHIP
800mA MAX PER MODULE
- BUILT-IN REVERSE VOLTAGE PROTECTION
- BUILT-IN THERMAL SHUTDOWN

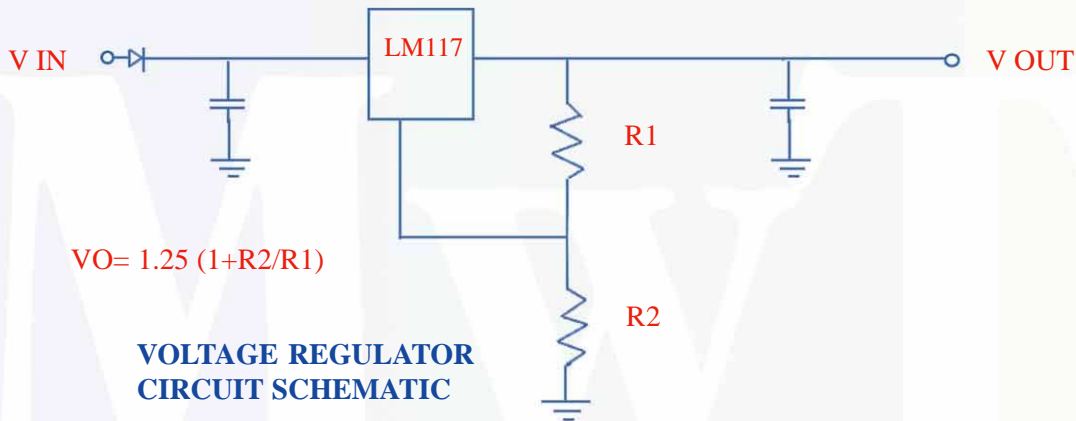

ELECTRICAL SPECIFICATIONS (Ta=25°C)

SYMBOL	PARAMETERS	UNITS	MIN	TYP	MAX
FREQ	Frequency Range	GHz	0.5		6.0
VIN	Power Supply Voltage	+V	10.7	12.0	20.0
V OUT1	Regulated Output Voltage 1 (1)	+V	7.9	8.0	8.1
V OUT2	Regulated Output Voltage 2 (2)	+V	7.9	8.0	8.1
IDC	DC Current, total for two regulators	mA			800
IR	Residual Current	mA			20.0
RR	Ripple Rejection @ 120 Hz	dB	50.0		
Pd	Max. DC power dissipation @ each regulator	Watts	1.5		

(1) The output voltage can be adjusted between 1.25 volts to Vin - 2.7 volts



MWT-0206L-VRM/0206U-VRM

2.0-6.0 GHz Voltage Regulator Module

www.mwtinc.com

Email: info@mwtinc.com

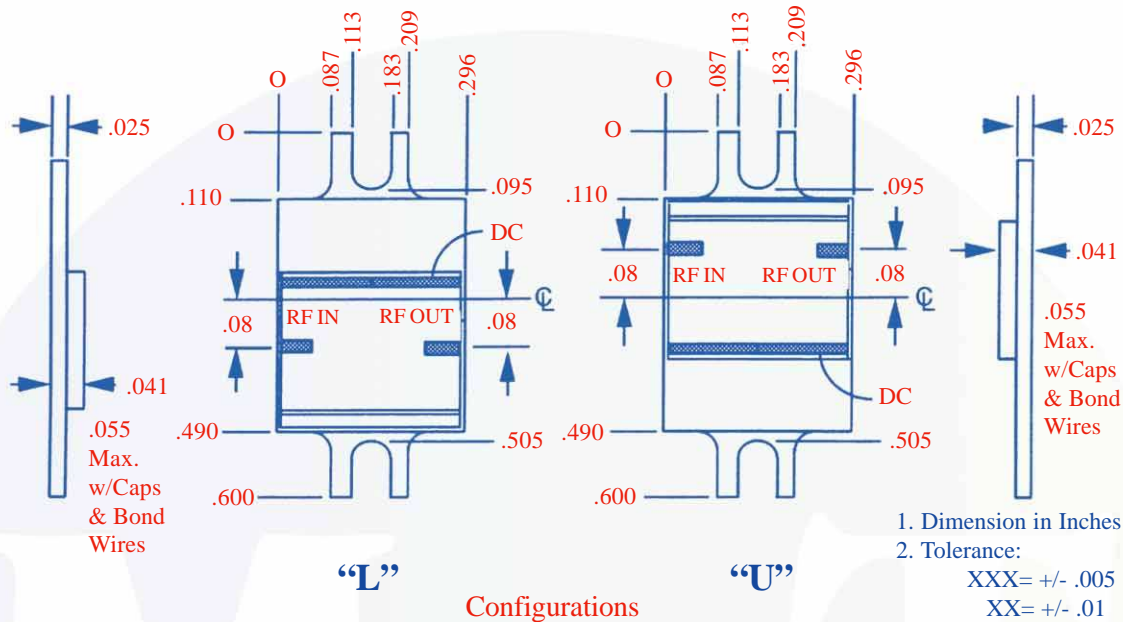

Construction:

The 15 mil alumina substrate is brazed onto the 25 mil carrier using AuGe preform. The voltage regulators are attached utectically to the substrates. All other components are attached using AuSn preforms. The flanges are designed to accommodate 0-80 UNF-2A socket or Fillister head screws on .500 center-to-center hole spacing. The modules are mechanically and electrically designed to be cascaded.

Notes:

1. Custom module specifications and/or custom module mechanical configurations are available.
2. Operating Temperature Range is -55 degrees Celsius to +105 degrees Celsius.
3. All modules are serialized and shipped with data measured at 25 degrees Celsius. Data includes swept small signal gain, swept input and output return loss. Noise figure and P-1dB are measured in 1 GHz increments. Special module testing is available.
4. Test Fixtures are available.
5. Microwave Technology reserves the right to ship modules with performance above the typical specifications.

4268 Solar Way • Fremont • California 94538 • Phone: (510) 651-6700 • Fax: (510) 651-2208

All rights reserved. MicroWave Technology, Inc. All specifications subject to change without notice.