



# MWT-0206S-TCM/0206Z-TCM

2.0-6.0 GHz Balanced Temp. Comp. Module

www.mwtinc.com

Email: info@mwtinc.com

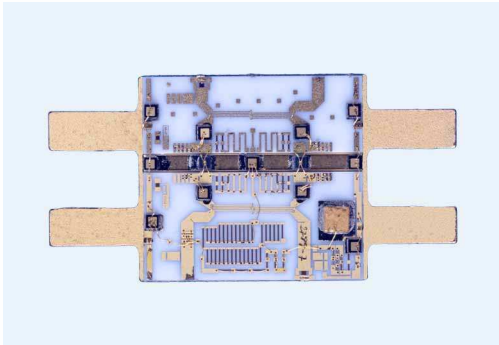

## TYPICAL SPECIFICATIONS AT 25 °C

- FLAT FREQUENCY RESPONSE
- LOW INSERTION LOSS AT ZERO BIAS
- BUILT-IN THERMISTOR FOR TEMPERATURE COMPENSATION
- HIGH DYNAMIC RANGE
- FLEXIBLE ADJUSTMENT TO SUIT DIFFERENT TEMPERATURE COMPENSATION REQUIREMENTS

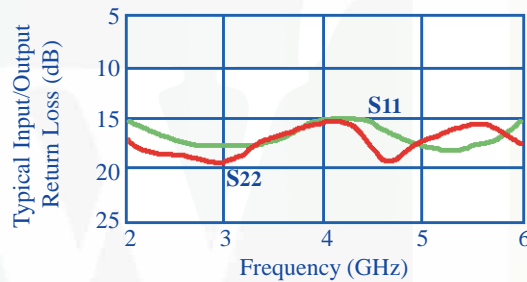
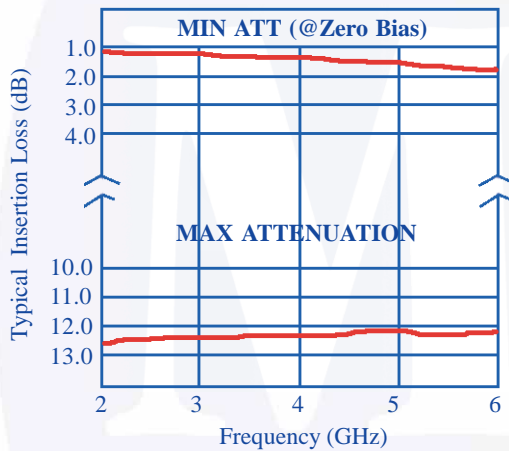

## ELECTRICAL SPECIFICATIONS

(Ta=25°C)

SYMBOL	PARAMETERS	UNITS	MIN	TYP	MAX
FREQ	Frequency Range	GHz	2.0		6.0
IL	Insertion Loss @ min Attenuation (No Bias)	dB		1.5	2.5
ATTEN.	Insertion Loss @ max Attenuation	dB	12.0	13.0	
$\Delta IL/\Delta F$	Insertion Flatness over Freq @ any Atten.	+/-dB		0.4	0.6
VSWR IN	Input VSWR	----		1.6:1	1.8:1
VSWR OUT	Output VSWR	----		1.6:1	1.8:1
VDC	Power Supply Voltage	+V	6.0	8.0	9.0
IDC	DC Current	mA		10.0	20.0

4268 Solar Way • Fremont • California 94538 • Phone: (510) 651-6700 • Fax: (510) 651-2208

All rights reserved. MicroWave Technology, Inc. All specifications subject to change without notice.

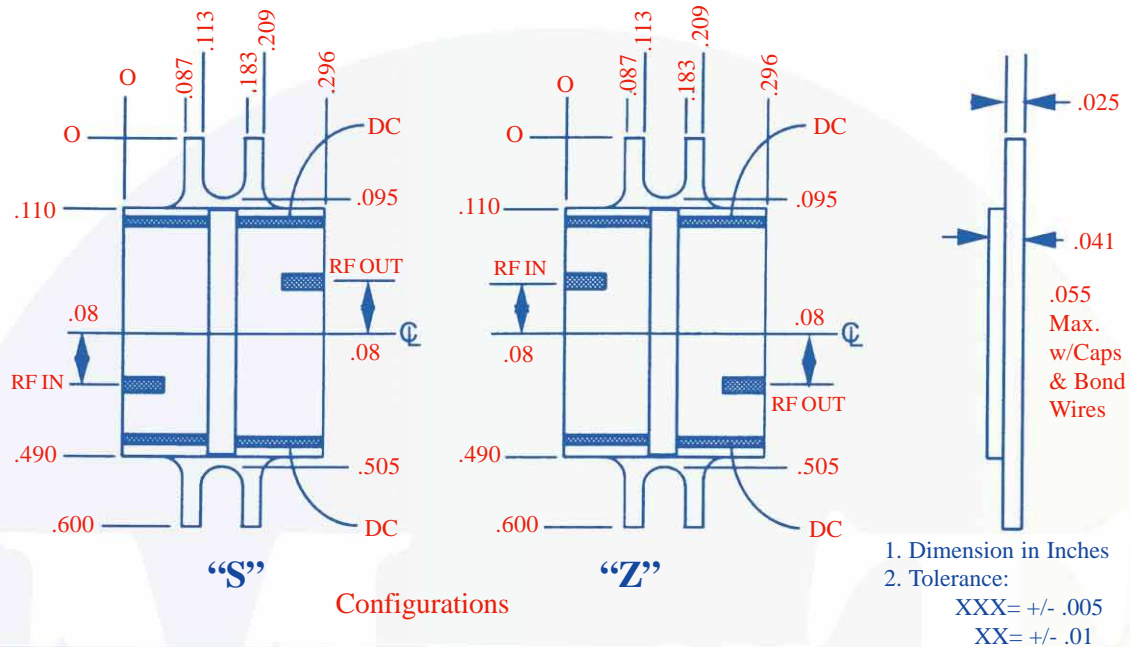

## Construction:

The 15 mil alumina substrates and 10 mil copper FET ridge are brazed onto the 25 mil carrier using AuGe preform. The PIN diodes are attached to the Cu ridge using AuSn preform. All capacitors are attached using AuSn preforms. The flanges are designed to accommodate 0-80 UNF-2A socket or Fillister head screws on .400 center-to-center hole spacing. The modules are mechanically and electrically designed to be cascaded.

## Notes:

1. Custom module specifications and/or custom module mechanical configurations are available.
2. Operating Temperature Range is -55 degrees Celsius to +105 degrees Celsius.
3. All modules are serialized and shipped with data measured at 25 degrees Celsius. Data includes swept small signal gain, swept input and output return loss. Noise figure and P-1dB are measured in 1 GHz increments. Special module testing is available.
4. Test Fixtures are available.
5. Microwave Technology reserves the right to ship modules with performance above the typical specifications.