

Features:

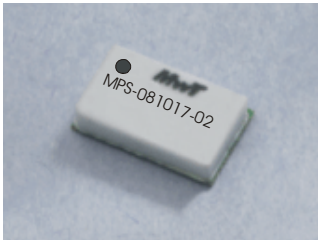

- +45 dBm IP3**
- 15 dB Gain**
- 2.0:1 VSWR**
- +28.5 dBm P1dB**
- Single Positive Bias**
- Leadless Surface Mount Package (02)**

The MPS-081017-02 is a low cost high linearity modular amplifier designed to meet the ultra-linear transmitter driver requirements for commercial 2G, 2.5G, 3G, GSM, TDMA, EDGE, UMTS, WCDMA, CDMA2000, and TD-SCDMA applications. Key advantages are low intermodulation performance for multi-carrier and CDMA systems and low input/output return loss for ease of integration.

Electrical Specifications @ 25°C, V_{dd} = 7.5 V, Z_o = 50 ohms

SYMBOL	PARAMETERS	Min	Typical	Max	Unit
Freq.	Frequency Range	800		1000	MHz
SSG	Small Signal Gain	14.0	15.0		dB
P1 dB	Pout at 1 dB Comp Point		+28.5		dBm
IP3 (1)	Third-Order Intercept	42	45		dBm
VSWR	VSWR (Input/Output)		2.0:1/2.5:1		
GOF	Gain Var. over Frequency		± 0.25	± 0.5	dB
GOT	Gain Var. over Temp		-0.015		dB/°C
I_{dd}	DC Current		380	450	mA

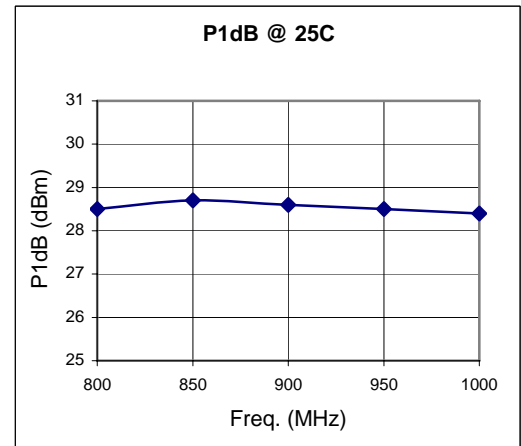

(1) Two tone test @ 13 dBm/tone, centered at 900 MHz with separation of 20 MHz.

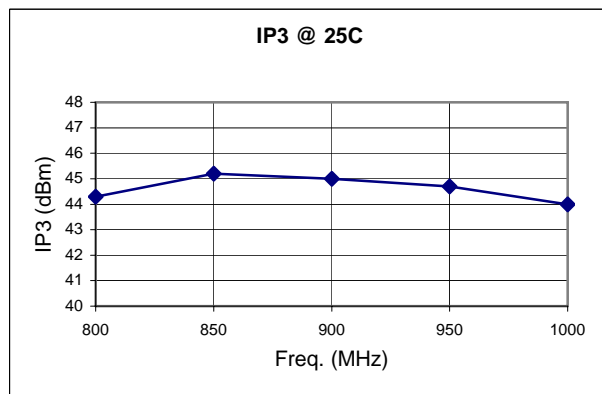

Absolute Maximum Ratings

Maximum Bias Voltage	8.0 V
Maximum Continuous RF Input Power	950 mW
Maximum Peak Input Power	1400 mW
Maximum Case Operating Temperature	+85 °C
Maximum Storage Temperature	- 65 to + 150 °C

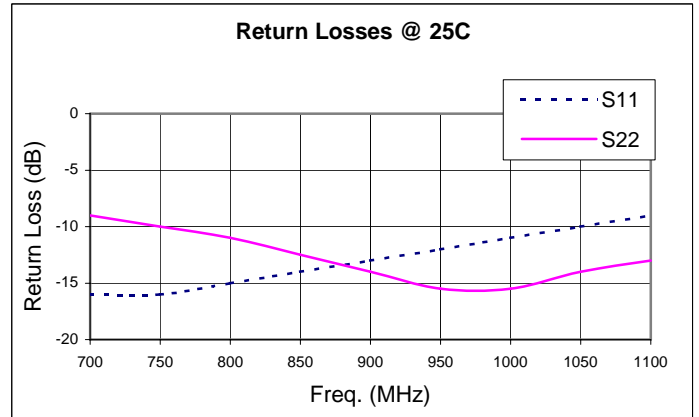
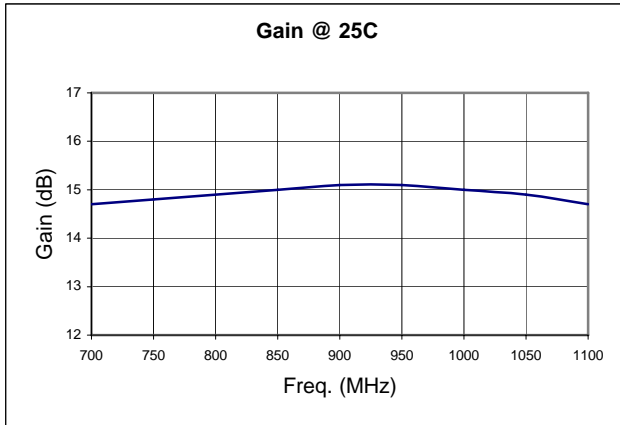

Outline Diagram (Package 02)

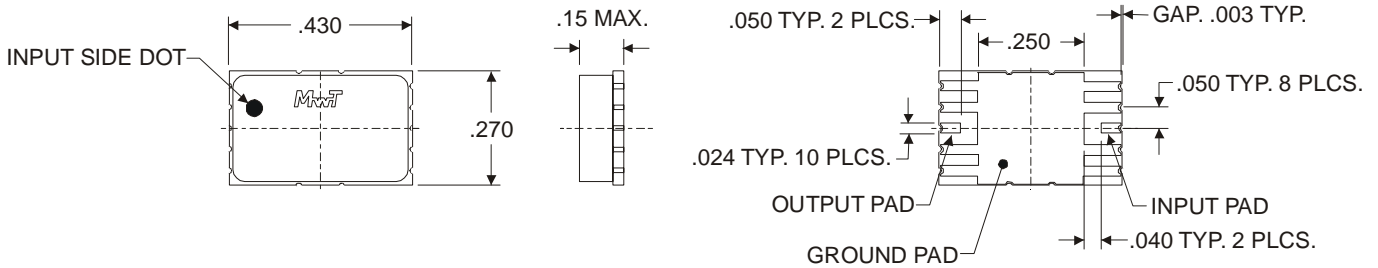

Application Circuit

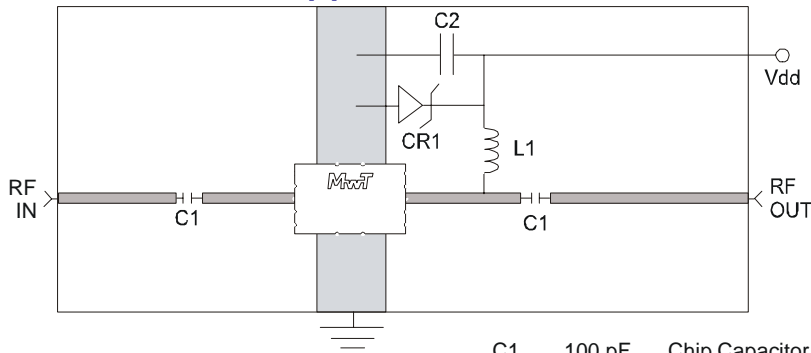

- | | | |
|-----|--------|-----------------------|
| C1 | 100 pF | Chip Capacitor |
| C2 | 22 uF | Capacitor |
| L1 | 160 nH | Printed or Wound Coil |
| CR1 | 8.0 V | Zener Diode |

— 50 ohm Microstrip Line