

FEATURES

- **Wideband:** 1.0 to 12 GHz
- **NF:** 1.3 dB @ 2.0 GHz
1.4 dB @ 6.0 GHz
1.9 dB @ 12.0 GHz
- **P-1dB:** 16 dBm @ 6.0 GHz
- **OIP3:** 27 dBm @ 6.0 GHz
- **Gain:** 17 dB @ 6.0 GHz
- **Bias Condition:** VDD = 5 V
IDD = 55 mA
- **50-Ohm On-chip Matching**
- **Unconditionally Stable: 50 MHz to 20 GHz**
- **Gain Control Option Available with 2nd Gate Control Voltage**
- **4x4 mm, 24 Lead Ceramic SMT Package**

APPLICATIONS

- **Microwave Point-to-Point Radios**
- **Satellite and Telemetry Communications**
- **Test Instrumentation**
- **EW Receiver Systems**
- **Wide-band Communication Systems**
- **Commercial Wireless Systems**

DESCRIPTION

The MLA-01122B-C4 is a packaged fully-matched broadband Low-Noise MMIC amplifier utilizing high-reliability low-noise GaAs PHEMT technology. This MMIC is suited for Satellite Communications, Microwave radios, Instrumentation, Wideband Systems and also many commercial wireless applications where low-noise figure with high-gain is desirable. It has excellent gain (17 dB) and Noise Figure (1.4 dB, mid-band) over a broad frequency range. Typical P-1dB is 16 dBm and OIP3 is +27dBm @ 6 GHz. It has on-chip bias circuit, choke and DC blocking to provide bias stability and ease of use. The 2nd Gate voltage input can be used for gain control if necessary. Available in 4x4mm, 24 Lead Ceramic SMT Package.

ELECTRICAL SPECIFICATIONS: VDD=+5.0V, VG1=+0.13V, VG2=+2V, IDD=55 mA, Ta=25 C, ZO=50 ohm ⁽¹⁾

PARAMETER	TEST CONDITIONS	TYPICAL DATA	UNITS
Frequency Range		1-12	GHz
Gain	1 - 8 GHz	17	dB
	10 - 12 GHz	19	
Gain Flatness	1 - 8 GHz	0.7	+/-dB
	1 - 12 GHz	1.5	
Input Return Loss	2 GHz	15	dB
	5 GHz	9.5	
	10 GHz	13	
Output Return Loss		11	dB
Output P1dB	2 GHz	17.5	dBm
	6 GHz	16.0	
	10 GHz	15.0	
	12 GHz	13.0	
Output IP3 @ 0 dBm/tone, 1 MHz separation	2 GHz	30	dBm
	6 GHz	27	
	12 GHz	25	
Noise Figure	2 GHz	1.3	dB
	6 GHz	1.4	
	12 GHz	1.9	
Operating Bias Conditions: VDD IDD	VG1=+0.13V, VG2=+2V	+5	V
		55	mA
Stability Factor K	0.05 to 20 GHz	> 1	

(1) All data is measured on Evaluation Board, with VG2 bias derived from VDD bias using resistive voltage divider as shown in Evaluation Board Schematic & Layout. (2) Vg1 can be slightly positive or negative depending on the lot and operation current.

TYPICAL RF PERFORMANCE: $V_{DD}=+5.0V$, $V_{G1}=+0.13V$, $V_{G2}=+2V$, $I_{DD}=55\text{ mA}$, $T_a=25\text{ C}$, $Z_0=50\text{ ohm}$ ⁽¹⁾

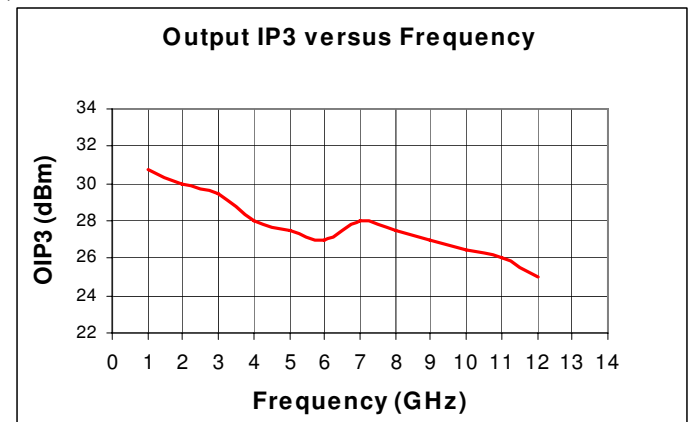
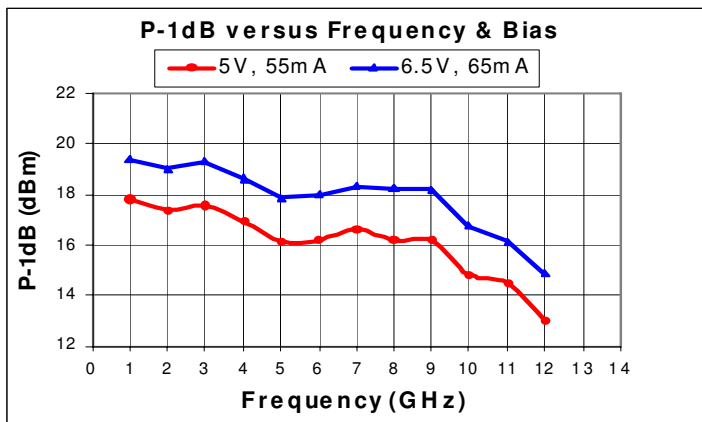
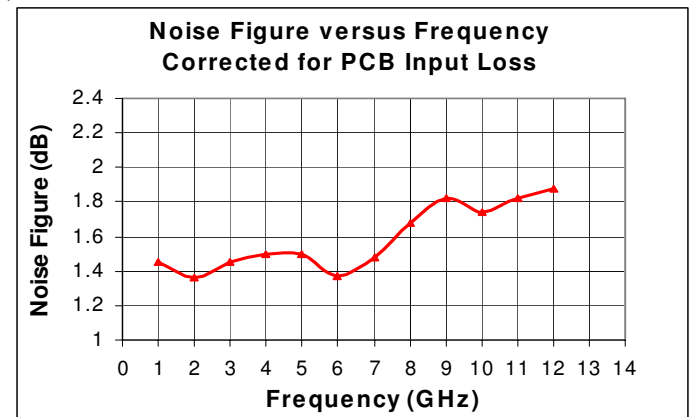
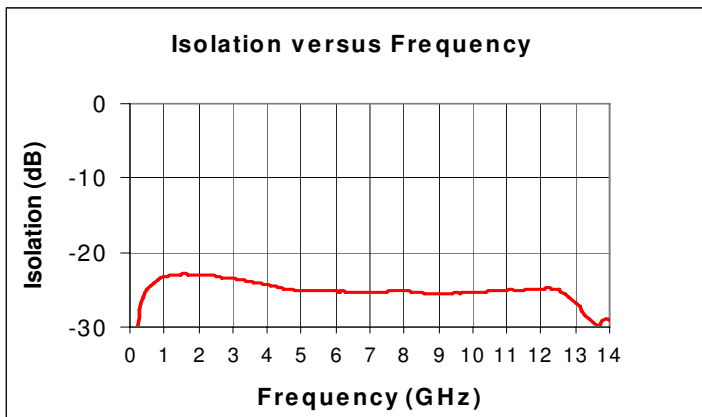
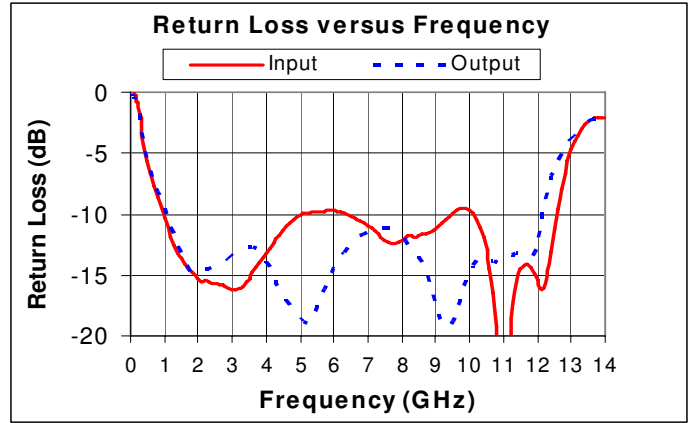
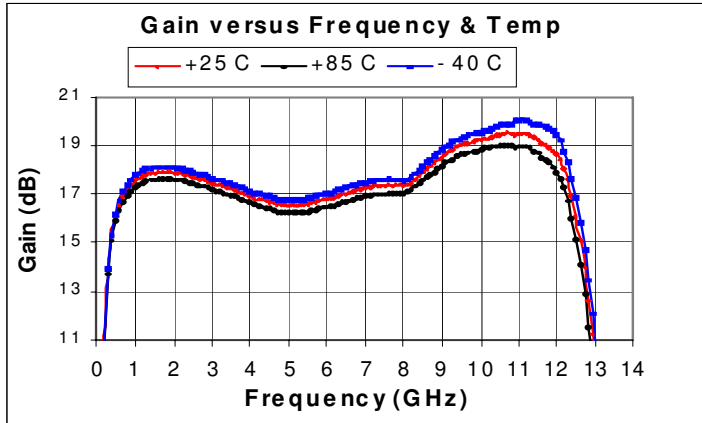

EVALUATION BOARD LAYOUT:

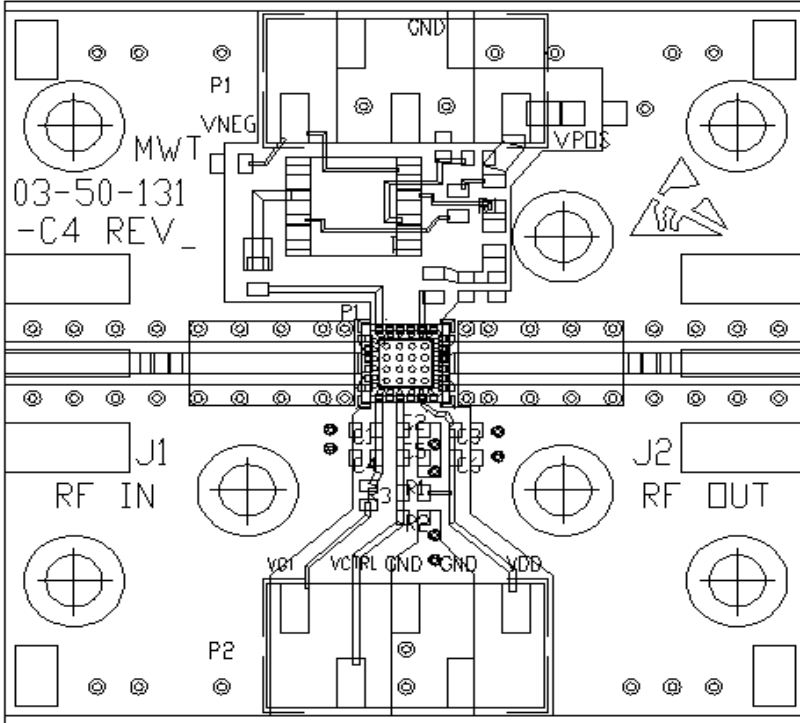

Parts List:

- C1,C2,C3: 04025C102KAT2A 1000pF AVX
- C4,C5,C6: 0402ZD104KA T2A 0.1uF AVX
- R1: RK73B1ETTP562J(0402)5.6k AVX
- R2: RK73B1ETTP392J(0402)3.9k AVX
- R3: RK73Z1ETTP(0402)0 Ohms AVX
- P2: TSM-105-01-S-SV SAMTEC
- J1,J2: 142-0701-841 JOHNSON
- PCB: 20 mil thick 2-Layer R04003
Vias are plated & filled with Cu
paste & planarized

NOTES:

- 1) BACKSIDE OF PACKAGE IS RF/DC GND AND MUST BE GROUNDED WITH ENOUGH VIAS AS SHOWN TO PCB RF/DC GND FOR BEST ELECTRICAL AND THERMAL PERFORMANCE

APPLICATION CIRCUIT SCHEMATIC:

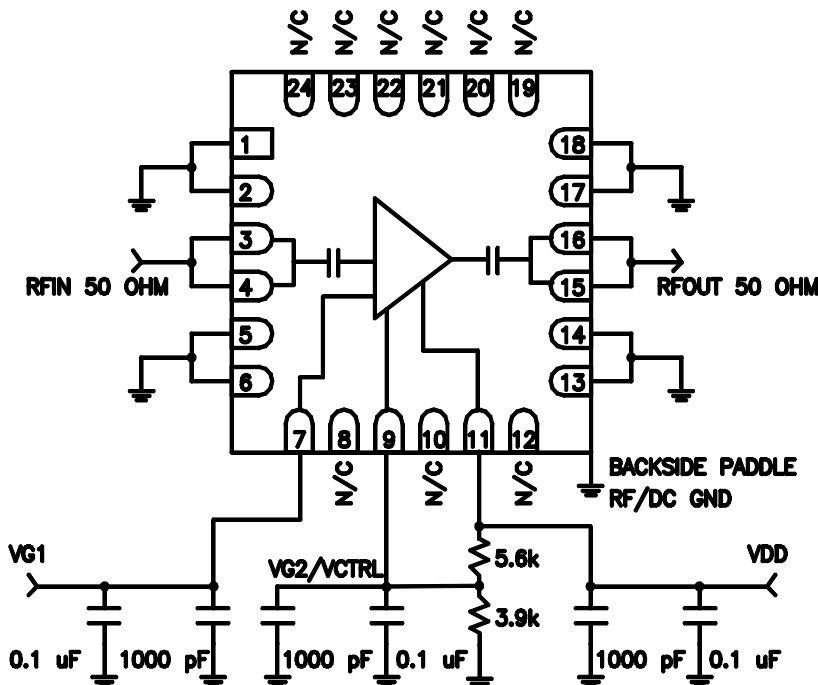

Notes:

- 1) Package Backside is RF/DC GND and must be well grounded through PCB vias.
- 2) External DC bypass capacitors must be placed as close to package as possible.

MECHANICAL INFORMATION

Outline Drawing

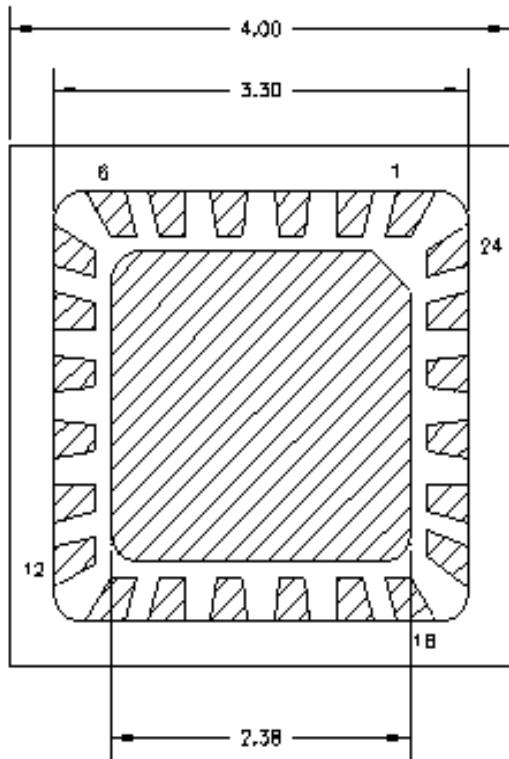

TOP VIEW

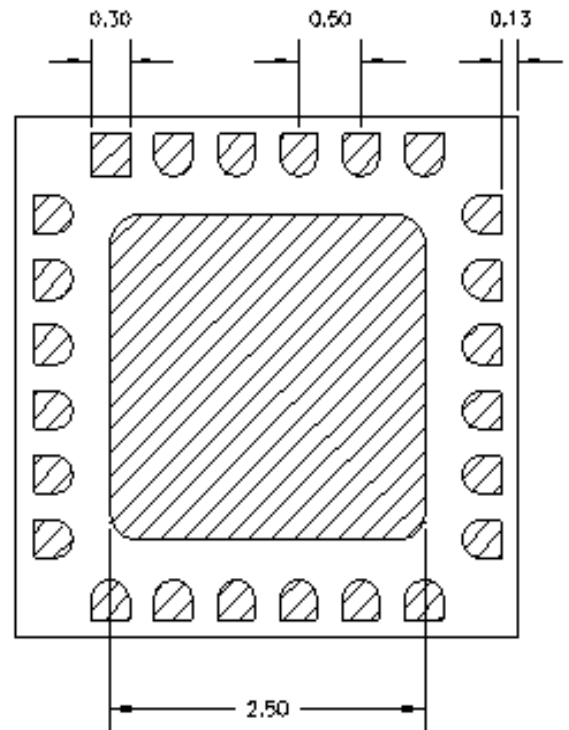
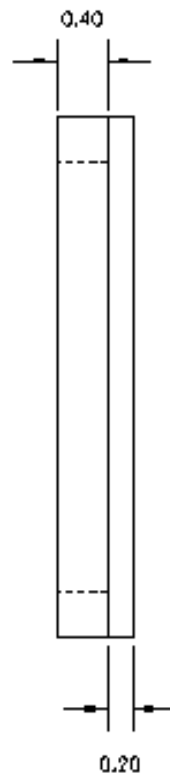

BOTTOM VIEW

Notes:

- 1) 4X4 mm, 24 Lead Ceramic Package Outline Drawing.
- 2) Dimensions are in millimeters.
- 3) Lead and Ground Paddle Plating: Gold
- 4) Package Material: Black Alumina
- 5) All GND Leads and Backside Paddle must be grounded to PCB RF/DC ground.

ABSOLUTE MAXIMUM RATINGS

SYMBOL	PARAMETERS	UNITS	MAX
VDD	Drain Voltage	V	7
IDD	Drain Current	mA	100
Pdiss	DC Power Dissipation	W	0.4
Pin max	RF Input Power	dBm	13
Toper	Operating Case/Lead Temp Range	°C	-40 to +85
Tch	Channel Temperature	°C	150
Tstg	Storage Temperature	°C	-60 to 150

Exceeding any on of these limits may cause permanent damage.

Functional Diagram

