

## Features:

- Frequency Range: 0.1 – 26.5 GHz
- P3dB: +27 dBm
- Gain: 12.5 dB
- Vdd =8 to 12 V
- Ids =250 to 500 mA
- Input and Output Fully Matched to 50 Ω

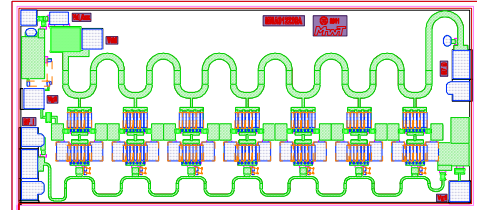

Die size: 2350 x 1050 x 50 um

## Applications:

- Fiber optics communication systems
- Microwave and wireless communication systems
- Microwave and optical instrumentations
- Military and EW equipments

## Description:

The MMA-012727 is a broadband GaAs MMIC Traveling Wave Amplifier (TWA) with medium output power and high gain over 0.1 to 26.5GHz frequency range. This amplifier is optimally designed for broadband applications requiring flat gain and high power with excellent input and output matches over a 0.1 to 26.5GHz frequency range.

## Absolute Maximum Ratings: *(Ta= 25 °C)\**

SYMBOL	PARAMETERS	UNITS	Min.	Max.
Vds	Drain-Source Voltage	V		12.5
Vg1	First Gate-Source Voltage	V	-2	0
Ig1	First Gate Current	mA	-10	1
Vg2	Second Gate-Source Voltage	V	-3.5	6
Ig2	Second Gate-Source Current	mA	-20	
Pdiss	Maximum Power dissipation	W		4.65
Pin max	RF Input Power	dBm		23
Tch	Channel Temperature	°C		+150
Tstg	Storage Temperature	°C		-55 to +165
Tmax	Max. Assembly Temp (60 sec max)	°C		+300

\*Operation of this device above any one of these parameters may cause permanent damage.

**Electrical Specifications:** *V<sub>ds</sub>=10V, V<sub>g1</sub>=-0.75V, V<sub>g2</sub>=1V, I<sub>ds</sub>=350mA, T<sub>a</sub>=25 °C Z<sub>0</sub>=50 ohm*

Parameter	Units	Min.	Typ.	Max.
Frequency Range	MHz	0.1		26,500
Gain (Typ / Min)	dB	11.5	12.5	
Gain Flatness (Typ / Max)	+/- dB		0.5	0.7
Input RL(Typ/ Max)	dB	9	11	
Output RL(Typ/ Max)	dB	9	11	
Output P1dB(Typ/ Min)	dBm	22	26	
Output IP3 <sup>(1)</sup>	dBm		35	
Output P3dB(Typ/ Min)	dBm	23	27	
Operating Current at P1dB (Typ/ Max)	mA		350	380
Thermal Resistance	°C / W		14	

(1) Output IP3 is measured with two tones at output power of 10 dBm/tone separated by 20 MHz.

## Typical RF Performance: $V_{ds}=10V$ , $V_{g1}=-0.75V$ , $V_{g2}=1V$ , $I_{ds}=350mA$ , $Z_0=50\text{ ohm}$ , $T_a=25\text{ }^\circ\text{C}$

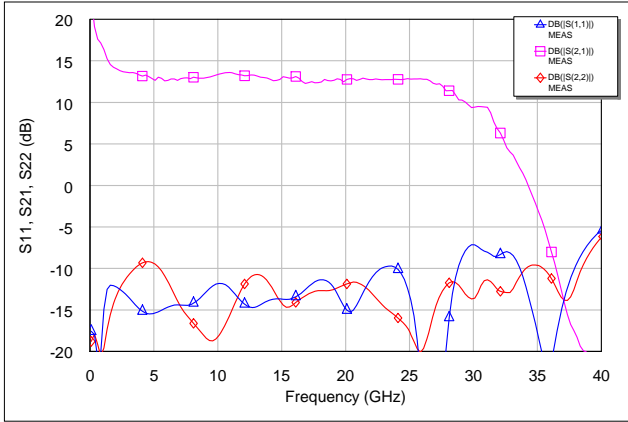

S11, S21, and S22 vs. Frequency

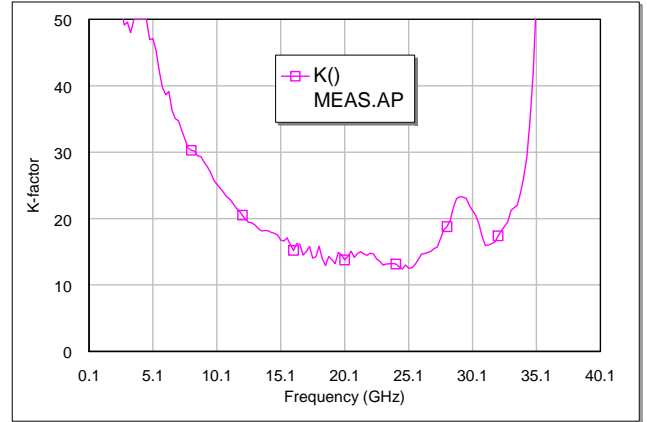

K-factor vs. Frequency

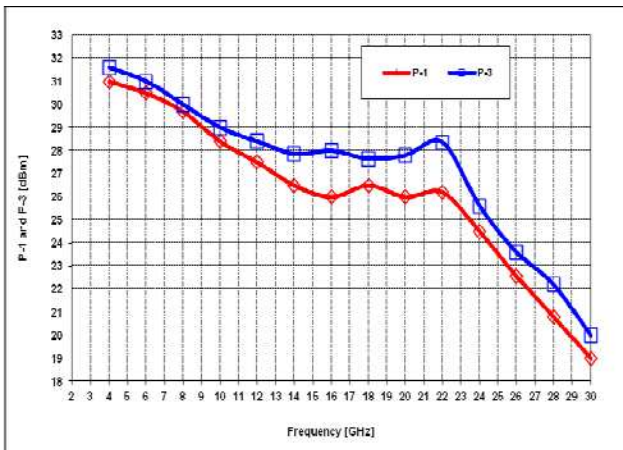

P-1 and P-3 vs. Frequency

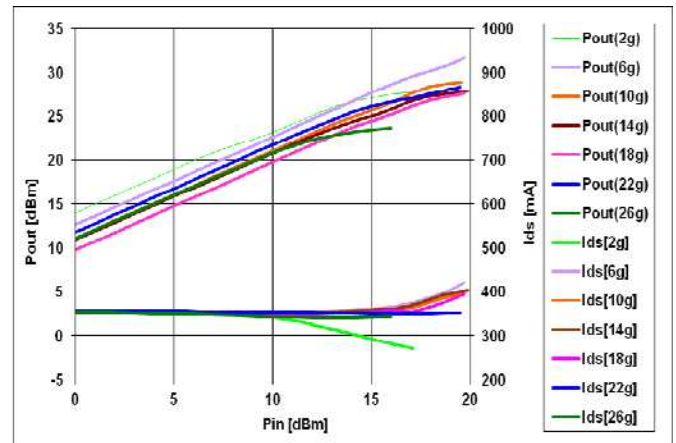

Pout and Ids vs. Pin

**Mechanical Information:** *Top view*

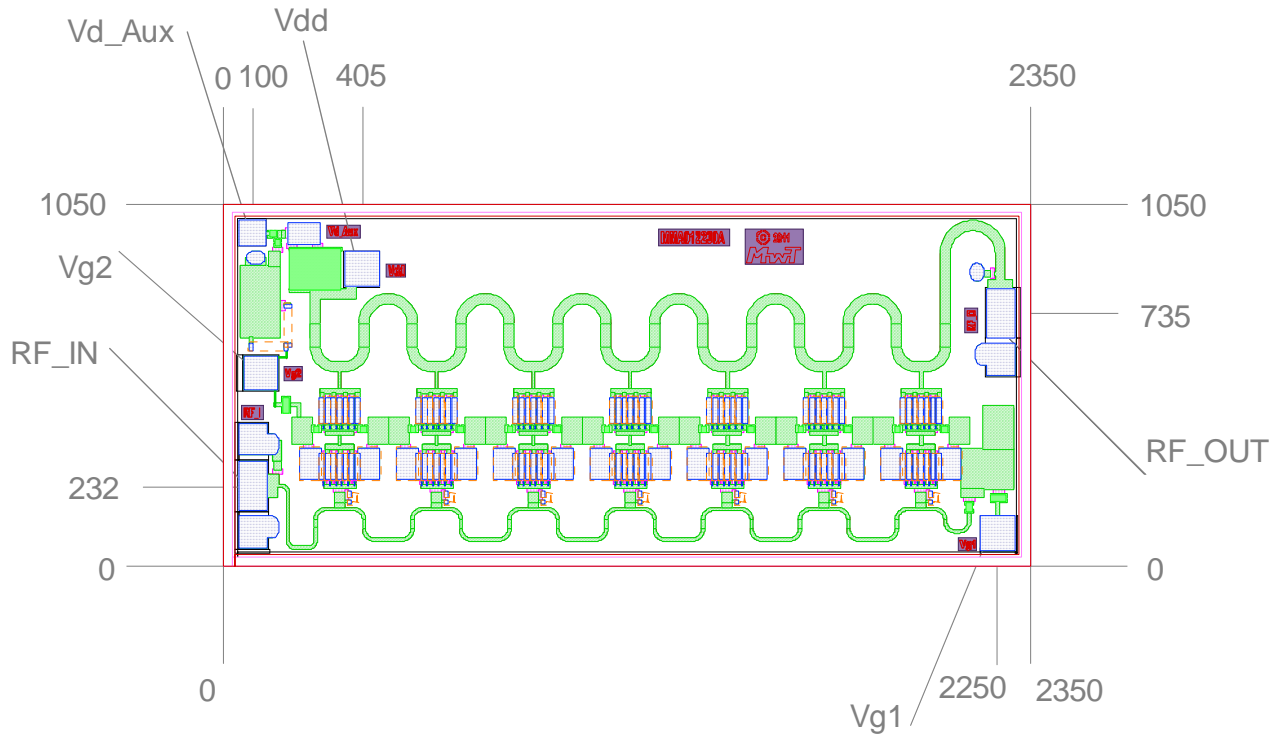

The units are in [um].

## Applications

The **MMA012727** traveling wave amplifier is designed for use as a general purpose wideband power stage in microwave communication systems, and test equipments. It is ideally suited for broadband applications requiring a flat gain response and excellent port matches over a 0.1 to 26.5 GHz frequency range. Dynamic gain control and low-frequency extension capabilities are designed into these devices.

## Biasing and Operation

The recommended bias conditions for best performance for the **MMA012727** are  $V_{DD} = 10V$ ,  $I_{DD} = 350mA$ . To achieve these drain current levels,  $V_{g1}$  is typically  $-0.75V$ , and  $V_{g2}$  is typically  $+1V$ . No other bias supplies or connections to the device are required for 0.1 to 26.5 GHz operation. The gate voltage ( $V_{g1}$ ) should be applied prior to the drain voltage ( $V_{d1}$ ) during power up and removed after the drain voltage during power down. Performance improvements are possible depending on applications. The drain bias voltage range is 8 to 12V and the quiescent drain current biasing range is 250mA to 500mA. The **MMA012727** is a DC coupled amplifier. External decoupling capacitors are needed on RFIN and RFOUT ports. The drain bias pad is connected to RF and must be decoupled to the lowest operating frequency. An auxiliary drain contacts is provided when performance below 2GHz is required. The second gate ( $V_{g2}$ ) can be used to obtain 30 dB (typical) dynamic gain control. For maximum gain operation, typical  $V_{g2}$  is  $+1V$ .

## Assembly Techniques

GaAs MMICs are ESD sensitive. ESD preventive measures must be employed in all aspects of storage, handling, and assembly. MMIC ESD precautions, handling considerations, die attach and bonding methods are critical factors in successful GaAs MMIC performance and reliability.

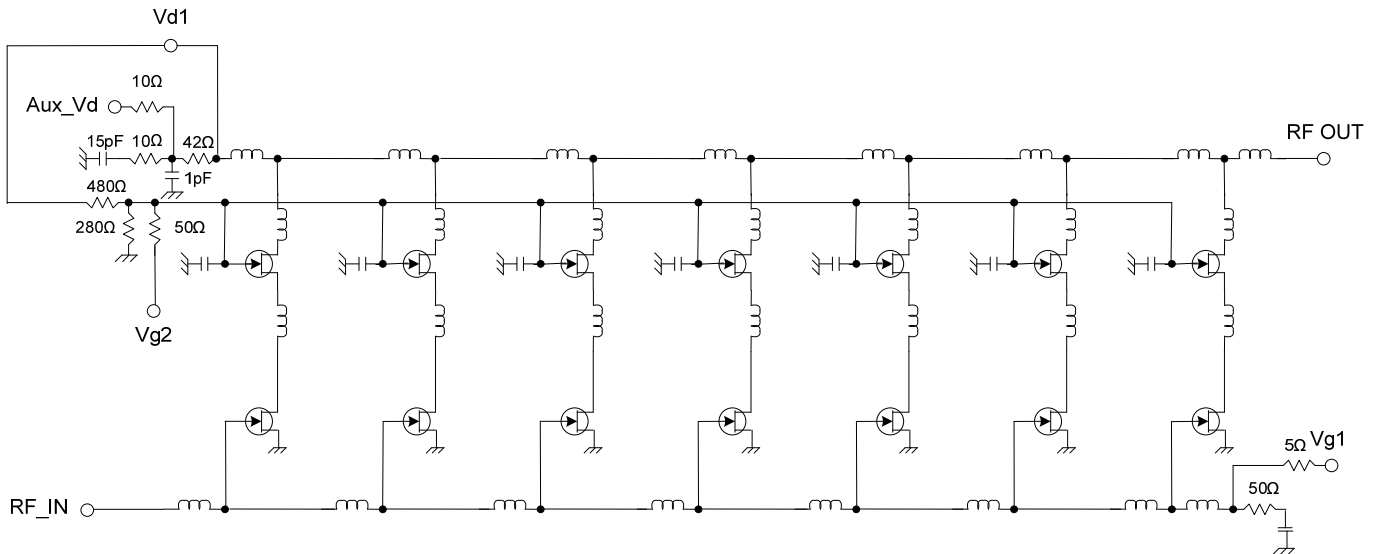

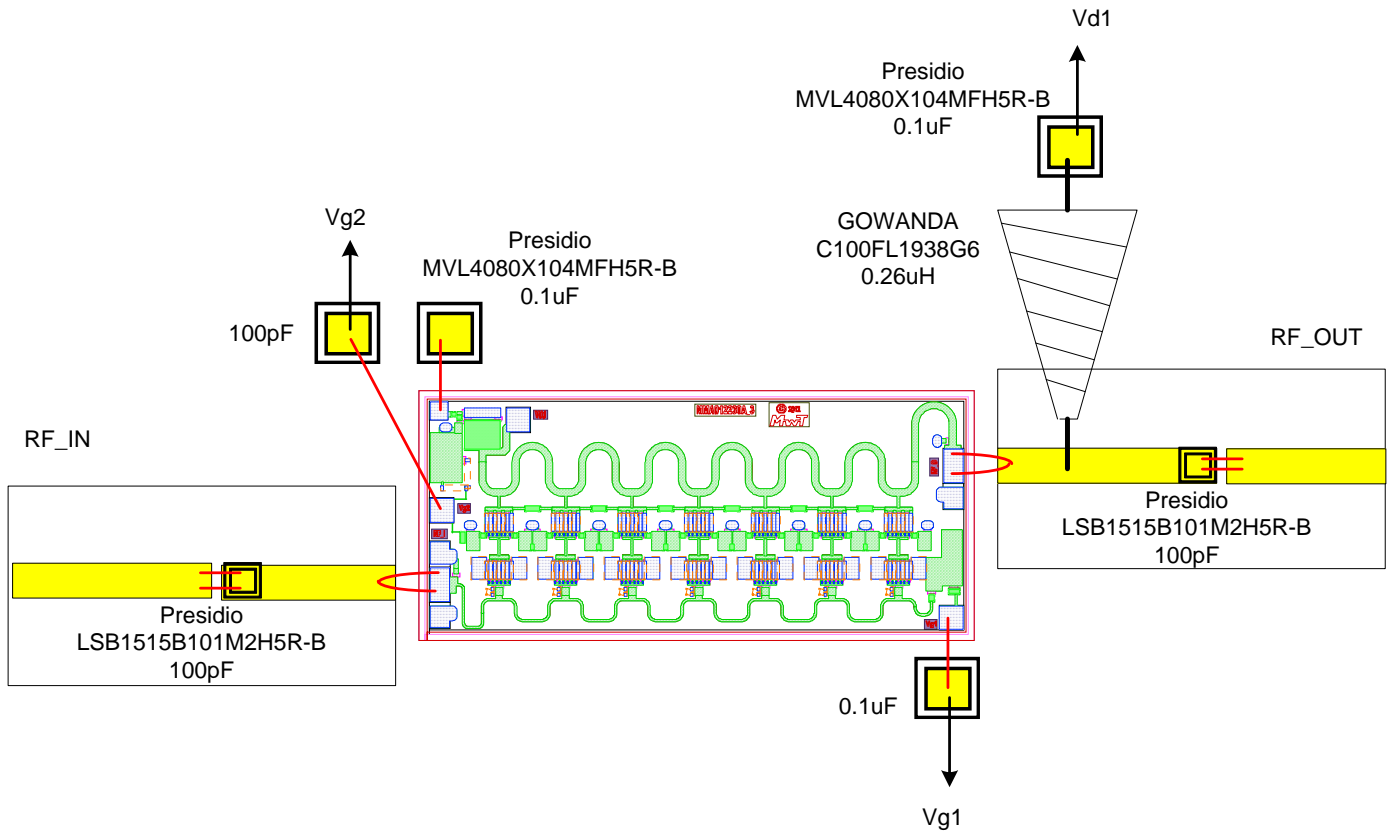

Assembly Diagram

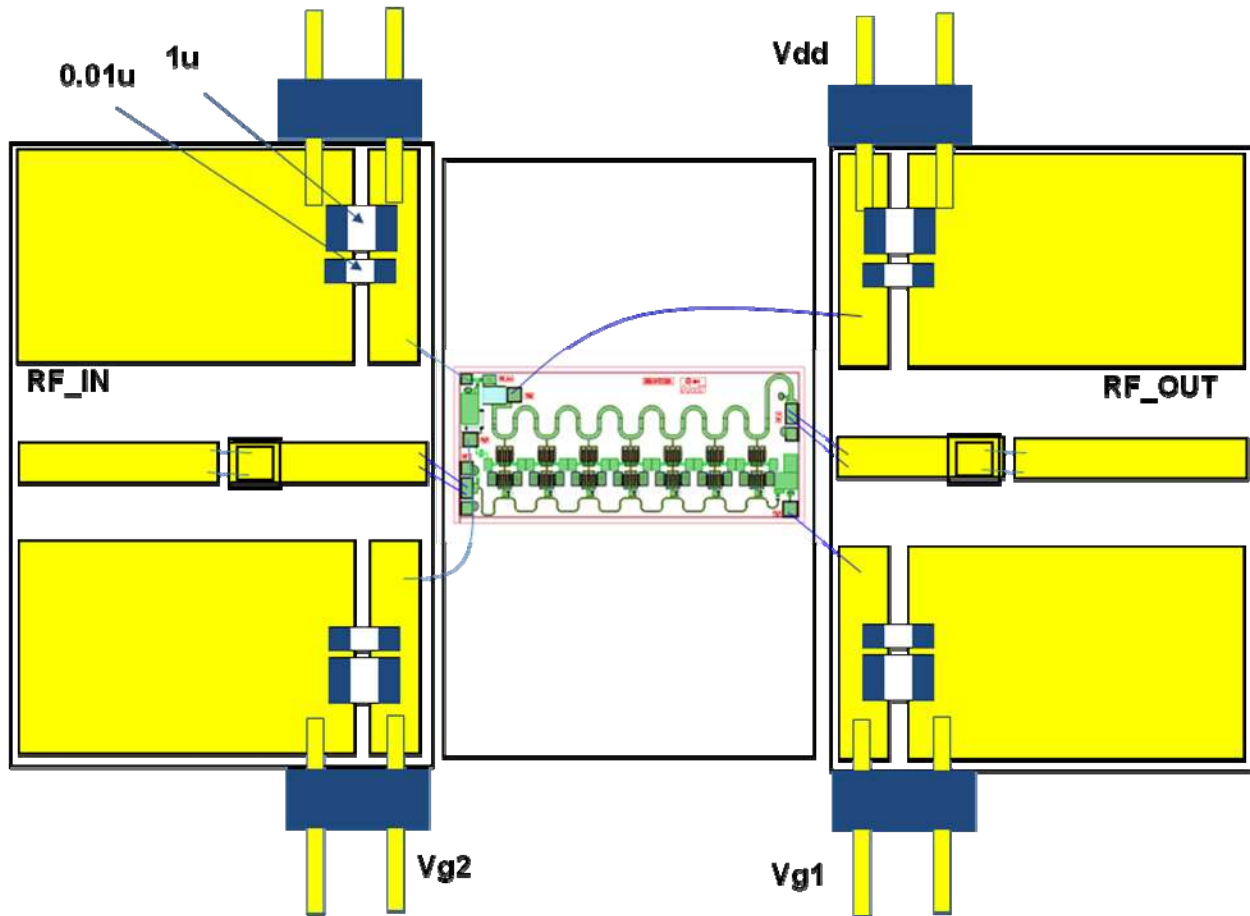

**Demo module DC and RF pin assignment for 2-27GHz applications**