

## Features:

- Frequency Range: 6 – 22 GHz
- P1dB: 18.5 dBm @Vds=5V
- Psat: 19.5 dBm @
- Gain: 14 dB
- Vdd =3 to 6 V
- Ids = 130 mA
- Input and Output Fully Matched to 50 Ω

## Applications:

- Communication systems
- Microwave instrumentations
- ECM

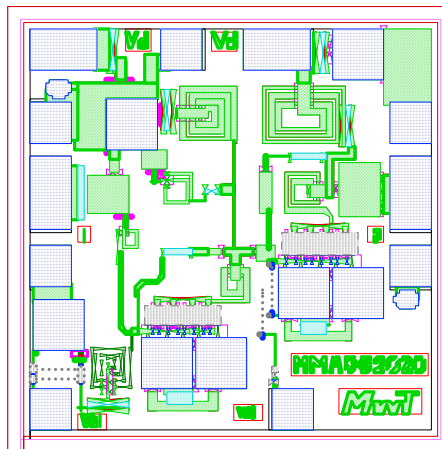

Die size: 920x920x50 um

## Description:

The MMA-062020 is a broadband GaAs MMIC general purpose gain block for 20dBm saturated maximum output power and high gain over full 6 to 22GHz frequency range. This amplifier was optimally designed for broadband applications requiring flat gain with excellent input and output port matches.

## Absolute Maximum Ratings: *(Ta= 25 °C)\**

SYMBOL	PARAMETERS	UNITS	Min.	Max.
Vd1, Vd2	Drain-Supply Voltage	V		6.5
Vg1	Optional Gate supply Voltage	V	-5	1
Vg2	Optional Gate supply Voltage	V	-10	1
Id1	Drain Supply Current	mA		70
Id2	Drain Supply Current	mA		84
Pin max	RF Input Power	dBm		20
Tch	Channel Temperature	°C		+150
Tstg	Storage Temperature	°C		-55 to +165
Tmax	Max. Assembly Temp (60 sec max)	°C		+300

\*Operation of this device above any one of these parameters may cause permanent damage.

**Electrical Specifications:** *V<sub>ds</sub>=5V, I<sub>ds</sub>=130mA, T<sub>a</sub>=25 °C Z<sub>0</sub>=50 ohm*

Parameter	Units	Typical Data
Frequency Range	GHz	6 - 22
Gain (Typ / Min)	dB	14 / 13.5
Gain Flatness (Typ / Max)	+/- dB	0.8 / 1
Input RL(Typ/ Max)	dB	8/7
Output RL(Typ/ Max)	dB	10/8
Output P1dB(Typ/ Min)	dBm	18.3/18
Output IP3 <sup>(1)</sup>	dBm	28
Output Psat(Typ/ Min)	dBm	19.5/19
Operating Current at P1 dB (Typ/ Max)	mA	120 / 130
Thermal Resistance	°C /W	60

(1) Output IP3 is measured with two tones at output power of 0 dBm/tone separated by 20 MHz.

**Typical RF Performance:**  $V_{ds}=5V, I_{ds}=130mA, Z_0=50\text{ ohm}, T_a=25^\circ\text{C}$

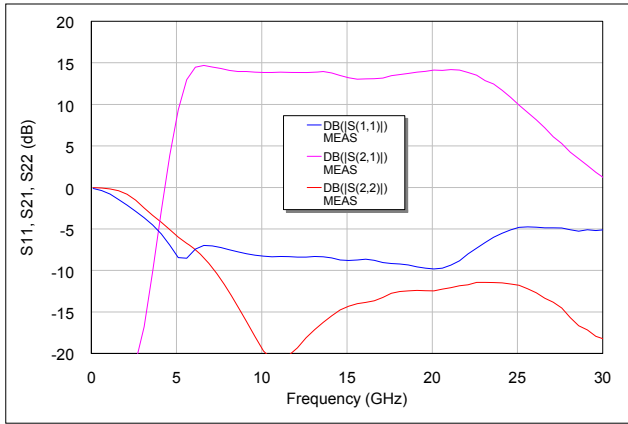

S11[dB], S21[dB], and S22[dB] vs. Frequency

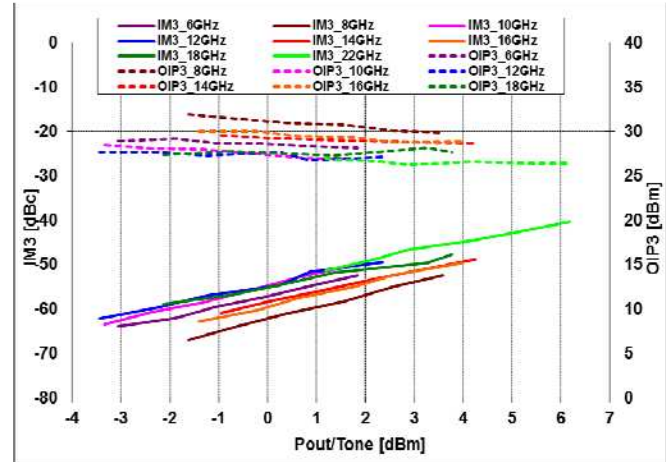

IM3 level [dBc] vs. Output power/tone [dBm]

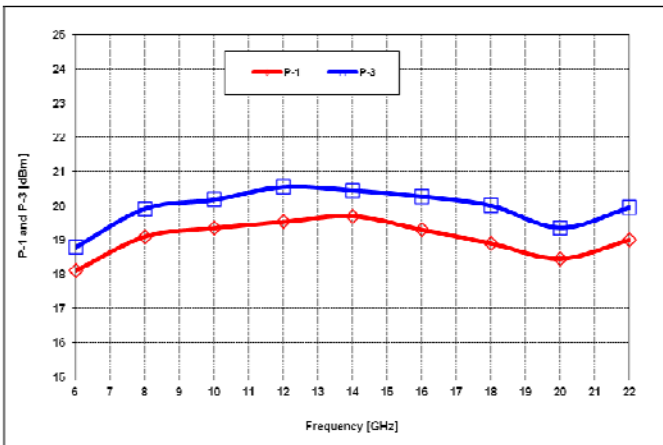

P-1 and Psat vs. Frequency

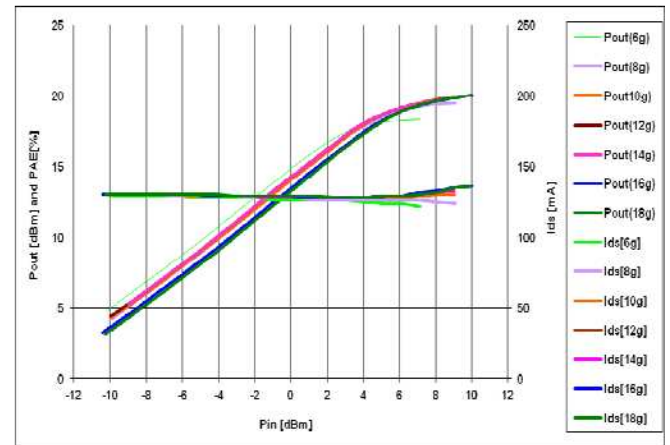

Pout[dBm], Gain[dB], and Ids[mA] vs. Input power [dBm]

**Typical Bias dependent RF Performance:**

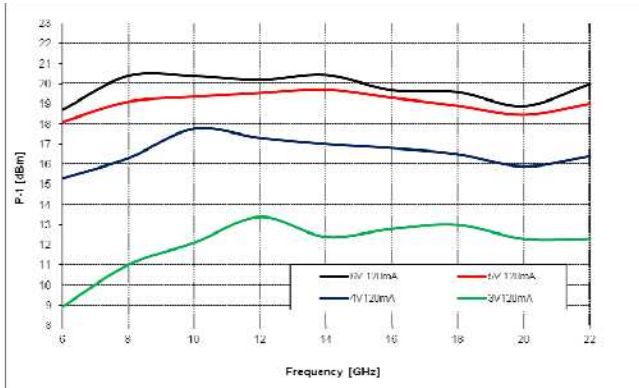

Bias dependent P1 vs. Frequency

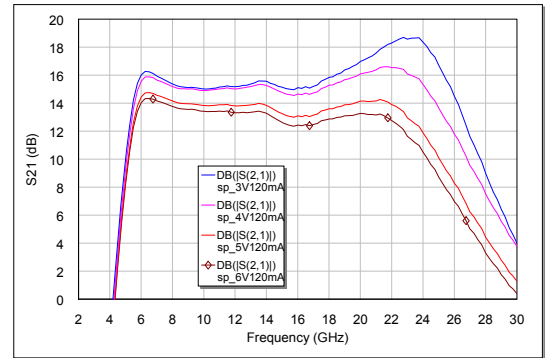

S21(dB) over voltage

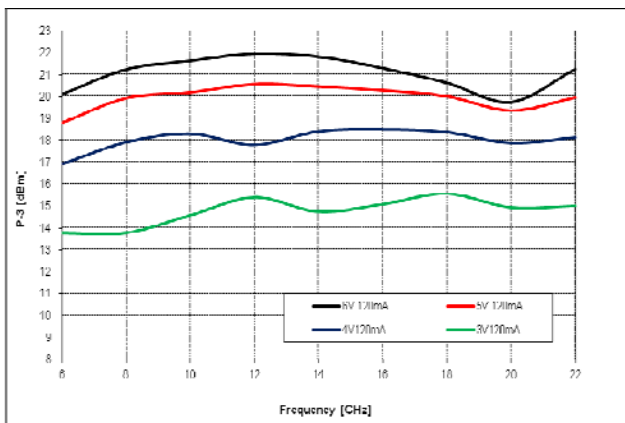

Bias dependent P-3 vs. Frequency

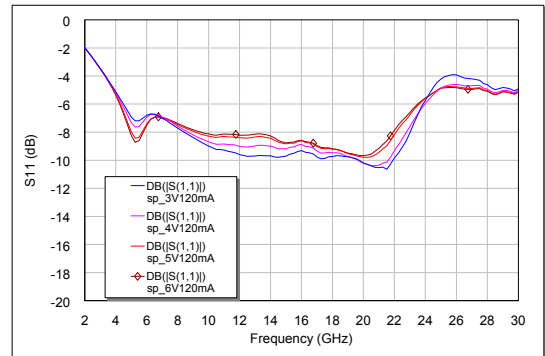

S11(dB) over Voltage

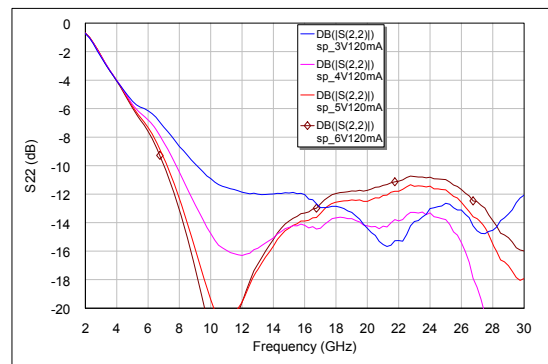

S22(dB) over Voltage

**Typical Over Temperature RF Performance:**  $V_{ds}=5V, I_{ds}=130mA, Z_0=50\text{ ohm}, T_a=25\text{ }^\circ\text{C}$

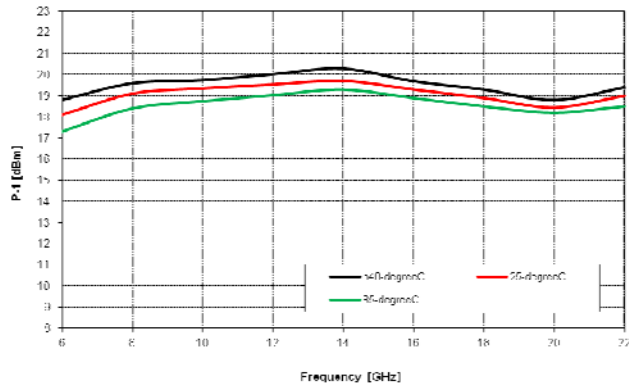

P1 over temperature

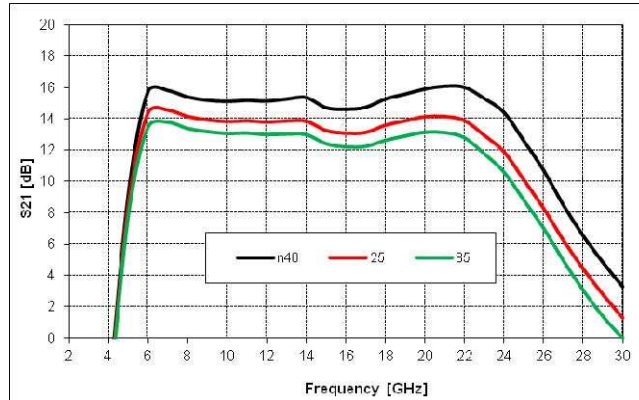

S21(dB) over temperature

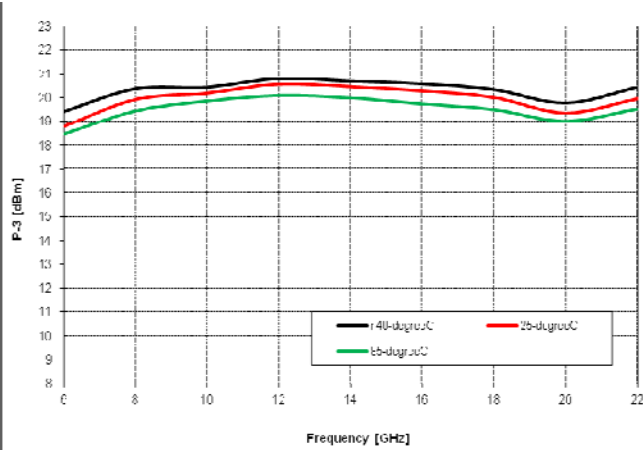

P-3 over temperature

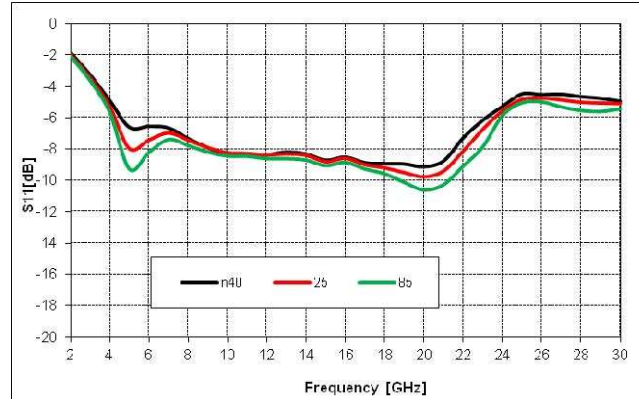

S11(dB) over temperature

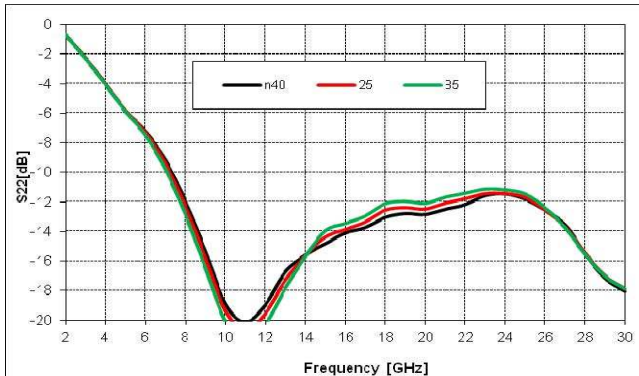

S22(dB) over Voltage

## Applications

The **MMA062020** is a GaAs PHEMT amplifier designed for Class-A condition, flat gain performance from 6GHz to 22GHz. It is applicable for cascadable gain stage for EW amplifiers, buffer stages, LO drivers, and transmitter amplifiers used in commercial communication systems. This amplifier is provided as a bare die format in a Gel-pak.

## Biassing and Operation

The **MMA062020** is normally biased with a single positive supply voltage connected to both Vd1 and Vd2 pins. The recommended drain supply voltages are 3 to 6 volts. RF input and output ports are DC decoupled internally. Typical DC supply connection with bi-passing capacitors for the **MMA062020** is shown in following pages.

Optional gate pads (Vg1 and Vg2) are also provided to allow adjustments in gain, RF output power, and DC power dissipation, if necessary. No connection to the gate pads is needed for single drain-bias operation. However, for custom applications, the DC current flowing through the input and/or output gain stage may be adjusted by applying a voltage to the gate bias pad(s) as shown in Figure 5. A negative gate-pad voltage will decrease the drain current. The gate-pad voltage is approximately zero volts during operation with no DC gate supply. Refer to the absolute maximum rating table for allowing DC and thermal conditions.

## Assembly Techniques

GaAs MMICs are ESD sensitive. ESD preventive measures must be employed in all aspects of storage, handling, and assembly. MMIC ESD precautions, handling considerations, die attach and bonding methods are critical factors in successful GaAs MMIC performance and reliability.

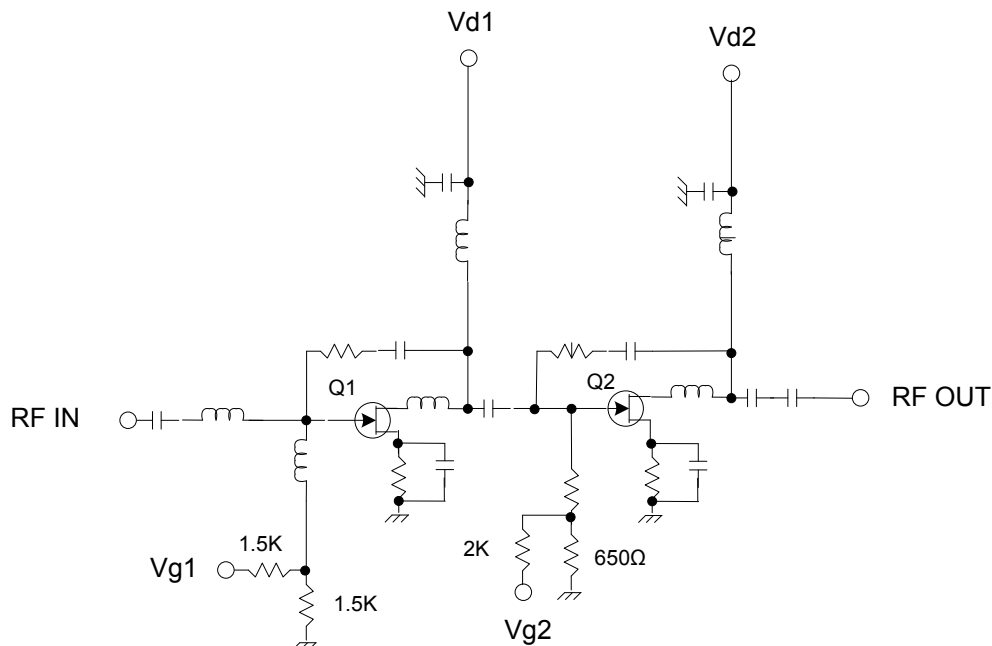
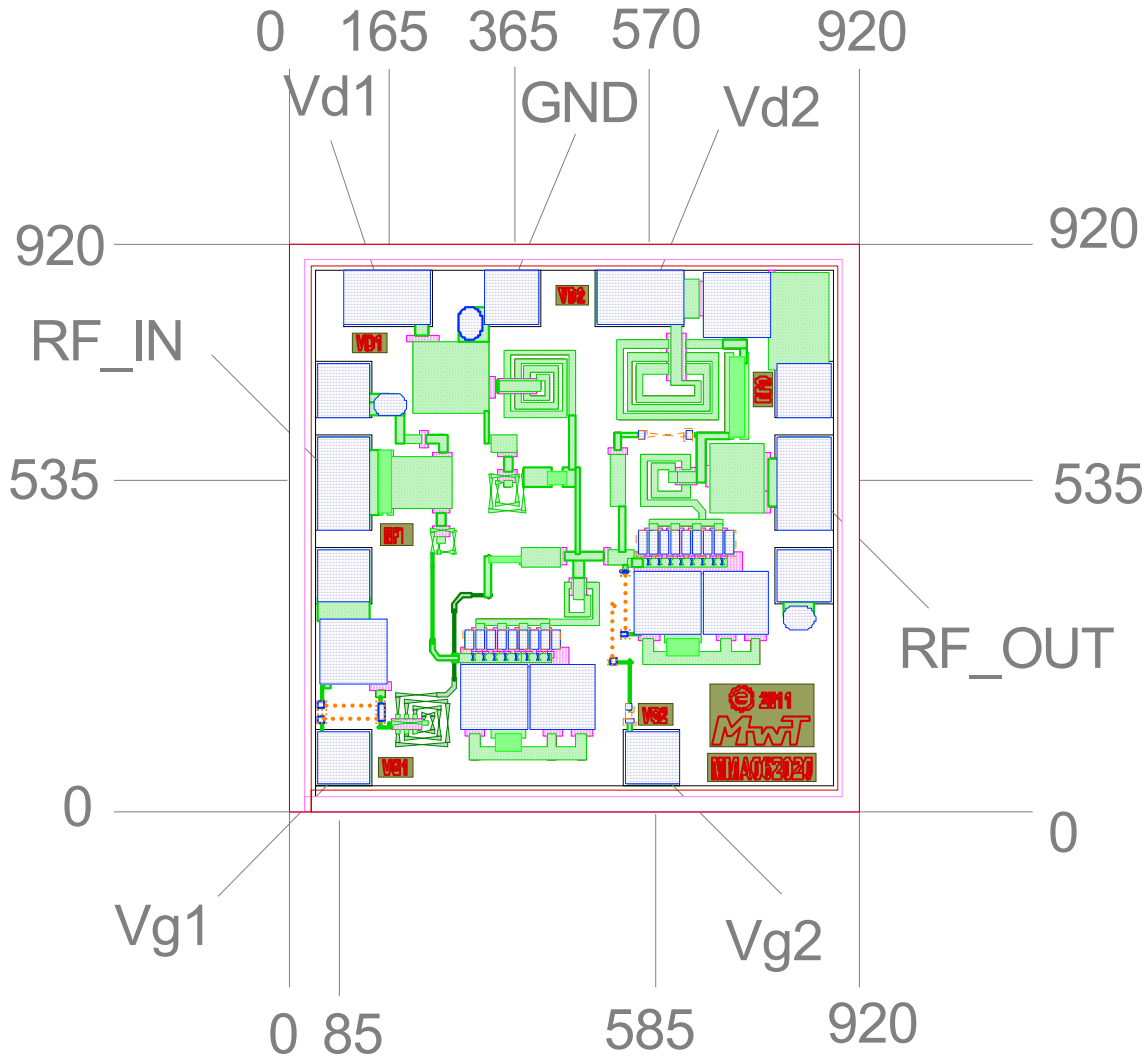

Figure 1 MMA062020 Simplified schematic

**Mechanical Information:** *Top view*



Units are in um.

Figure 2. Die outline and bonding pad locations

**Application Circuit:**

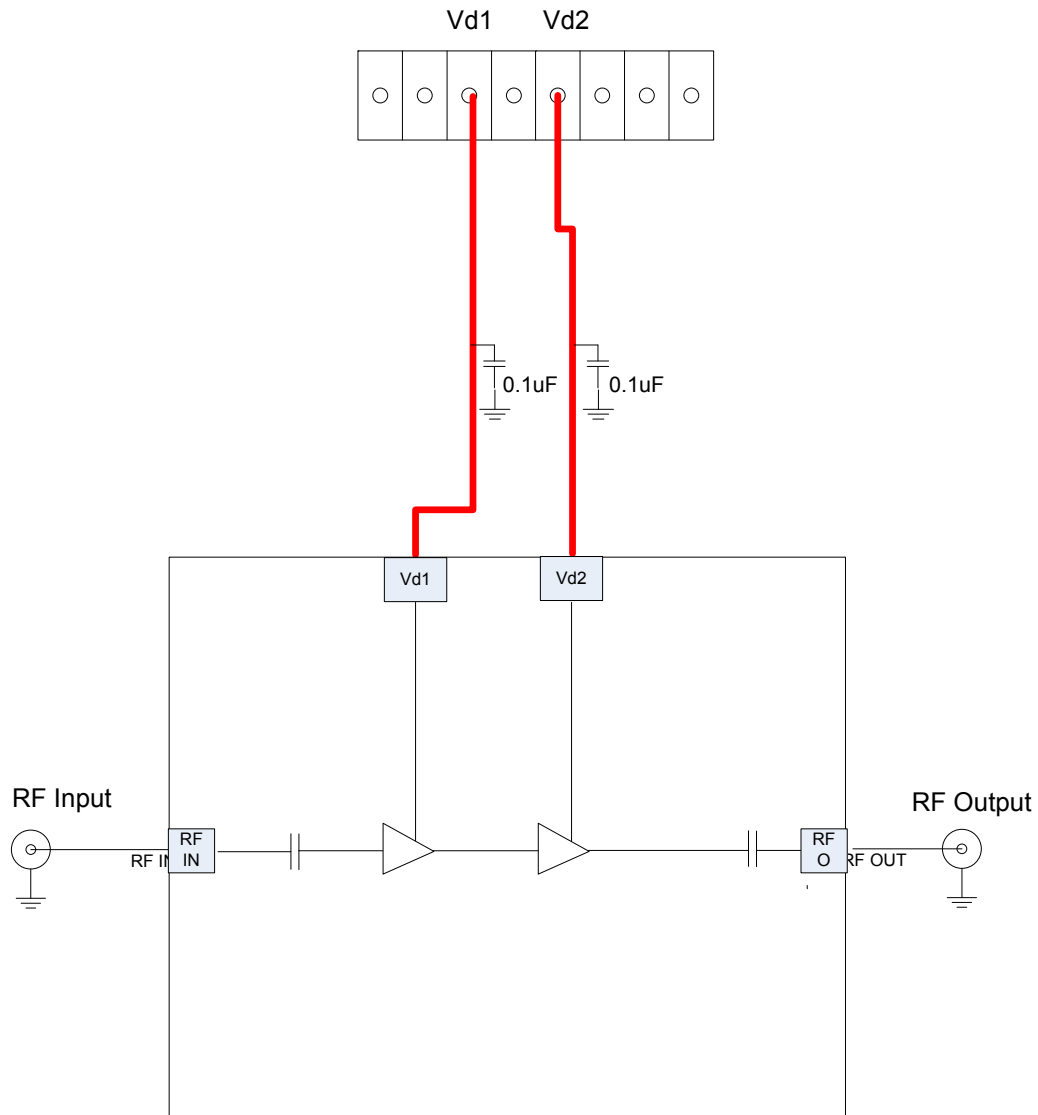

Figure 3 Application for single drain-bias operation

**Recommended Assembly:**

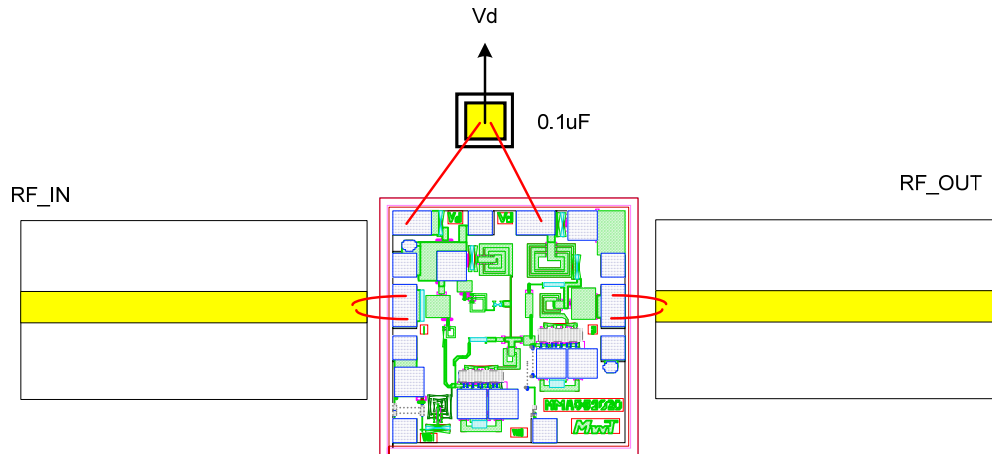

Figure 4 Assembly for single drain-bias operation

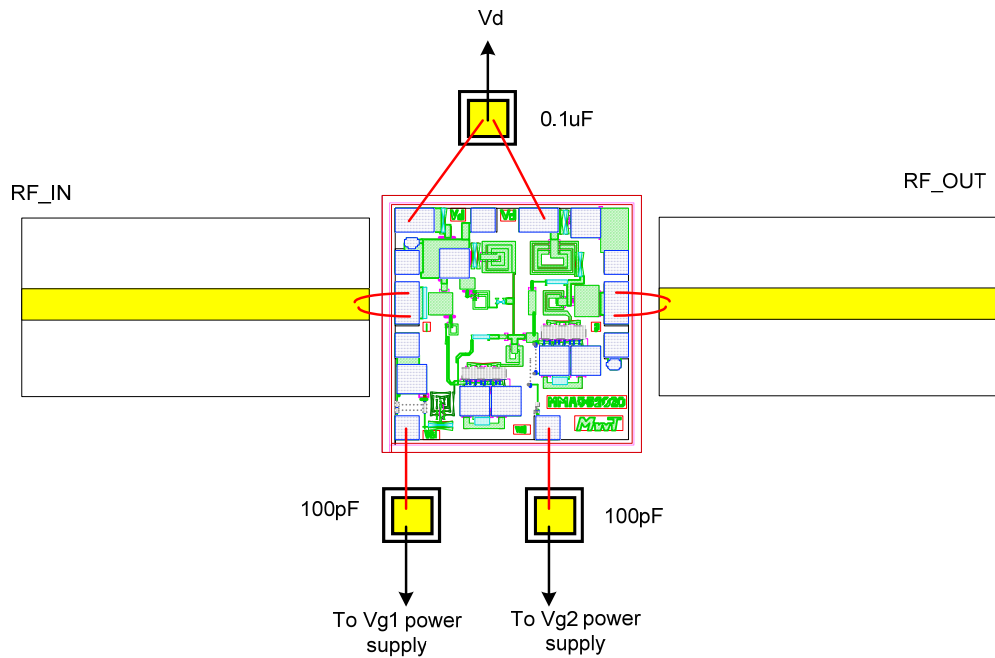

Figure 5 Assembly with gate bias connection