

# SERPAC WM093C (3D exploded)

Electronic Enclosures

- Click on image to show toolbar. Use  to Play/Pause Animation\*.
- Left click and drag on image to move 3D model.

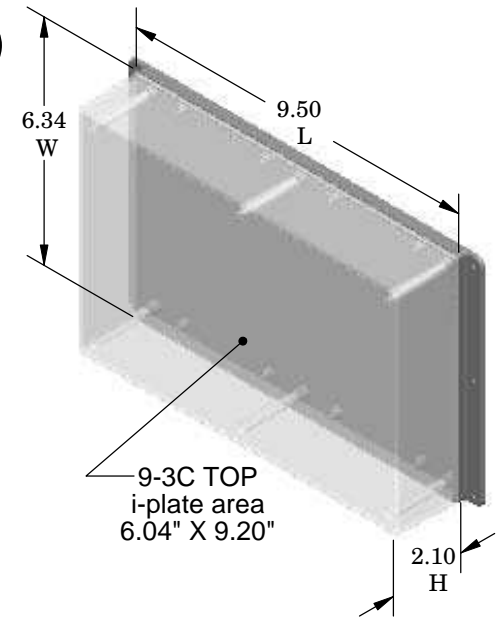
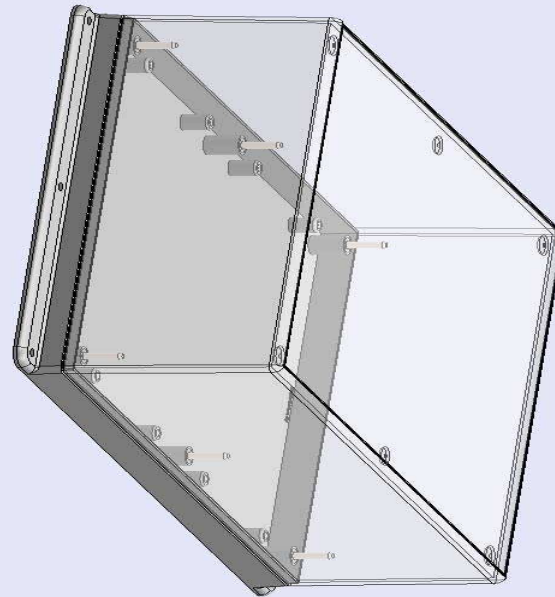

**Waterproofing gasket  
PS19 optional  
see note #2**

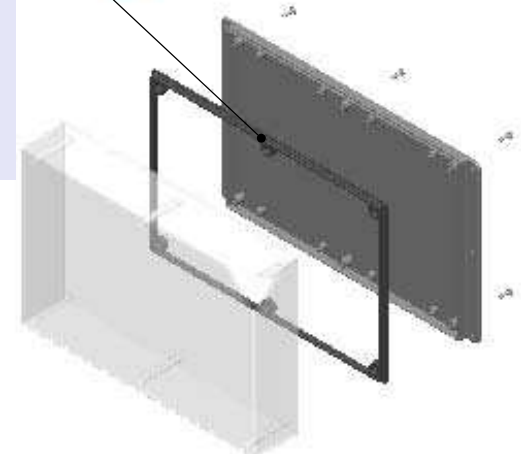

- a) zoom in & out with center wheel.
  - b) Pause at any moment to view and or print views.
  - c) Change the views to ortho and section views if needed from the Views pull down menu.
  - d) Explore options included in the tool bar like: Views, Transparency of model, Lighting type, etc.
- \*(To have full interaction with the animated PDF files, please use free Adobe Reader 9 or newer version.)

PART NO.	DESCRIPTION (Included)	ACCESSORIES (Optional) More available; see website	
9-3C	TOP	PART NO.	DESCRIPTION
WM09	BOTTOM	50	Non-skid Feet
6005	#4 self tapping screw (6)	PS19	Perimeter Seal
		6004	Circuit board #4 screws

- Notes: Enclosure weight .78 lbs/ 354 gm
- 1) Enclosure meets or exceeds IP40 and NEMA 1
  - 2) When used with PS19 the enclosure meets or exceeds IP 67 and NEMA 4X, 12 and 13 MIL-STD-810G 506.5
  - 3) Circuit Board drawings can be downloaded at:  
<http://www.serpac.com/Products/Series/x9x/drawings/19X-CB.pdf>
  - 4) All components are RoHS compliant.

**ALL DIMENSIONS ARE ±.010" 5/17/10 (1 of 2)**  
 2009 Wright Ave. La Verne, CA 91750  
 Ph. (626) 331-0517 Ex. (626) 331-8584 [serpac.com](http://serpac.com)

# SERPAC WM093C (user print)

Electronic Enclosures

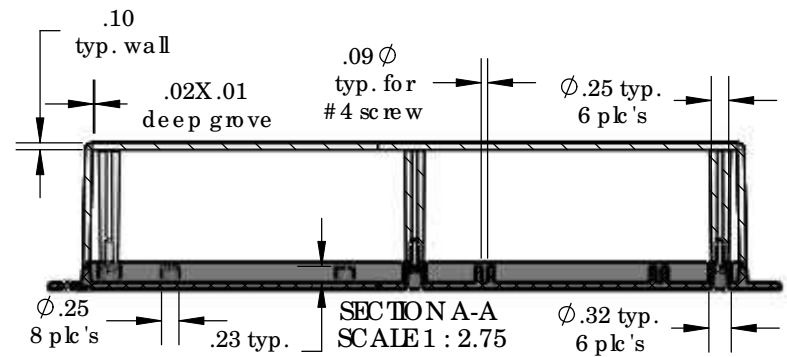
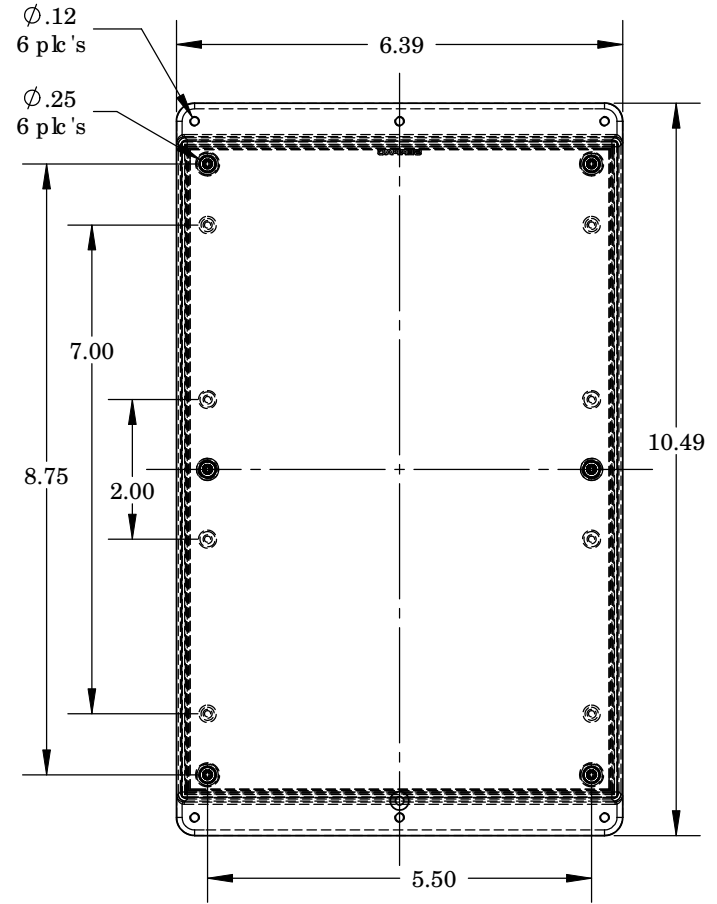
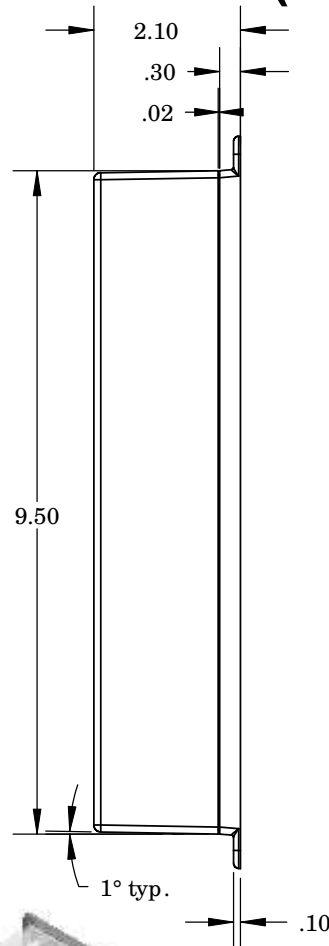
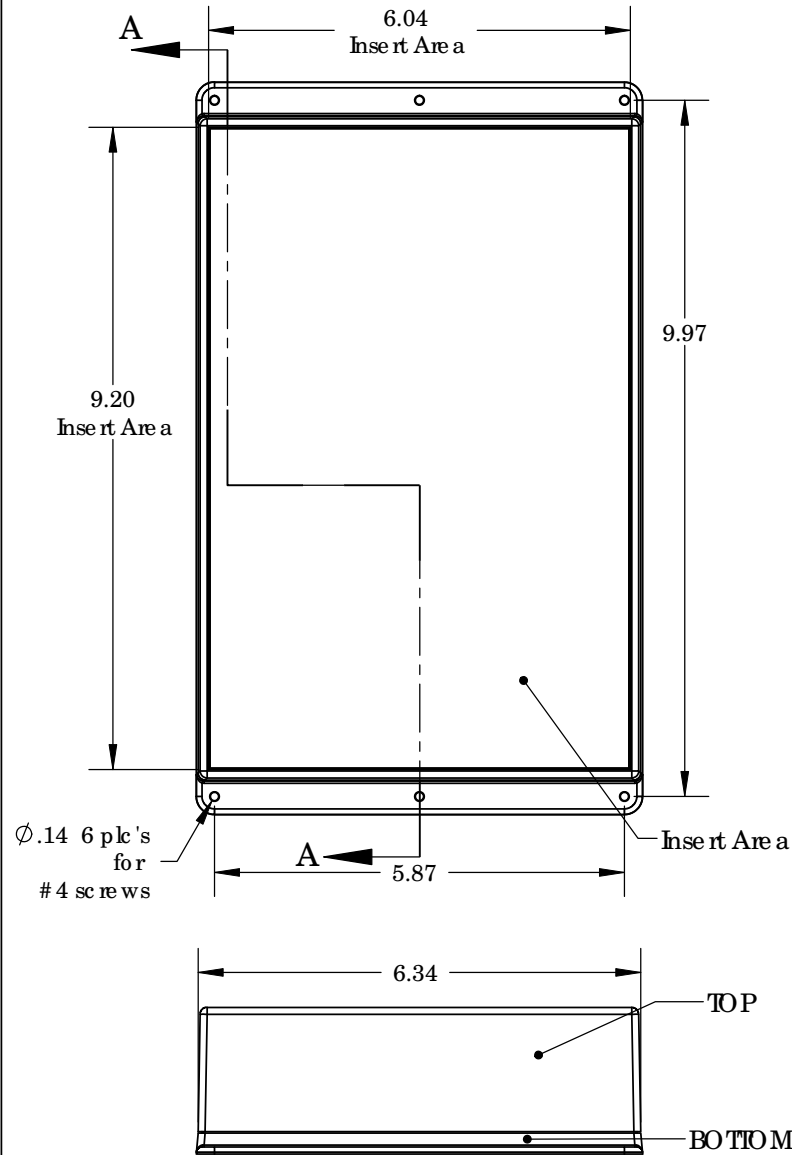

PART NO.	DESCRIPTION (Included)	ACCESSORIES (Optional) More available; see website	
		PART NO.	DESCRIPTION
9-3C	TOP		
WM09	BOTTOM	50	Non-skid Feet
6005	#4 self tapping screw (6)	PS19	Perimeter Seal
		6004	Circuit board #4 screw

- Notes: Enclosure weight .78 lbs / 354 gm
- 1) Enclosure meets or exceeds IP40 and NEMA 1
  - 2) When used with PS19 the enclosure meets or exceeds IP67 and NEMA 4X, 12 and 13 MIL-STD-810G 506.5
  - 3) Circuit Board drawings can be downloaded at:  
<http://www.serpac.com/Products/Series/x9x/drawings/19X-CB.pdf>
  - 4) All components are RoHS Compliant.

ALL DIMENSIONS ARE  $\pm .010"$  5/17/10 (2 of 2)  
2009 Wright Ave. La Verne, CA 91750  
Ph. (626) 331-0517 Ex. (626) 331-8584 [www.serpac.com](http://www.serpac.com)