

WM072-RI (exploded isometric)

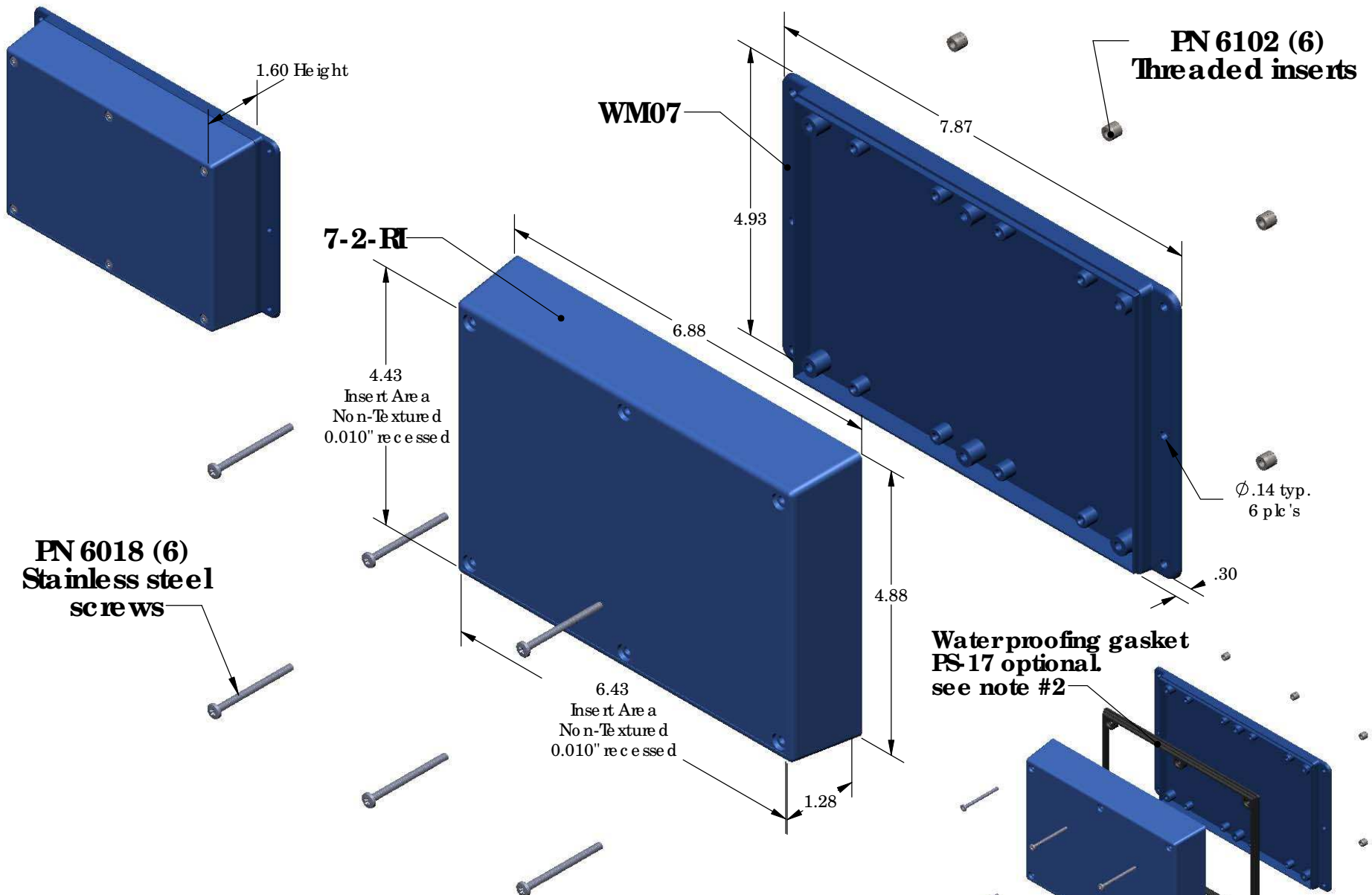

PART NO.	DESCRIPTION (Included)	ACCESSORIES (Optional)	
		PART NO.	DESCRIPTION
7-2-RI	TOP		
WM07	BOTTOM	50	Non-skid Feet
6018	4-40 SCREW (6)	PS-17	Perimeter Seal
6102	THREADED INSERTS (6)		

- Notes:
- 1) Enclosure meets or exceeds IP40 and NEMA 1
 - 2) When used with PS-17 the enclosure meets or exceeds IP 67 and NEMA 4X, 12 and 13 MIL-SID-810G 506.5
 - 3) Circuit Board drawings can be downloaded at:
<http://www.serpac.com/Accessories/CircuitBoard/drawings/370-470.pdf>
 - 4) All components are RoHS Compliant.

SERPAC WM072-RI (user print)

Electronic Enclosures

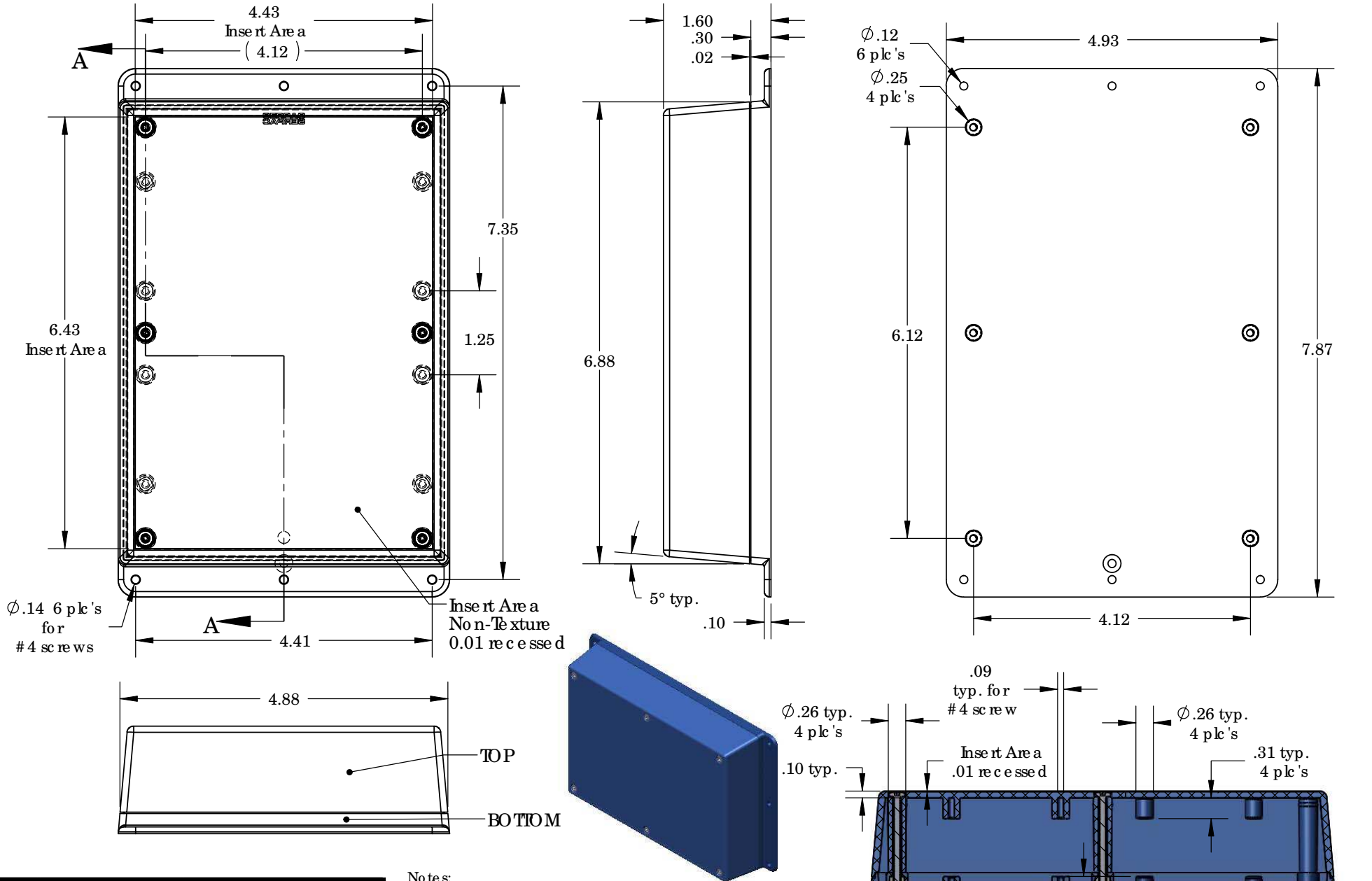

PART NO.	DESCRIPTION (Included)	ACCESSORIES (Optional)	
7-2-RI	TOP	PART NO.	DESCRIPTION
WM07	BOTTOM	50	Non-skid Feet
6018	4-40 SCREW (6)	PS-17	Perimeter Seal
6102	THREADED INSERTS (6)		

Notes:

- 1) Enclosure meets or exceeds IP40 and NEMA 1
- 2) When used with PS-17 the enclosure meets or exceeds IP 67 and NEMA 4X, 12 and 13 MIL-STD-810G 506.5
- 3) Circuit Board drawings can be downloaded at:
<http://www.serpac.com/Accessories/CircuitBoard/drawings/370-470.pdf>
- 4) All components are RoHS Compliant.

ALL DIMENSIONS ARE $\pm .010"$ 6/04/09 (2 of 2)
 619 Commercial Ave. Covina, CA 91723
 Ph. (626) 331-0517 Ex. (626) 331-8584 www.serpac.com