

# SERPAC WM072C (3D exploded)

Electronic Enclosures

- Click on image to show toolbar. Use ▶ || to Play/Pause Animation\*.
- Left click and drag on image to move 3D model.

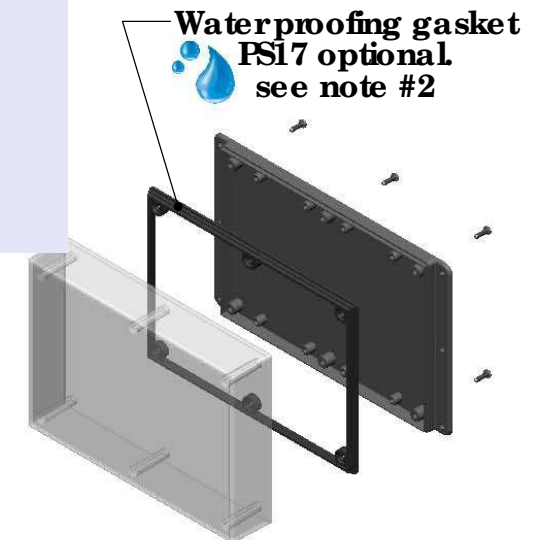
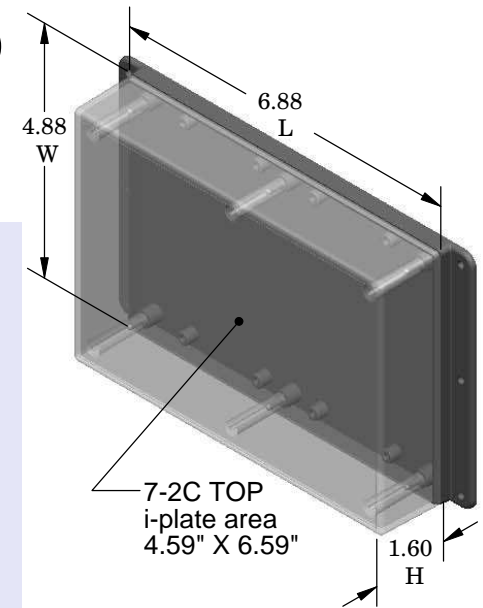
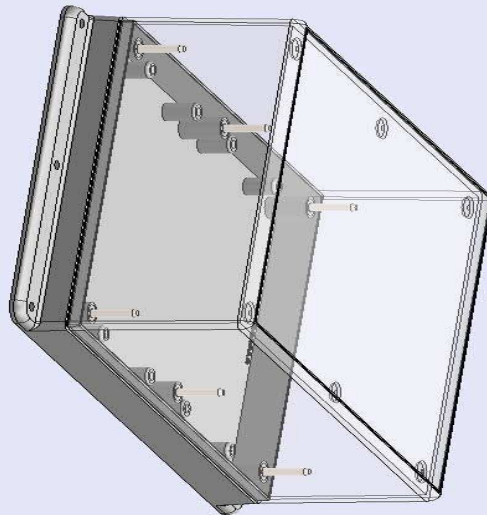

**Waterproofing gasket  
PS17 optional  
see note #2**

- a) Zoom in & out with center wheel.
  - b) Pause at any moment to view and or print views.
  - c) Change the views to ortho and section views if needed from the Views pull down menu.
  - d) Explore options included in the tool bar like: Views, Transparency of model, Lighting type, etc.
- \*(To have full interaction with the animated PDF files, please use free Adobe Reader 9 or newer version.)

PART NO.	DESCRIPTION (Included)	ACCESSORIES (Optional) More available; see website	
7-2C	TOP	PART NO.	DESCRIPTION
WM07	BOTTOM	50	Non-skid Feet
6005	#4 self tapping screw (6)	PS17	Perimeter Seal
		6004	Screw for circuit board

- Notes: Enclosure weight .44 lbs/ 201 gm
- 1) Enclosure meets or exceeds IP40 and NEMA 1
  - 2) When used with PS17 the enclosure meets or exceeds IP 67 and NEMA 4X, 12 and 13 MIL-STD-810G 506.5
  - 3) Circuit Board drawings can be downloaded at:  
<http://www.sempac.com/Accessories/CircuitBoard/drawings/370-470.pdf>
  - 4) All components are RoHS compliant.

**ALL DIMENSIONS ARE ± .010" 5/18/10 (1 of 2)**  
 2009 Wright Ave. La Verne, CA 91750  
 Ph. (626) 331-0517 Ex. (626) 331-8584 [sempac.com](http://sempac.com)

# SERPAC WM072C (user print)

Electronic Enclosures

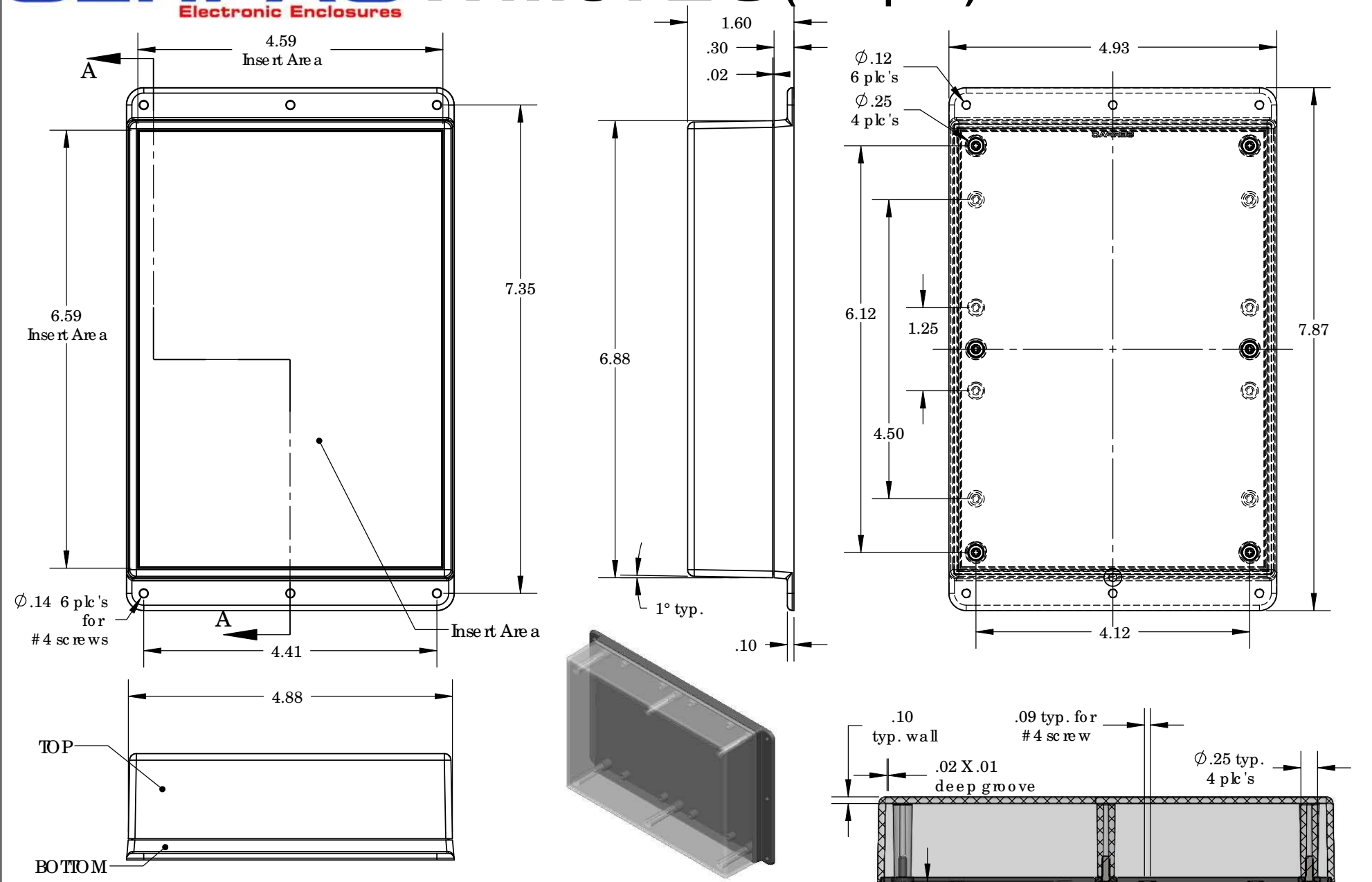

PART NO.	DESCRIPTION (Included)	ACCESSORIES (Optional) More available; see website	
7-2C	TOP	PART NO.	DESCRIPTION
WM07	BOTTOM	50	Non-skid Feet
6005	#4 self tapping screw (6)	PS17	Perimeter Seal
		6004	Screw for circuit board

Notes: Enclosure weight .44 lbs / 201 gm  
 1) Enclosure meets or exceeds IP40 and NEMA 1  
 2) When used with PS17 the enclosure meets or exceeds IP 67 and NEMA 4X, 12 and 13 MIL-STD-810G 506.5  
 3) Circuit Board drawings can be downloaded at:  
<http://www.serpac.com/Accessories/CircuitBoard/drawings/370-470.pdf>  
 4) All components are RoHS Compliant.

SECTION A-A  
 SCALE 1 : 2  
 ALL DIMENSIONS ARE ± .010" 5/18/10 (2 of 2)  
 2009 Wright Ave. La Verne, CA 91750  
 Ph. (626) 331-0517 Ex. (626) 331-8584 www.serpac.com