

SERPAC WM052C (3D exploded)

Electronic Enclosures

- Click on image to show toolbar. Use  to Play/Pause Animation*.
- Left click and drag on image to move 3D model.

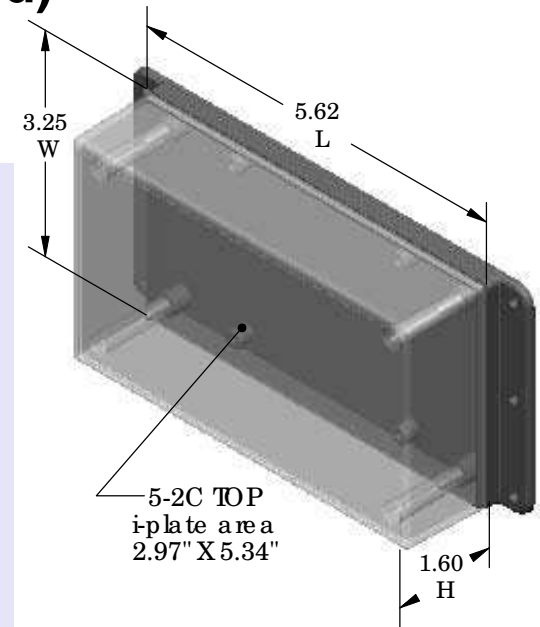
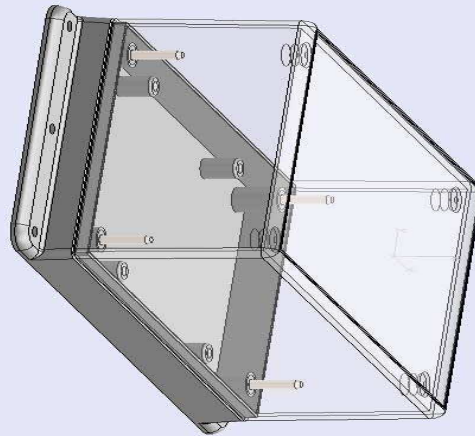

Waterproofing gasket
PS15 optional
see note #2

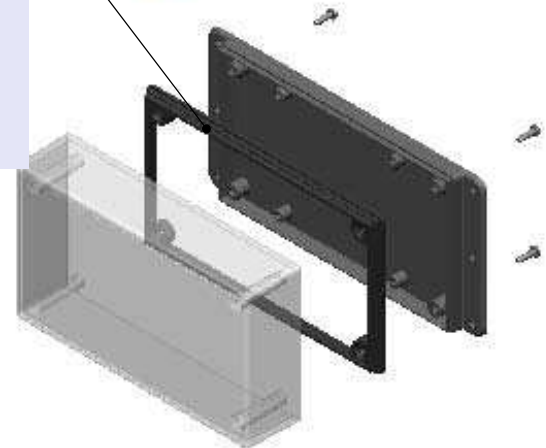

- a) Zoom in & out with center wheel.
 - b) Pause at any moment to view and or print views.
 - c) Change the views to ortho and section views if needed from the Views pull down menu.
 - d) Explore options included in the tool bar like: Views, Transparency of model, Lighting type, etc.
- *(To have full interaction with the animated PDF files, please use free Adobe Reader 9 or newer version.)

PART NO.	DESCRIPTION (Included)	ACCESSORIES (Optional) More available; see website	
5-2C	TOP	PART NO.	DESCRIPTION
WM05	BOTTOM	50	Non-skid Feet
6005	#4 self tapping screw (4)	PS15	Perimeter Seal
		350	Prototype grid board
		450	Prototype clad board

- Notes: Enclosure weight .27 lbs/ 124 gm
- 1) Enclosure meets or exceeds IP40 and NEMA 1
 - 2) When used with PS15 the enclosure meets or exceeds IP 67 and NEMA 4X, 12 and 13 MIL-STD-810G 506.5
 - 3) Circuit Board drawings can be downloaded at:
<http://www.serpac.com/Accessories/CircuitBoard/drawings/350-450-cbg.pdf>
 - 4) All components are RoHS Compliant.

ALL DIMENSIONS ARE ±.010" 5/20/10 (1 of 2)
2009 Wright Ave. La Verne, CA 91750

Ph. (626) 331-0517 Ex. (626) 331-8584 www.serpac.com

SERPAC WM052C (user print)

Electronic Enclosures

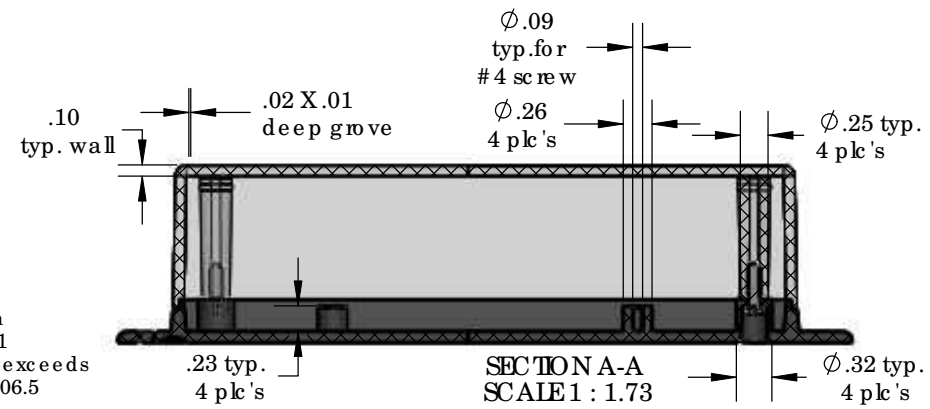
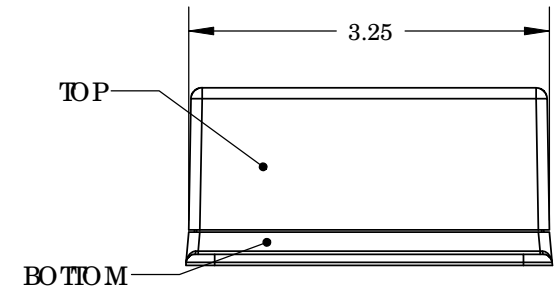
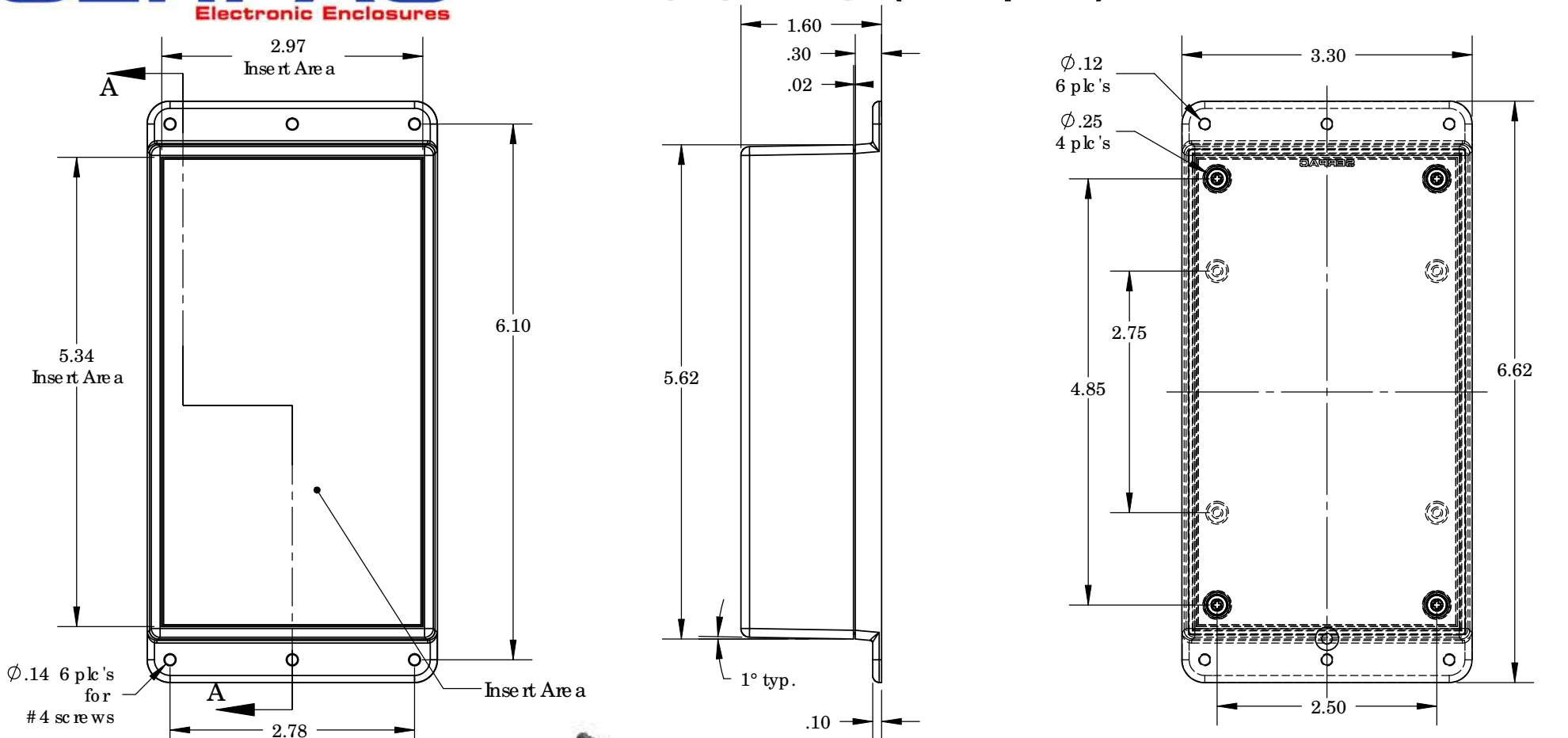

PART NO.	DESCRIPTION (Included)	ACCESSORIES (Optional) More available; see website	
		PART NO.	DESCRIPTION
5-2C	TOP	50	Non-skid Feet
WM05	BOTTOM	350	Prototype grid board
6005	#4 self tapping screw (4)	450	Prototype clad board

Notes:
 Enclosure weight .27 lbs / 124 gm
 1) Enclosure meets or exceeds IP40 and NEMA 1
 2) When used with PS15 the enclosure meets or exceeds IP67 and NEMA 4X, 12 and 13 MIL-SID-810G 506.5
 3) Circuit Board drawings can be download at:
http://www.serpac.com/Products/Serials/x53/drawings/X53_top-CB.pdf
 4) All components are RoHS Compliant.

SECTION A-A
 SCALE 1 : 1.73

ALL DIMENSIONS ARE ± .010" 5/20/10 (2 of 2)
 2009 Wright Ave. La Verne, CA 91750
 Ph. (626) 331-0517 Ex. (626) 331-8584 www.serpac.com