

# WM031-RI (exploded isometric)

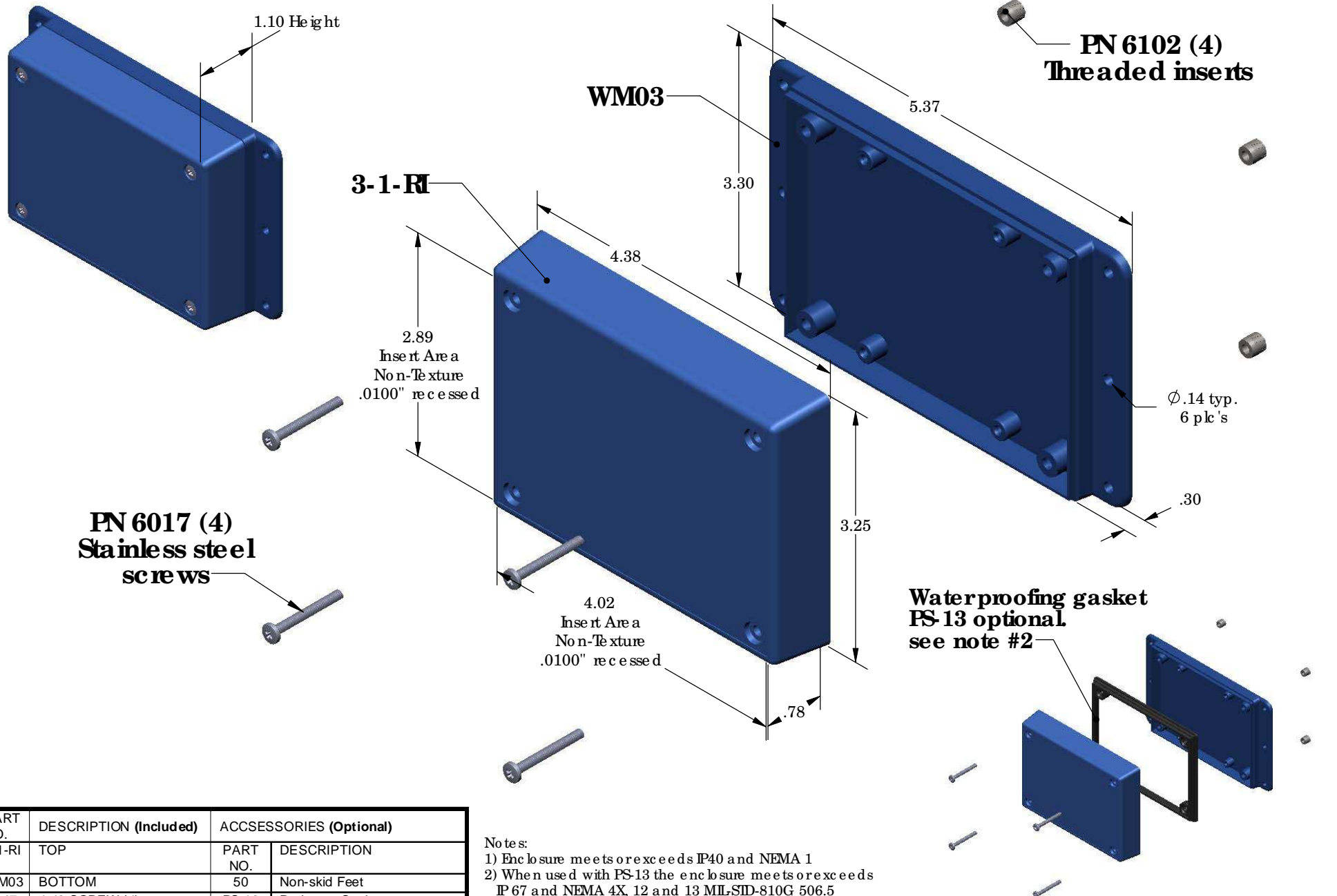

| PART NO. | DESCRIPTION (Included) | ACCESSORIES (Optional) |                              |
|----------|------------------------|------------------------|------------------------------|
|          |                        | PART NO.               | DESCRIPTION                  |
| 3-1-RI   | TOP                    |                        |                              |
| WM03     | BOTTOM                 | 50                     | Non-skid Feet                |
| 6017     | 4-40 SCREW (4)         | PS-13                  | Perimeter Seal               |
| 6102     | THREADED INSERTS (4)   | 330                    | Prototype grid board (Horiz) |
|          |                        | 430                    | Prototype clad board (Horiz) |

Notes:

- 1) Enclosure meets or exceeds IP40 and NEMA 1
- 2) When used with PS-13 the enclosure meets or exceeds IP 67 and NEMA 4X, 12 and 13 MIL-STD-810G 506.5
- 3) Circuit Board drawings can be downloaded at: <http://www.serpac.com/Accessories/CircuitBoard/drawings/330-430-cbg.pdf>
- 4) All components are RoHS Compliant.

ALL DIMENSIONS ARE ± .010" 5/29/09 (1 of 2)  
 619 Commercial Ave. Covina, CA 91723  
 Ph. (626) 331-0517 Ex. (626) 331-8584 serpac.com

